

DATA SHEET EPM 1000

Installation dimensions

CPU and automatic floor management

Landing levels call system

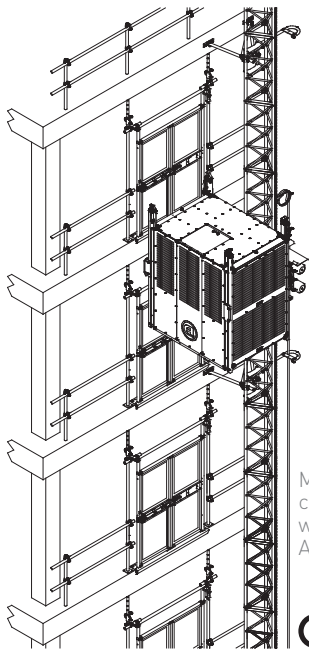

Mast compatible with other Alba hoists

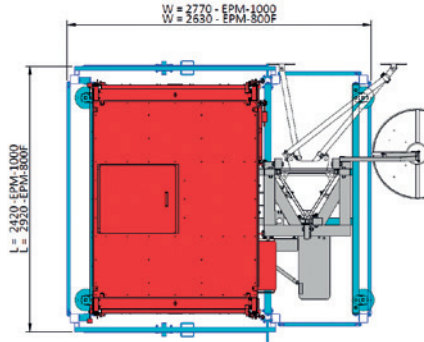

Overspeed parachute with auto-recovery system



Auxiliar catwalk for anchorage assembly



SAFETY DEVICES INCLUDED AND OPTIONS

INCLUDED OPTION

GENERALS

Gearmotors with electromechanical brake	✓
Overspeed parachute, with auto-recovery system	✓
Emergency lowering lever	✓
Cage doors with mechanical / electrical interlock	✓
Landing doors with mechanical / electrical interlock	✓
Base enclosure according to EN-12159	✓
Hoist control display with signaling LEDs:	✓
- Cage door open	
- Landing door open	
- End of mast	
- Upper/lower endtrack	
- Aux. Crane interfering	
- Last 2 m Zone	
- Overspeed parachute	
- Cage overload	
- Motor overheat fault	
- Hoist free / busy	
Automatic floor management	✓
Buffers at the ground base	✓
Hoist control CPU, with event log	✓
Upper/lower endtrack limit switch	✓
Safety endtrack limit switches	✓
Overload detection device	✓
Mast presence switch	✓
Last mast without rack	✓
Aux. catwalk for anchorage assembly	✓
Aux. crane for mast assembly	✓
Motors with brake wear signal	✓
Cage floor of non-slipping galvanized steel	✓
Movement warning horn	✓
Phase control	✓
Emergency stop	✓
Emergency exit, accessible roof with safety railing	✓
Landing levels call system	✓
Parachute test remote control and mast assembly	✓
Operator aux. external cage	✓
Automatic greaser	✓

TECHNICAL FEATURES

	EPM 1000	EPM 1000V	EPM 800F	EPM 800FV
Motor control	DIRECT	FREQ. CONVERTER	DIRECT	FREQ. CONVERTER
Vertical speed	20 m/min	33 m/min	20 m/min	33 m/min
Maximum capacity	1.000 kg 12 pax.		800 kg 10 pax.	
Cage dimensions (LxWxH)	2.000 x 1.400 x 2.100 mm		2.500 x 1.400 x 2.100 mm	
Maximum height (*)	120 m (*)			
Anchorage each (max.)	6 m			
Height over last anchorage	1,5 m			
First anchorage height	6 m			
Loading height-to-ground	400 mm			
Maximum load (assembly)	300 kg			
Noise emission value	<70 dB			
Regulations reference	EN-12159 ; 2006/42/CE			

ELECTRICAL DATA

	EPM 1000 EPM 800F	EPM 1000V EPM 800FV
Motor power	2 x 3 kW (50Hz) 2 x 3,6 kW (60Hz)	
Input power connection	400 V - 50Hz 440 V - 60Hz	380 ÷ 460 V - 50/60Hz
Power consumption	7 kW	15 kW
Nominal current	15 A	30 A
Supply power	20 kVA	30 kVA
Overload protection	4 x 25 A	4 x 40 A
Differential protection Calibration Sensitivity	25 A 300 mA	40 A 300 mA
Control voltage	48 V	
Auxiliar handtools socket	230 V - 50/60 Hz 1200 W	
Cable section	4 x 6 mm ²	

MAST SECTION



Triangle mast
Length: 1,5 m
Weight: 47 kg

Mast compatibility: (see p.50)
Mast climber: PEC 120
Material hoist: MC 1000
Transport platform: PT 1200

(*) For greater heights, ask to manufacturer.