

REBAR SCISSORS

HIGH QUALITY STEEL CUTTERS

Very resistant scissors with interchangeable 3 edge blades. They are made of forged steel and are suitable for cutting steel rods up to 16mm in diameter.



Screwing system that makes easier the changing of the cutting edge.

- The jaws and hinge-hooks are made of hot stamped, quality with thermal treatment.
- Steel cutting blades, interchangeable with triangular cross-section, thus allowing the use of its three cutting edges without needing to replace the jaws. The economy is evident.
- For cutting steels with a tensile strength between 1250 N/mm² and 1500 N/mm² (spring wire, piano wire, prestressed rod, etc.), the special High Resistance blades should be used.
- Substantial handles, made of weldless cold-drawn steel tube, with no risk of bending or breaking the handle.

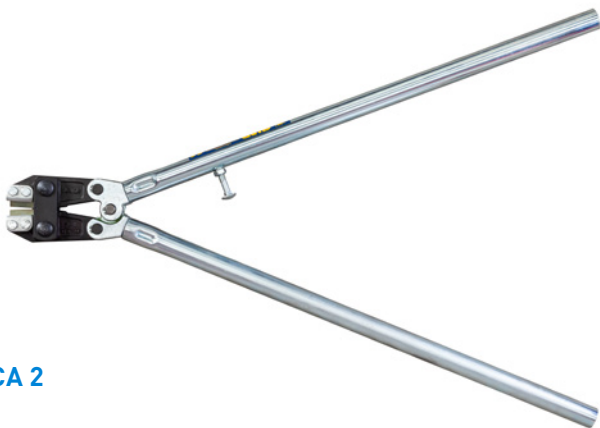

CA 2



CA 3

TECHNICAL FEATURES

CUTTING CAPACITIES	Maximum tensile strength of the material		CA 2 "JUNIOR"	CA 3 "SENIOR"
With standard blades	Nm ² : 850 P.S.I.: 120.000	Ø mm Ø inches	14 9/16"	16 5/8"
With high duty blades	Nm ² : 1250 P.S.I.: 180.000	Ø mm Ø inches	12 15/32"	14 9/16"
	Nm ² : 1250 P.S.I.: 180.000	Ø mm Ø inches	10 3/8"	12 15/32"
Length		mm	920	1,070
Weight		kg	6	7.5