



# BUILDING THE FUTURE

HIGH QUALITY CONSTRUCTION MACHINERY

**HOISTING EQUIPMENT  
CATALOGUE**

---

# MAST CLIMBERS

The PEC range is the perfect solution for façade restoration or closure works, being able to cover the perimeter of a building with circular, corner and zigzag configurations.

These platforms, made of galvanized steel, present benefits in terms of safety that facilitate work in adverse weather conditions. Compared to other lifting alternatives, the PECs reduce installation and disassembly time, as well as labor times, which increases productivity.

The electronic/electrical components and the motors of all our hoists are manufactured by European-based International brands, also available in North America. All our work platforms comply with the 2006/42CE and EN 1495 standards.

The PEC platform assumes low electrical consumption relative to its capabilities due to the use of high-efficiency gearmotors and low-weight components.

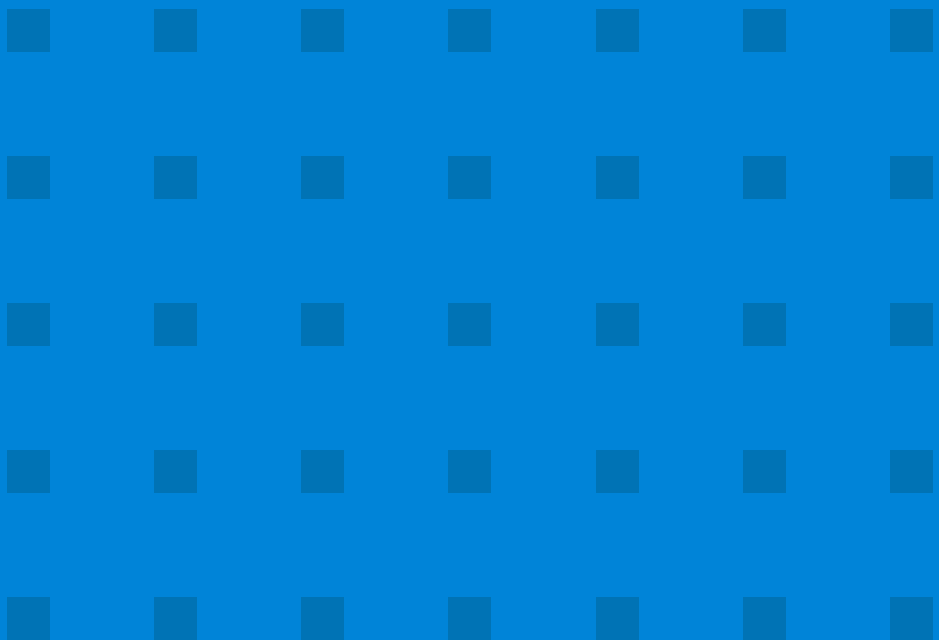

PEC 90



PEC 130

## PEC 120



## PEC 150

# PEC 90

## MINIMUM SIZE, MAXIMUM UTILITY

All the elements of the PEC 90 have been designed looking for the greatest ease of transport and mobility.

This platform can be lifted up to 90 m by a tube mast, compatible with other ALBA hoists, an advantage for our clients in terms of investment and stock.

### Main features:

- **Maximum length (twin mast):** 22,62 m.
- **Load capacity (twin mast):** 2100 kg.
- **Maximum speed:** 8,5 m/min.
- **Maximum height:** 120 m (ask us for greater heights).



# DATA SHEET PEC 90

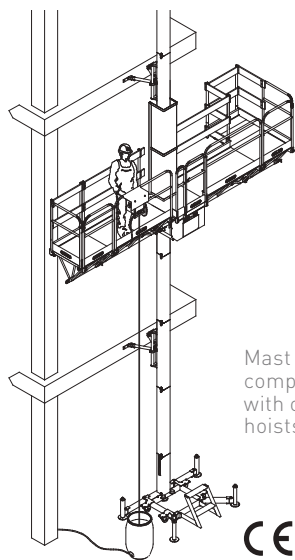

Mast compatible with other Alba hoists

Easy to transport, handling and assembly

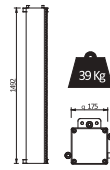

Platform with auxiliary extension

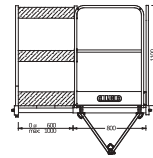

Panel with validating control system



Height-to-ground reduced

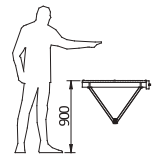

Main motor-group

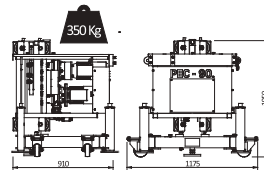

Platform module 1500

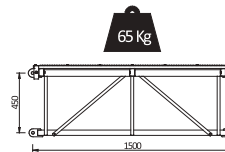

Platform module 820 / 510

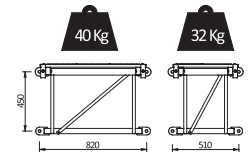

## TECHNICAL FEATURES

	SINGLE MAST	TWIN MAST
Maximum length	6,81 m	22,62 m
Maximum load	1.000 kg	2.100 kg
Vertical speed	7 m/min (50 Hz) // 8,5 m/min (60 Hz)	
Platform width	800 mm	
Platform extension	Standard: 600 mm Max.: 1.000 mm	
Motor power	2 x 0,75 kW (50 Hz) 2 x 0,90 kW (60 Hz)	4 x 0,75 kW (50 Hz) 4 x 0,90 kW (60 Hz)
Maximum height (*)	120 m (*)	
Anchorage each (max.)	6 m	
Height over last anchorage	1,5 m	
First anchorage height (max.)	6 m	
Loading height-to-ground	900 mm	
Regulations reference	2006/42/CE ; EN-1495	

## ELECTRICAL DATA

	SINGLE MAST		TWIN MAST	
	50 Hz	60 Hz	50 Hz	60 Hz
Motor power	2 x 0,75 kW	2 x 0,90 kW	4 x 0,75 kW	4 x 0,90 kW
Input power connection (**)	400 V - 50Hz	460 V - 60Hz(**)	400 V - 50Hz	460 V - 60Hz(**)
Power consumption	1,5 kW	1,8 kW	3 kW	3,6 kW
Nominal current	4 A		8 A	
Supply power	5 kVA		10 kVA	
Starting current	20 A		40 A	
Overload protection	4 x 16 A			
Differential protection Calibration Sensitivity	16 A 300 mA			
Control voltage	48 V			
Auxiliar handtools socket	230 V - 50Hz 16 A 265 V - 60Hz 16 A			
Cable section	5 x 2,5 mm <sup>2</sup>		5 x 4 mm <sup>2</sup>	

<b>MAST SECTION</b>	 <p><b>Single square tube</b> Length: 1,5 m Weight: 39 kg</p>	<p><b>Mast compatibility: (see p.50)</b> Transport platform: PT 450 Material hoist: MC 450</p>
---------------------	--	--

(\*) For greater heights, ask to manufacturer.

(\*\*) Transformer 220-460 V available for 220 V-60 Hz main supply. Ask to manufacturer.

Optional: Available single phase connection 230 V-1 ph-50/60 Hz. Single mast: 10 A / Twin mast: 20 A.

## SAFETY DEVICES INCLUDED AND OPTIONS

### INCLUDED

Gearmotors with electromechanical brake

Safety centrifugal brake

Emergency lowering lever

Platform door with automatic self-closing

Buffers at the ground base

Panel with validating control system

Upper/lower endtrack limit switch

Safety endtrack limit switch

Mast presence detector

Last mast without rack

Motor fault led and recovery push-button

Automatic leveling system

Platform floor of non-slipping galvanized steel

Movement warning horn

Phase control relay and warning led

Emergency stop

Base frame equipped with wheels

Auxiliary hand tools socket

Input power connector with phase quick-change

### OPTION

Platform extensión of special lenght

Modular floors for platform extension

Internal perimeter handrail posts

Safety networks to avoid falling materials

Angle 45° platform por special assemblies

Load limiter

Automatic greaser

# PEC 120

## EXCELLENT PERFORMANCE AT AN UNBEATABLE PRICE

The PEC 120 is our best-seller in this range due to its performance and reasonable price.

This platform is lifted by a triangle mast, compatible with other of our machines, such as the EPM 1000 and the PT 1200 passengers and material hoist and the MC 1000 material hoist.

### Main features:

- **Maximum length:** 9,99 m (single mast) and 32,11 m (twin mast).
- **Load capacity:** 1800 kg (single mast) and 4000 kg (twin mast).
- **Maximum speed:** 9 m/min.
- **Maximum height:** 120 m (ask us for greater heights).
- Variety of accessories for complex facades.



# DATA SHEET PEC 120

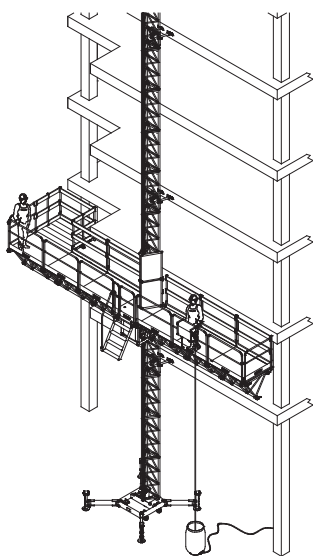

Mast compatible with other Alba hoists

High strength and reduced weight

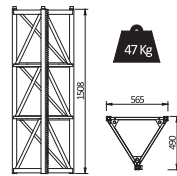

Platform with auxiliary extension

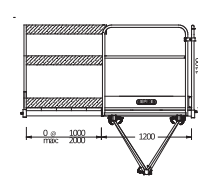

Panel with validating control system



Arrangement of anchors

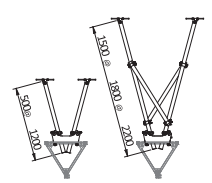

## DIMENSIONS AND WEIGHTS

Main motor-group

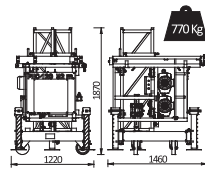

Platform module 1500

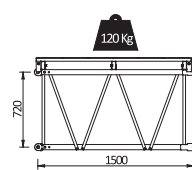

Platform module 820

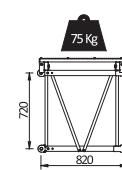

Platform module 510

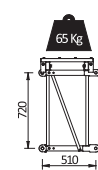

## TECHNICAL FEATURES

	SINGLE MAST	TWIN MAST
Maximum length	9,99 m	32,11 m
Maximum load	1.800 kg	4.000 kg
Vertical speed	7,5 m/min (50 Hz) 9 m/min (60 Hz)	
Platform width	1.200 mm	
Platform extension	Standard: 1.000 mm Max.: 2.000 mm	
Motor power	2 x 2,2 kW (50 Hz) 2 x 2,65 kW (60 Hz)	4 x 2,2 kW (50 Hz) 4 x 2,65 kW (60 Hz)
Maximum height (*)	120 m (*)	
Anchorage each (max.)	6 m	
Height over last anchorage	1,5 m	
First anchorage height (max.)	6 m	
Loading height-to-ground	1.500 mm	
Regulations reference	2006/42/CE ; EN-1495	

## ELECTRICAL DATA

	SINGLE MAST		TWIN MAST	
	50 Hz	60 Hz	50 Hz	60 Hz
Motor power	2 x 2,2 kW	2 x 2,65 kW	4 x 2,2 kW	4 x 2,65 kW
Input power connection (**)	400 V - 50 Hz	460 V - 60 Hz(**)	400 V - 50 Hz	460 V - 60 Hz(**)
Power consumption	4,4 kW	5,3 kW	8,8 kW	10,6 kW
Nominal current	12 A		24 A	
Supply power	10 kVA		20 kVA	
Starting current	66 A		132 A	
Overload protection	4 x 32 A			
Differential protection Calibre Sensitivity	32 A 300 mA			
Control voltage	48 V			
Auxiliar handtools socket	230 V - 50 Hz 16 A 265 V - 60 Hz 16 A			
Cable section	5 x 4 mm <sup>2</sup>		5 x 6 mm <sup>2</sup>	

<p><b>MAST SECTION</b></p>	<p><b>Triangle mast</b> Length: 1,5 m Weight: 47 kg</p>	<p><b>Mast compatibility: (see p.50)</b> Material hoist: MC 1000 Passengers &amp; material hoist: EPM 1000 Transport platform: PT 1200</p>
----------------------------	---	--

(\*) For greater heights, ask to manufacturer.

(\*\*) Transformer 220-460 V available for 220 V-60 Hz main supply. Ask to manufacturer.

## SAFETY DEVICES INCLUDED AND OPTIONS

### INCLUDED

- Gearmotors with electromechanical brake
- Safety centrifugal brake
- Emergency lowering lever
- Platform door with safety microswitch
- Buffers at the ground base
- Panel with validating control system
- Upper/lower endtrack limit switch
- Safety endtrack limit switch
- Mast presence detector
- Last mast without rack
- Automatic leveling system
- Platform floor of non-slipping galvanized steel
- Movement warning horn
- Phase control relay and warning led
- Emergency stop
- Base frame equipped with wheels
- Auxiliary hand tools socket
- Input power connector with phase quick-change

### OPTION

- Platform extension of special length
- Modular floors for platform extension
- Internal perimeter handrail posts
- Safety networks to avoid falling materials
- Angle 45° platform por special assemblies
- Jib-crane rail system for load handling
- Telescopic lateral handrail
- Load limiter
- Automatic greaser

# PEC 130

## ROBUSTNESS AND STABILITY

The PEC 130 has been designed with the combined features of other models in its range in order to optimize its benefits. It provides great stability and strength, and is elevated by a square mast, like the PEC 150.

This model is made up of a platform that is as long and light as the PEC 120 and of an intermediate chassis that allows reaching standard construction lengths to cover complete facades, greater load capacity and working height, as well as other functionalities.

### Main features:

- **Maximum length:** 13 m (single mat) and 34,32 m (twin mat).
- **Load capacity:** 2000 kg (single mat) and 4100 kg (twin mat).
- **Maximum speed:** 9 m/min.
- **Maximum height:** 250 m (ask us for greater heights).
- Possibility of installing two platforms on the same mast structure to work at double decker.
- Square mast compatible with: EDC 2000, PT 1800, PTB 3800, MC 2000 and PEC 150.



# DATA SHEET PEC 130

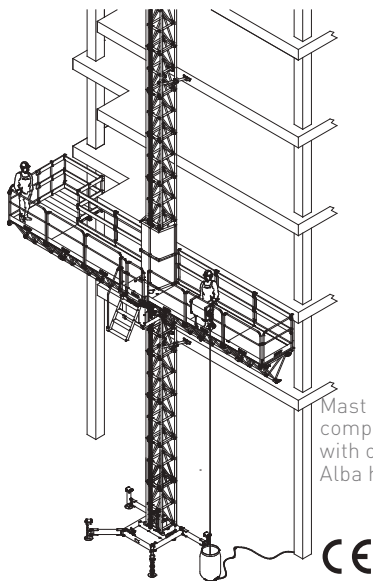

Mast compatible with other Alba hoists

Platform with auxiliary extension

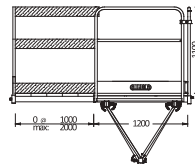

Panel with validating control system



Arrangement of anchors

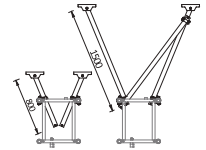

## DIMENSIONS AND WEIGHTS

Main motor-group

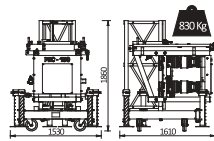

Platform module 1500

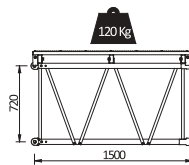

Platform module 820

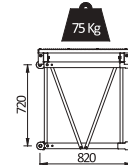

Platform module 510

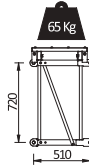

\*Modules compatible with model PEC 120.

## TECHNICAL FEATURES

	SINGLE MAST	TWIN MAST
Maximum length	13 m	34,32 m
Maximum load	2.000 kg	4.100 kg
Vertical speed	7,5 m/min (50 Hz) 9 m/min (60 Hz)	
Platform width	1.200 mm	
Platform extension (*)	Standard: 1.000 mm Max.: 2.000 mm (*)	
Motor power	2 x 2,2 kW (50 Hz) 2 x 2,65 kW (60 Hz)	4 x 2,2 kW (50 Hz) 4 x 2,65 kW (60 Hz)
Maximum height (**)	250 m (**)	
Anchorage each (max.)	12 m	
Height over last anchorage	1,5 m	
First anchorage height (max.)	9 m	
Loading height-to-ground	1.500 mm	
Regulations reference	2006/42/CE ; EN-1495	

## SAFETY DEVICES INCLUDED AND OPTIONS

### INCLUDED

- Gearmotors with electromechanical brake
- Safety centrifugal brake
- Emergency lowering lever
- Platform door with safety microswitch
- Buffers at the ground base
- Panel with validating control system
- Upper/lower endtrack limit switch
- Safety endtrack limit switch
- Mast presence detector
- Last mast without rack
- Automatic leveling system
- Platform floor of non-slipping galvanized steel
- Movement warning horn
- Phase control relay and warning led
- Emergency stop
- Base frame equipped with wheels
- Auxiliary hand tools socket
- Input power connector with phase quick-change

### OPTION

- Aux. crane for mast assembly
- Platform extension of special length
- Modular floors for platform extension
- Internal perimeter handrail posts
- Safety networks to avoid falling materials
- Angle 45° platform for special assemblies
- Jib-crane rail system for load handling
- Load limiter
- Automatic greaser

## ELECTRICAL DATA

	SINGLE MAST		TWIN MAST	
	50 Hz	60 Hz	50 Hz	60 Hz
Motor power	2 x 2,2 kW	2 x 2,65 kW	4 x 2,2 kW	4 x 2,65 kW
Input power connection (***)	400 V - 50Hz	460 V - 60Hz(***)	400 V - 50Hz	460 V - 60Hz(***)
Power consumption	4,4 kW	5,3 kW	8,8 kW	10,6 kW
Nominal current	12 A		24 A	
Supply power	10 kVA		20 kVA	
Starting current	66 A		132 A	
Overload protection	4 x 32 A			
Differential protection Calibre Sensitivity	32 A 300 mA			
Control voltage	48 V			
Auxiliar handtools socket	230 V - 50Hz 16 A 265 V - 60Hz 16 A			
Cable section	5 x 4 mm <sup>2</sup>		5 x 6 mm <sup>2</sup>	

### MAST SECTION



**Square mast**  
Length: 1,5 m  
Weight: 98 kg

**Mast compatibility: (see p.50)**  
Mast climber: PEC 150  
Material hoist: MC 2000  
Passengers & material hoist: EDC 1700/2000  
Transport platform: PT 1800 and PTB 3800

(\*) For longer floor extension, ask to manufacturer.

(\*\*) For greater heights, ask to manufacturer.

(\*\*\*) Transformer 220-460 V available for 220 V-60 Hz main supply. Ask to manufacturer.

# PEC 150

## GREAT LOAD CAPACITY

The PEC 150 is designed for heavy duty works. The width of the platform (1,5 m) and its powerful motors provide this model with working comfort and great load capacity. Features that are increased thanks to the square mast. To double the work capacity, an additional platform (double decker) can be installed on that mast.

### Main features:

- **Maximum length:** 13,65 m (single mast) and 37,80 m (twin mast).
- **Great load capacity:** 2700 kg (single mast) and 5000 kg (twin mast).
- **Speed:** 10 m/min.
- **Maximum height:** 250 m (ask us for greater heights).



# DATA SHEET PEC 150

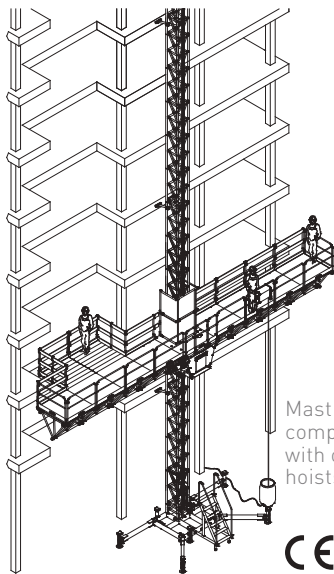

Mast compatible with other Alba hoists

Platform with auxiliary extension

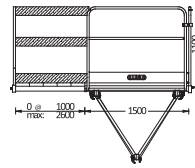

Panel with validating control system



Angle 45° platform for special assemblies

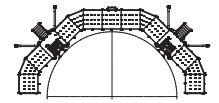

## DIMENSIONS AND WEIGHTS

Main motor-group

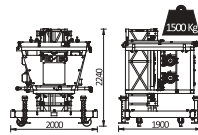

Platform module 1500

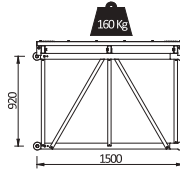

Platform module 820 / 510

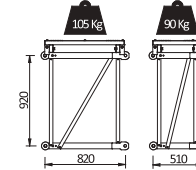

Arrangement of anchors

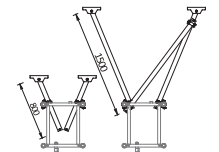

## TECHNICAL FEATURES

	SINGLE MAST	TWIN MAST
Maximum length	13,65 m	37,80 m
Maximum load	2.700 kg	5.000 kg
Vertical speed	10 m/min	
Platform width	1.500 mm	
Platform extension	Standard: 1.000 mm Max: 2.600 mm	
Motor power	2 x 3 kW [50 Hz] 2 x 3,6 kW [60 Hz]	4 x 3 kW [50 Hz] 4 x 3,6 kW [60 Hz]
Maximum height (*)	250 m (*)	
Anchorage each (max.)	12 m	
Height over last anchorage	1,5 m	
First anchorage height (max.)	9 m	
Loading height-to-ground	2.000 mm	
Regulations reference	2006/42/CE ; EN-1495	

## ELECTRICAL DATA

	SINGLE MAST		TWIN MAST	
	50 Hz	60 Hz	50 Hz	60 Hz
Motor power	2 x 3 kW	2 x 3,6 kW	4 x 3 kW	4 x 3,6 kW
Input power connection (**)	400 V - 50Hz	460 V-60Hz(**)	400 V - 50Hz	460 V-60Hz(**)
Power consumption	6 kW	7,2 kW	12 kW	14,4 kW
Nominal current	14 A		28 A	
Supply power	15 kVA		25 kVA	
Starting current	70 A		140 A	
Overload protection	4 x 32 A			
Differential protection Calibre Sensitivity	32 A 300 mA			
Control voltage	48 V			
Auxiliar handtools socket	230 V - 50Hz 16 A 265 V - 60Hz 16 A			
Cable section	5 x 4 mm <sup>2</sup>		5 x 6 mm <sup>2</sup>	

<b>MAST SECTION</b>	 <p><b>Square mast</b> Length: 1,5 m Weight: 98 kg</p>	<p><b>Mast compatibility: (see p.50)</b> Mast climber: PEC 130 Material hoist: MC 2000 Passengers &amp; material hoist: EDC 1700/2000 Transport platform: PT 1800 and PTB 3800</p>
---------------------	---	--

(\*) For greater heights, ask to manufacturer.

(\*\*) Transformer 220-460 V available for 220 V-60 Hz main supply. Ask to manufacturer.

## SAFETY DEVICES INCLUDED AND OPTIONS

- \_\_\_\_\_ Gearmotors with electromechanical brake
- \_\_\_\_\_ Safety centrifugal brake
- \_\_\_\_\_ Emergency lowering lever
- \_\_\_\_\_ Platform door with safety microswitch
- \_\_\_\_\_ Buffers at the ground base
- \_\_\_\_\_ Panel with validating control system
- \_\_\_\_\_ Upper/lower endtrack limit switch
- \_\_\_\_\_ Safety endtrack limit switch
- \_\_\_\_\_ Mast presence detector
- \_\_\_\_\_ Last mast without rack
- \_\_\_\_\_ Automatic leveling system
- \_\_\_\_\_ Platform floor of non-slipping galvanized steel
- \_\_\_\_\_ Movement warning horn
- \_\_\_\_\_ Phase control relay and warning led
- \_\_\_\_\_ Emergency stop
- \_\_\_\_\_ Base frame equipped with wheels
- \_\_\_\_\_ Auxiliary hand tools socket
- \_\_\_\_\_ Input power connector with phase quick-change

## OPTION

- \_\_\_\_\_ Aux. crane for mast assembly
- \_\_\_\_\_ Platform extension of special length
- \_\_\_\_\_ Modular floors for platform extension
- \_\_\_\_\_ Internal perimeter handrail posts
- \_\_\_\_\_ Safety networks to avoid falling materials
- \_\_\_\_\_ Angle 45° platform por special assemblies
- \_\_\_\_\_ Jib-crane rail system for load handling
- \_\_\_\_\_ Telescopic lateral handrail
- \_\_\_\_\_ Load limiter
- \_\_\_\_\_ Automatic greaser

# LOAD DIAGRAM

## PEC 90

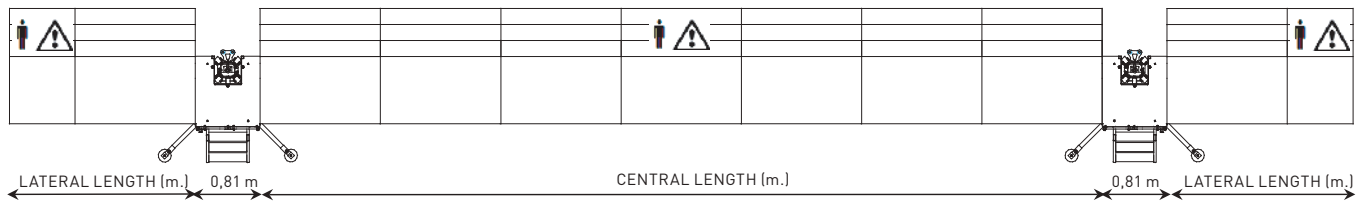

### PEC 90 TWIN MAST

Lateral modules x2	Modules (m)	LOADING EXAMPLES	
		Total length (m)	Maximum load (kg)
1 x 0,82 m	2 x 1,5	6,26	2.100
	2 x 1,5 + 1 x 0,82	7,08	2.050
	3 x 1,5	7,76	2.000
	3 x 1,5 + 1 x 0,82	8,58	1.950
1 x 1,5 m	4 x 1,5	10,62	1.700
	4 x 1,5 + 1 x 0,82	11,44	1.650
	5 x 1,5	12,12	1.600
	5 x 1,5 + 1 x 0,82	12,94	1.550
1 x 1,5 m + 1 x 0,82 m	6 x 1,5	15,26	1.200
	6 x 1,5 + 1 x 0,82	16,08	1.150
	7 x 1,5	16,76	1.125
	7 x 1,5 + 1 x 0,82	17,58	1.100
2 x 1,5 m	8 x 1,5	19,62	975
	8 x 1,5 + 1 x 0,82	20,44	950
	9 x 1,5	21,12	900
	9 x 1,5 + 1 x 0,82	21,94	850
	10 x 1,5	22,62	800

#### Weights for full length extension floor

(If they are assembled, their weight must be subtracted from the maximum load for every configuration)

Machine length (m)	22,62	21,94	21,12	20,44	19,62	17,58	16,76	16,08	15,26	12,94	12,12	11,44	10,62	8,58	7,76	7,08	6,26
Weight for full length extension (kg)	252	245	234	227	216	195	183	176	165	137	126	119	108	86	75	68	57

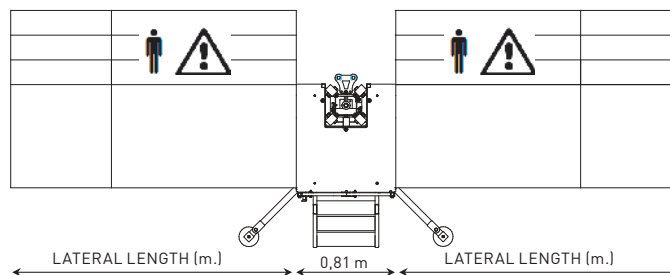

### PEC 90 SINGLE MAST

Modules (m)	LOADING EXAMPLES	
	Total length (m)	Maximum load (kg)
1 x 0,82	2,45	1.000
1 x 1,5	3,81	800
1 x 1,5 m + 1 x 0,82	5,45	500
2 x 1,5	6,81	400

#### Weights for full length extension floor

(If they are assembled, their weight must be subtracted from the maximum load for every configuration)

Longitud de máquina (m)	6,81	5,45	3,81	2,45
Weight for full length extension (kg)	72	58	36	22

- Set ups in this table are merely informative and may vary due to machine modularity.
- Load values include personnel, tools and materials weight.
- Extensions of platform decks shall only be used while working. Placing loads on them is forbidden.
- Loads must be evenly distributed along the platform.
- On single mast set ups, lateral lengths shall be identical.
- The maximum allowed force for hand tools used in the work platform is 1500 n.

# LOAD DIAGRAM

## PEC 120

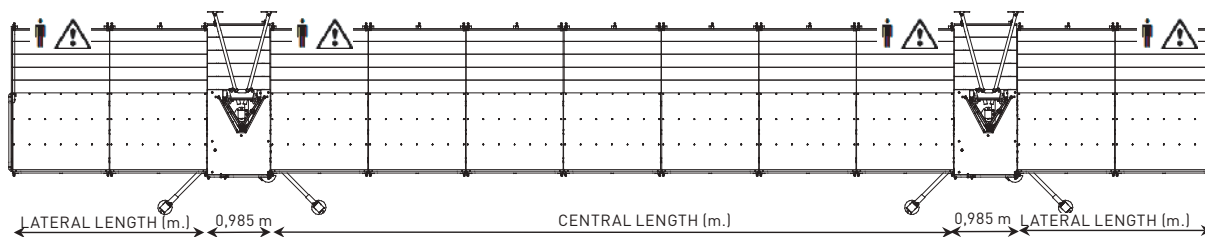

### PEC 120 TWIN MAST

Lateral modules x2	Modules (m)	LOADING EXAMPLES	
		Total length (m)	Maximum load (kg)
1 x 1,5 m	4 x 1,5	10,97	4000
	4 x 1,5 + 1 x 0,82	11,79	3900
	5 x 1,5	12,47	3800
	5 x 1,5 + 1 x 0,82	13,29	3700
1 x 1,5 m + 1 x 0,82 m	6 x 1,5 m	15,61	3600
	6 x 1,5 + 1 x 0,82	16,43	3500
	7 x 1,5	17,11	3450
2 x 1,5 m	7 x 1,5 + 1 x 0,82	17,93	3350
	8 x 1,5	19,97	3100
	8 x 1,5 + 1 x 0,82	20,79	3000
	9 x 1,5	21,47	2950
2 x 1,5 m + 1 x 0,82 m	9 x 1,5 + 1 x 0,82	22,29	2875
	10 x 1,5	24,61	2700
	10 x 1,5 m + 1 x 0,82	25,43	2600
2 x 1,5 m + 1 x 0,82 m	11 x 1,5	26,11	2500
	11 x 1,5 + 1 x 0,82	26,93	2350
	12 x 1,5	28,97	2175
	12 x 1,5 + 1 X 0,82	29,79	2075
2 x 1,5 m + 1 x 0,82 m	13 x 1,5	30,47	2000
	13 x 1,5	32,11	1700

**Weights for full length extension floor**  
 (If they are assembled, their weight must be subtracted from the maximum load for every configuration)

Machine length (m)	32,11	30,47	28,97	26,93	25,43	24,61	22,29	21,47	19,97	17,93	16,43	15,61	13,29	12,47	10,97
Weight for full length ext. (kg.)	605	570	540	502,5	472,5	455	407,5	390	360	322,5	292,5	275	227,5	210	180

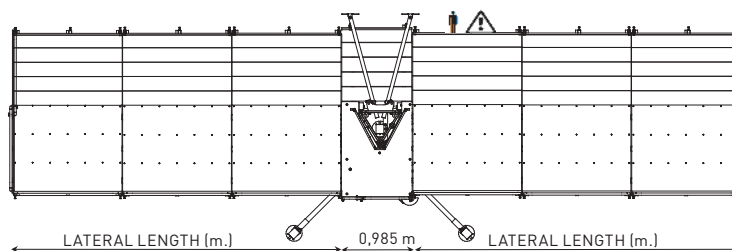

### PEC 120 SINGLE MAST

Modules (m)	LOADING EXAMPLES	
	Total length (m)	Maximum load (kg)
1 x 0,82	2,63	1800
1 x 1,5	3,99	1700
1 x 1,5 + 1 x 0,82	5,63	1550
2 x 1,5	6,99	1400
2 x 1,5 + 1 x 0,82	8,63	1200
3 x 1,5	9,99	1100

**Weights for full length extension floor**  
 (If they are assembled, their weight must be subtracted from the maximum load for every configuration)

Machine length (m)	9,99	8,63	6,99	5,63	3,99	2,63
Weight for full length ext. (kg.)	180	155	120	95	60	35

- Set ups in this table are merely informative and may vary due to machine modularity.
- Load values include personnel, tools and materials weight.
- Extensions of platform decks shall only be used while working. Placing loads on them is forbidden.
- Loads must be evenly distributed along the platform.
- On single mast set ups, lateral lengths shall be identical.
- The maximum allowed force for hand tools used in the work platform is 1500 n.

## LOAD DIAGRAM

### PEC 130

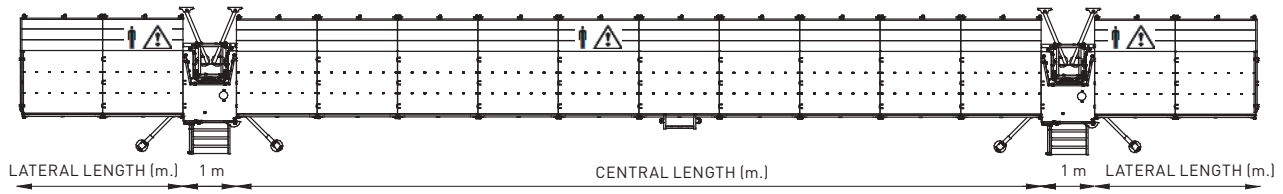

### PEC 130 TWIN MAST

Lateral modules x2	Modules (m)	LOADING EXAMPLES	
		Total length (m)	Maximum load (kg)
1 x 1,5 m	5 x 1,5	12,50	4100
	6 x 1,5	14,00	3950
	7 x 1,5	15,50	3800
1 x 1,5 m + 1 x 0,82 m	7 x 1,5	17,14	3600
	8 x 1,5	18,64	3400
2 x 1,5 m	8 x 1,5	20,00	3200
	9 x 1,5	21,50	3050
	10 x 1,5	23,00	2900
2 x 1,5 m + 1 x 0,82 m	10 x 1,5	24,64	2700
	11 x 1,5	26,14	2500
3 x 1,5 m	11 x 1,5	27,50	2400
	12 x 1,5	29,00	2175
	13 x 1,5	30,50	2000
3 x 1,5 m + 1 x 0,82 m	13 x 1,5	32,14	1950
	13 x 1,5	33,50	1900
4 x 1,5 m	13 x 1,5 + 1 x 0,82	34,32	1800

#### Weights for full length extension floor

(If they are assembled, their weight must be subtracted from the maximum load for every configuration)

Machine length (m)	34,32	33,50	32,14	30,50	29,00	27,50	26,14	24,64	23,00	21,50	20,00	18,64	17,14	15,50	14,00	12,50
Weight for full length ext. (kg.)	755	735	705	665	630	595	565	530	490	455	420	390	355	315	280	245

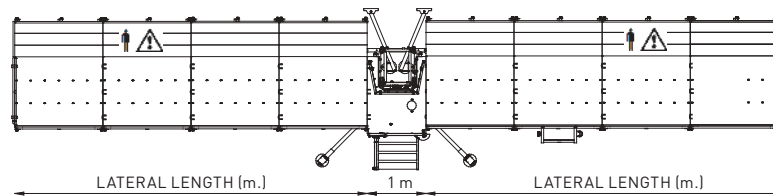

### PEC 130 SINGLE MAST

Modules (m)	LOADING EXAMPLES	
	Total length (m)	Maximum load (kg)
1 x 0,82	2,64	2000
1 x 1,5	4,00	1880
1 x 1,5 + 1 x 0,82	5,64	1600
2 x 1,5	7,00	1400
2 x 1,5 + 1 x 0,82	8,64	1200
3 x 1,5	10,00	1100
3 x 1,5 + 1 x 0,82	11,64	1050
4 x 1,5	13,00	1000

#### Weights for full length extension floor

(If they are assembled, their weight must be subtracted from the maximum load for every configuration)

Machine length (m)	13,00	11,64	10,00	8,64	7,00	5,64	4,00	2,64
Weight for full length ext. (kg.)	280	250	210	180	140	110	70	40

- Set ups in this table are merely informative and may vary due to machine modularity.
- Load values include personnel, tools and materials weight.
- Extensions of platform decks shall only be used while working. Placing loads on them is forbidden.
- Loads must be evenly distributed along the platform.
- On single mast set ups, lateral lengths shall be identical.
- The maximum allowed force for hand tools used in the work platform is 1500 n.

# LOAD DIAGRAM

## PEC 150

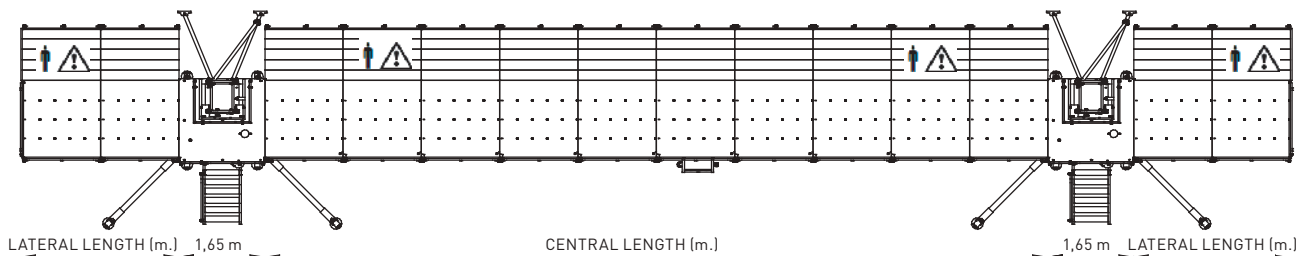

### PEC 150 TWIN MAST

Lateral modules x2	Modules (m)	LOADING EXAMPLES	
		Total length (m)	Maximum load (kg)
1 x 1,5 m	5 x 1,5	13,80	5000
	6 x 1,5	15,30	4800
	7 x 1,5	16,80	4625
1 x 1,5 m + 1 x 0,82 m	7 x 1,5	18,44	4475
	8 x 1,5	19,94	4300
2 x 1,5 m	8 x 1,5	21,30	4150
	9 x 1,5	22,80	3975
	10 x 1,5	24,30	3800
2 x 1,5 m. + 1 x 0,82 m	10 x 1,5	25,94	3650
	11 x 1,5	27,44	3475
3 x 1,5 m	11 x 1,5	28,80	3325
	12 x 1,5	30,30	3130
	13 x 1,5	31,80	2975
3 x 1,5 m + 1 x 0,82 m	13 x 1,5	33,40	2825
	14 x 1,5	34,94	2650
4 x 1,5 m	14 x 1,5	36,30	2500
	15 x 1,5	37,80	2300

#### Weights for full length extension floor

(If they are assembled, their weight must be subtracted from the maximum load for every configuration)

Machine length (m)	37,80	36,30	34,94	33,44	31,80	30,30	28,80	27,44	25,94	24,30	22,80	21,30	19,94	18,44	16,80	15,30	13,80
Weight for full length ext. (kg.)	805	770	740	705	665	630	595	565	530	490	445	420	0	355	315	280	245

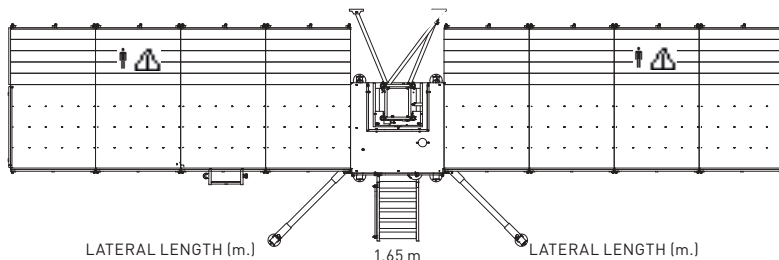

### PEC 150 SINGLE MAST

Modules (m)	LOADING EXAMPLES	
	Total length (m)	Maximum load (kg)
1 x 0,82	3,29	2700
1 x 1,5	4,65	2300
1 x 1,5 + 1 x 0,82	6,29	2000
2 x 1,5	7,65	1900
2 x 1,5 + 1 x 0,82	9,29	1700
3 x 1,5	10,65	1600
3 x 1,5 + 1 x 0,82	12,29	1400
4 x 1,5	13,65	1200

#### Weights for full length extension floor

(If they are assembled, their weight must be subtracted from the maximum load for every configuration)

Machine length (m)	13,65	12,29	10,65	9,29	7,65	6,29	4,65	3,29
Weight for full length ext. (kg.)	280	250	210	180	140	110	70	40

- Set ups in this table are merely informative and may vary due to machine modularity.
- Load values include personnel, tools and materials weight.
- Extensions of platform decks shall only be used while working. Placing loads on them is forbidden.
- Loads must be evenly distributed along the platform.
- On single mast set ups, lateral lengths shall be identical.
- The maximum allowed force for hand tools used in the work platform is 1500 n.

---

# MATERIAL HOISTS

MC 250

The material hoists are used to lift material vertically in construction and restoration projects and are characterized by their **smooth transport and the speed and simplicity of assembly**.

Our experience allows us to adapt to the needs of the customer and thus create hoists custom loading. The MC range of hoists climb the mast by means of the rack and pinion system, thus eliminating all the problems derived from cable lifts. The latest safety technology is used by incorporating an overspeed parachute with auto-recovery system.

The electronic/electrical components and the motors of all our hoists are manufactured by European-based International brands, also available in North America. All our hoists are made of galvanized steel and comply with the 2006/42CE and UNE-EN 12158 standards.



MC 450



MC 1000



MC 2000



# MC 250

## DESIGNED FOR INSTALLATION INSIDE TUBULAR SCAFFOLDING

The MC 250 model is compatible with all brands and types of scaffolding on the market. It can be equipped with different interchangeable carriers (standard carrier, easy access carrier with pivoting panels and system scaffold transport cage), depending on the type of loads to be lifted or the needs of the work to be completed.

### Main features:

- **Load capacity:** 250 kg.
- **Standard carrier dimensions:** 900 x 500 x 900 mm.
- **Easy access carrier dimensions:** 1.300 x 800 x 1.100 mm.
- **System scaffold cage dimensions:** 900 x 500 x 1.800 mm.
- **Maximum speed:** 20 m/min.
- **Maximum height:** 70 m (ask us for greater heights).
- It climbs the "ladder" mast.



# DATA SHEET MC 250



CE

Carrier designed for transport bulky loads



Installation dimensions inside scaffold

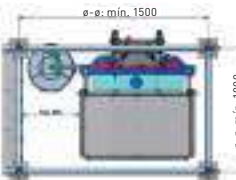

Carrier built in galvanized steel and aluminium



Installation dimensions in hollow



Overspeed parachute with auto-recovery system



Base set for transport



## TECHNICAL FEATURES

Maximum capacity (*)	250 kg(*)
Vertical speed	20 m/min
Standard carrier dimensions (LxWxH) (**)	900 x 500 x 900 mm (**)
Easy access carrier dimension (LxWxH)	1.300 x 800 x 1.100 mm
System scaffold cage dimensions (LxWxH)	900 x 500 x 1.800 mm
Motor power	1,5 kW (50 Hz) 1,8 kW (60 Hz)
Standard maximum height (***)	70 m (***)
Anchorage each (max.)	2 m
Anchorage each (max.)	1 m
Noise emission value	<70 dB
Regulations reference	2006/42/CE

## ELECTRICAL DATA

	50 Hz	60 Hz
Motor power	1,5 kW	1,8 kW
Input power connection	1: 230 V – 50Hz	1~: 220 V – 60Hz
Nominal current	10 A	10 A
Supply power	5 kVA	
Starting capacitor	160 $\mu$ F	
Running capacitor	70 $\mu$ F	
Overload protection	2 x 16 A	
Differential protection Calibration Sensitivity	16 A 300 mA	
Control voltage	48 V	

<b>MAST SECTION</b>		<b>Flat mast</b> Length: 2 m Weight: 25 kg
---------------------	---	--

(\*) Depending on type of carrier selected.  
 (\*\*) For other dimensions, ask to manufacturer.  
 (\*\*\*) For higher installation, ask to manufacturer.

## SAFETY DEVICES INCLUDED AND OPTIONS

	INCLUDED	OPTION
<b>GENERAL</b>		
Gearmotor with electromechanical brake	✓	
Overspeed parachute with auto-recovery system	✓	
Emergency lowering lever	✓	
LED for fault detection	✓	
Buffers at the ground base	✓	
Upper endtrack buffers	✓	
Upper/lower endtrack limit switch	✓	
Safety endtrack limit switch	✓	
Mast presence detector	✓	
Motor with thermal protector	✓	
Emergency stop	✓	
Kit for installation of 3 –intermediate stops in mast		✓

### ACCESSIBLE CAGE

Cage door with electrical interlock	✓
Cage floor of non-slipping material	✓
Landing doors with electrical interlock	✓

Accessible cage with 90° rotation in both directions



# MC 450

## SUITABLE FOR TIGHT SPACES (ELEVATOR SHAFT)

The MC 450 is lifted by a square tube mast, compatible with the PT 450 transport platform for passengers and materials and the PEC 90 mast climber, which represents an advantage for our customers in terms of investment and stock.

### Main features:

- **Load capacity:** 450 kg.
- **Cabin dimensions:** 1240 x 840 mm.
- **Maximum speed:** 20 m/min.
- **Maximum height:** 120 m (ask us for greater heights).



## DATA SHEET MC 450

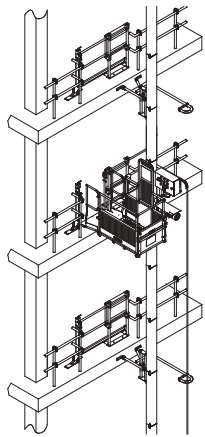

Mast compatible with other Alba hoists



CPU and automatic floor management



Installation dimensions

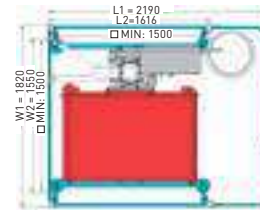

Landing levels call system



Overspeed parachute with auto-recovery system



Folding ramps with automatic side protection

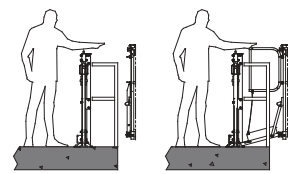

## TECHNICAL FEATURES

	MC 450	MC 450-1F
Maximum capacity	450 kg	
Vertical speed	17 m/min (50 Hz) 20 m/min (60 Hz)	
Cage dimensions (LxW)	1.240 x 840 mm	
Minimum hoistway	□ 1.500 x 1.500 mm	
Motor power	2,2 kW (50 Hz) 2,65 kW (60 Hz)	2,2 kW
Motor control	DIRECT	FREQUENCY CONVERTER
Maximum height (*)	120 m (*)	
Anchorage each (max.)	6 m	
Height over last anchorage	1,5 m	
First anchorage height	4 m	
Minimum load height	350 mm	
Maximum load (assembly)	200 kg	
Noise emission value	<70 dB	
Regulations reference	2006/42/CE ; EN-12158	

## SAFETY DEVICES INCLUDED AND OPTIONS

	INCLUDED	OPTION
Gearmotor with electromechanical brake	✓	
Overspeed parachute with auto-recovery system	✓	
Emergency lowering lever	✓	
Cage door with automatic side protection	✓	
Landing doors with mechanical / electrical interlock		✓
Base frame enclosure		✓
Hoist control display with signaling LEDs:	✓	
- Cage door open		
- Landing door open		
- Enf of mast		
- Upper/lower endtrack		
- Aux. Crane interfering		
- Last 2 m zone		
- Overspeed parachute		
- Cage overload		
- Motor overheat fault		
- Hoist free / busy		
Automatic floor management	✓	
Buffers at the ground base	✓	
Hoist control CPU, with event log	✓	
Upper/lower endtrack limit switch	✓	
Safety endtrack limit switch	✓	
Overload detection device		✓
Mast presence switch	✓	
Last mast without rack	✓	
Motor with brake wear signal		✓
Cage floor of non-slipping galvanized steel	✓	
Phase control	✓	
Emergency stop	✓	
Landing levels call system		✓
Parachute test remote control		✓
Automatic greaser		✓

## ELECTRICAL DATA

	MC 450		MC 450-1F
	50 Hz	60 Hz	50/60 Hz
Motor power	2,2 kW	2,65 kW	2,2 kW
Input power connection	400 V - 50Hz	220 V - 60Hz 440 V - 60Hz	1F230 V - 50/60Hz
Power consumption	2,2 kW	2,65 kW	4 kW
Nominal current	6 A	12 / 6 A	13 A
Supply power	8 kVA		
Starting current	33 A	66/33 A	-
Overload protection	4 x 10 A	4 x 16/10 A	2 x 16 A
Differential protection Calibre Sensitivity	10 A 300 mA	16/10 A 300 mA	16 A 300 mA
Control voltage	48 V		
Auxiliar handtools socket	230 V - 50/60 Hz 16 A		
Cable section	5 x 2,5 mm <sup>2</sup>	4 x 4 / 6 x 2,5 mm <sup>2</sup>	3 x 4 mm <sup>2</sup>

## MAST SECTION



Single square tube  
Length: 1,5 m  
Weight: 39 kg

Mast compatibility: (see p.50)  
Mast climber: PEC 90  
Transport platform: PT 450

(\*) For greater heights, ask to manufacturer.

# MC 1000

## A VERY VERSATILE ELEVATOR

The MC 1000 material hoist can be used to lift loads both in new construction and in rehabilitation.

Also suitable for transporting drywall (the MC 1000F version), this hoist is lifted by a triangle mast, compatible with the PEC 120 work platform and the PT 1200 and the EPM 1000 passengers and material hoist.

### Main features:

- **Load capacity:** 1000 kg.
- **Cabin dimensions:** 2000 x 1750 mm (MC 1000) or 2500 x 1400 mm (MC 1000F).
- **Maximum speed:** 20 m/min.
- **Maximum height:** 120 m (ask us for greater heights).



# DATA SHEET MC 1000

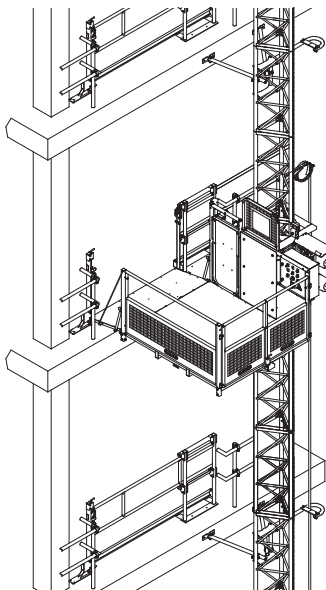

Mast compatible with other Alba hoists



Finished in hot galvanized steel



CPU and automatic floor management



Landing levels call system



Overspeed parachute with auto-recovery system



Installation dimensions

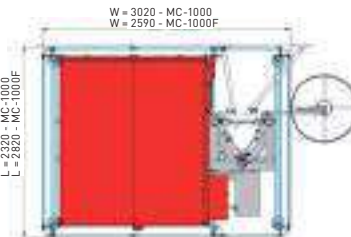

Landing doors with mechanical / electrical interlock

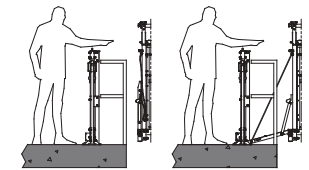

## TECHNICAL FEATURES

	MC 1000	MC 1000F
Maximum capacity	1.000 kg	
Vertical speed	20 m/min	
Cage dimensions (LxW)	2.000 x 1.750 mm	2.500 x 1.400 mm
Motor power	2 x 3 kW (50 Hz) 2 x 3,6 kW (60 Hz)	
Motor control	DIRECT	
Maximum height (*)	120 m (*)	
Anchorage each (max.)	6 m	
Height over last anchorage	1,5 m	
First anchorage height	6 m	
Minimum load height	400 mm	
Maximum load (assembly)	300 kg	
Noise emission value	<70 dB	
Regulations reference	EN-12158 ; 2006/42/CE	

## ELECTRICAL DATA

	50 Hz	60 Hz
Motor power	2 x 3 kW	2 x 3,6 kW
Input power connection	400 V - 50Hz	440 V - 60Hz // 380 V - 60Hz
Power consumption	6 kW	7,2 kW
Nominal current	14 A	15 A // 17 A
Supply power	20 kVA	
Starting current	77 A	83 A // 97 A
Overload protection	4 x 25 A	4 x 25 A
Differential protection Calibre Sensitivity	25 A 300 mA	25 A 300 mA
Control voltage	48 V	
Auxiliar handtools socket	230 V - 50/60 Hz 16 A	
Cable section	5 x 6 mm <sup>2</sup>	

### MAST SECTION

**Triangle mast**  
Length: 1,5 m  
Weight: 47 kg

**Mast compatibility:** (see p.50)  
Mast climber: PEC 120  
Passengers & material hoist: EPM 1000  
Transport platform: PT 450

(\*) For greater heights, ask to manufacturer.

## SAFETY DEVICES INCLUDED AND OPTIONS

	INCLUDED	OPTION
<b>GENERALS</b>		
Gearmotors with electromechanical brake	✓	
Overspeed parachute with auto-recovery system	✓	
Emergency lowering lever	✓	
3rd. door on cage (front side)		✓
Landing doors with mechanical / electrical interlock		✓
Base enclosure with electrical interlock		✓
Hoist control display with signaling LEDs:	✓	
- Cage door open		
- Landing door open		
- Enf of mast		
- Upper/lower endtrack		
- Aux. Crane interfering		
- Last 2 m zone		
- Overspeed parachute		
- Cage overload		
- Motor overheat fault		
- Hoist free / busy		
Automatic floor management		✓
Buffers at the ground base		✓
Hoist control CPU, with event log		✓
Upper/lower endtrack limit switch	✓	
Safety endtrack limit switch	✓	
Overload detection device		✓
Mast presence switch	✓	
Last mast without rack	✓	
Aux. catwalk for anchorage assembly	✓	
Aux. crane for mast assembly		✓
Motors with brake wear signal		✓
Cage floor of non-slipping galvanized steel	✓	
Phase control	✓	
Emergency stop	✓	
Landing levels call system		✓
Parachute test remote control		✓
Automatic greaser		✓

# MC 2000

## SUITABLE FOR LARGE BUILDING SITES

This material hoist, also available in a version to lift drywall (the MC 2000F version), can work simultaneously with another lift on the same square mast, compatible with the EDC 2000 and the PT 1800 passengers and material hoists and the work platforms PEC 130 and 150.

### Main features:

- **Load capacity:** 2000 kg.
- **Cabin dimensions:** 3200 x 1400 mm.
- Cabin up to 4 m in length.
- **Maximum speed:** 20 m/min.
- **Maximum height:** 250 m (ask us for greater heights).







---

# PASSENGERS & MATERIAL HOISTS

ALBA passengers and material hoists are divided into 3 parts: the **PT range**, the **EDC, EPM and PMH** models and the **EG 250** crane operator lift; all of them are made of galvanized steel.

The electronic/electrical components and the motors of all our hoists are manufactured by European-based International brands, also available in North America. All our hoists for passengers and material comply with the 2006/42 CE and UNE-EN 12159 standards.

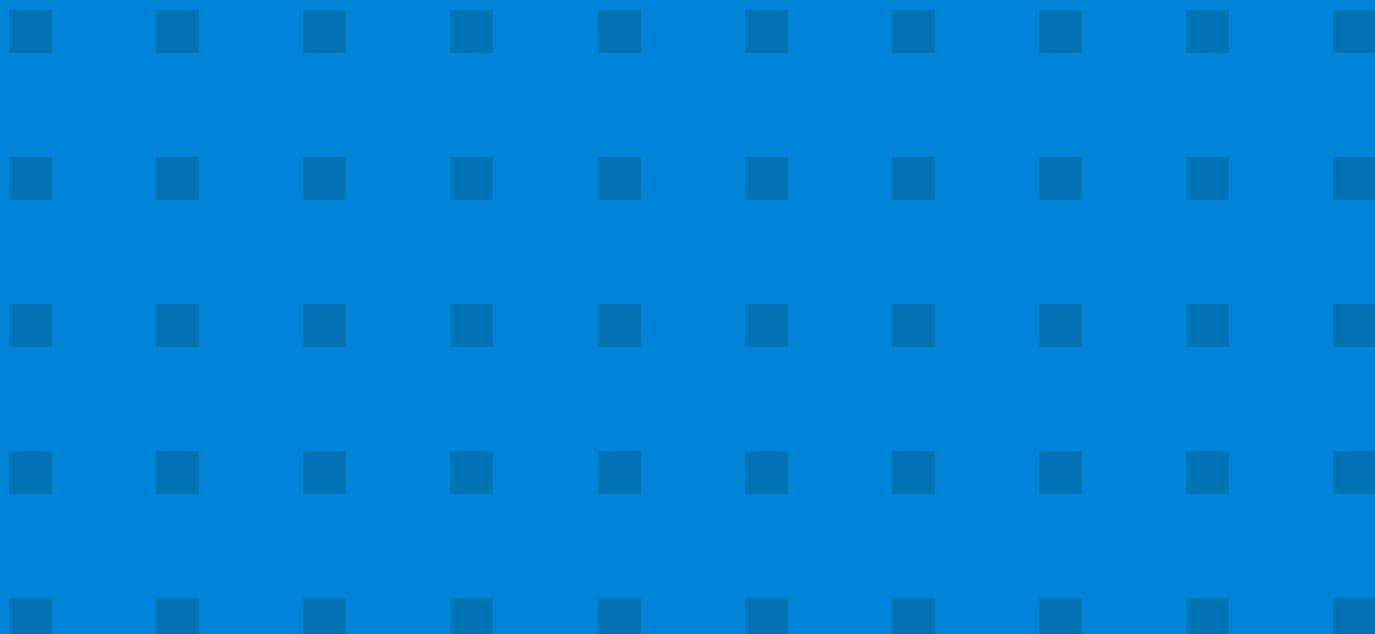

## TRANSPORT PLATFORMS (PT)



PT 450



PT 1200



PT 1800



PTB 3800

## CRANE OPERATOR LIFT



EG 250

## ENCLOSE CABIN HOISTS



EPM 1000



EDC 2000 Twin cabin

PMH

# PT 450

## THE BEST SOLUTION FOR TRANSPORTATION OF PASSENGERS AND MATERIAL IN MEDIUM-HEIGHT BUILDINGS

With a load capacity of 450 kg and small foot print, this transport platform is ideal for lifting men and/or materials in confined spaces, such as elevator shafts. This, along with a budget friendly price, makes the hoist highly productive and profitable.

### Main features:

- **Load capacity:** 450 kg.
- **Cabin dimensions:** 1240 x 840 x 2020 mm.
- **Maximum speed:** 20 m/min.
- **Maximum height:** 120 m (ask us for greater heights).
- Square tube mast compatible with the MC 450 material hoist and the PEC 90 mast climber.



# DATA SHEET PT 450

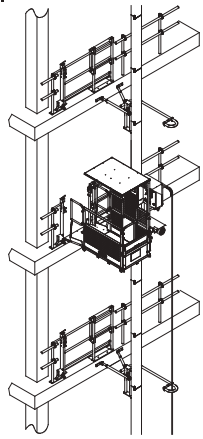

Mast compatible with other Alba hoists



CPU and automatic floor management



Landing levels call system



Installation dimensions

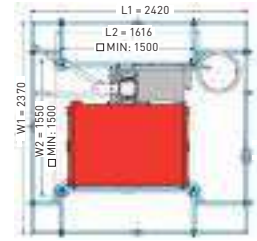

Overspeed parachute with auto-recovery system



Folding ramps with automatic side protection

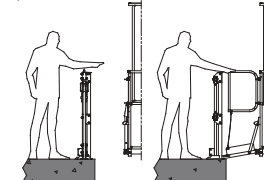

Dual operation mode: persons - loads



## TECHNICAL FEATURES

	PT 450-2V	PT 450-1V
Maximum capacity	2 pax + 250 kg 450 kg	5 pax 450 kg
Vertical speed	12÷18 m/min	17 m/min (50 Hz) 20 m/min (60 Hz)
Cage dimensions (LxWxH)	1.240 x 840 x 2.020 mm	
Minimum hoistway	□1.500 x 1.500 mm	
Motor power	2,2 kW (50 Hz)	2,2 kW (50 Hz) 2,65 kW (60 Hz)
Motor control	FREQUENCY CONVERTER	DIRECT
Maximum height (*)	120 m (*)	
Anchorage each (max.)	6 m	
Height over last anchorage	1,5 m	
First anchorage height	4 m	
Loading height-to-ground	400 mm	
Maximum load (assembly)	200 kg	
Noise emission value	<70 dB	
Regulations reference	2006/42/CE	EN-12158

## ELECTRICAL DATA

	PT 450-2V		PT 450-1V	
	50/60 Hz	50 Hz	60 Hz	60 Hz
Motor power	2,2 kW	2,2 kW	2,65 kW	2,65 kW
Input power connection	380÷460V - 50/60Hz	400 V - 50Hz	440 V - 60Hz	220 V - 60Hz
Power consumption	4 kW	2,2 kW	2,65 kW	2,65 kW
Nominal current	10 A	6 A	6 / 12 A	6 / 12 A
Supply power	8 kVA	8 kVA		8 kVA
Starting current	-	33 A	33/66 A	33/66 A
Overload protection	4 x 16 A	4 x 10 A	4 x 10/16 A	4 x 10/16 A
Differential protection Calibration Sensitivity	16 A 300 mA	10 A 300 mA	10/16 A 300 mA	10/16 A 300 mA
Control voltage	48 V			
Auxiliar handtools socket	230 V - 50/60 Hz 16 A			
Cable section	5 x 4 mm <sup>2</sup>	5 x 2,5 mm <sup>2</sup>	4x 4/6x 2,5 mm <sup>2</sup>	

<b>MAST SECTION</b> 	<b>Single square tube</b> Length: 1,5 m Weight: 39 kg	<b>Mast compatibility: (see p.50)</b> Mast climber: PEC 90 Material hoist: MC 450
--	---	---

(\*) For greater heights, ask to manufacturer.

## SAFETY DEVICES INCLUDED AND OPTIONS

	INCLUDED	OPTION
<b>GENERALS</b>		
Gearmotor with electromechanical brake	✓	
Overspeed parachute with auto-recovery system	✓	
Emergency lowering lever	✓	
Cage doors with automatic side protection	✓	
Landing doors with mechanical / electrical interlock		✓
Base enclosure with electrical interlock		✓
Hoist control display with signaling LEDs:	✓	
- Cage door open		
- Landing door open		
- Enf of mast		
- Upper/lower endtrack		
- Aux. Crane interfering		
- Last 2 m zone		
- Overspeed parachute		
- Cage overload		
- Motor overheat fault		
- Hoist free / busy		
Automatic floor management	✓	
Buffers at the ground base	✓	
Hoist control CPU, with event log	✓	
Upper/lower endtrack limit switch	✓	
Safety endtrack limit switch	✓	
Overload detection device	✓	
Mast presence switch	✓	
Last mast without rack	✓	
Motor with brake wear signal		✓
Cage floor of non-slipping galvanized steel	✓	
Movement warning horn (LAST 2 m)	✓	PT-450-2V
Phase control	✓	
Emergency stop	✓	
Landing levels call system		✓
Parachute test remote control		✓
Automatic greaser		✓

# PT 1200

## IDEAL FOR MEDIUM CONSTRUCTIONS AND GREAT REHABILITATIONS

This model is also available in a specific version to transport drywall (the PT 1000F version).

It is lifted by the triangle mast, compatible with the EPM 1000 passengers and material hoist, the MC 1000 material hoist and the PEC 120 mast climber.

### Main features:

- **Load capacity:** 1200 kg.
- **Cabin maximum dimensions:** 2,5 x 1,4 x 2,1 m (PT 1200) or 2,5 x 1,4 x 2,1 m (PT 1000F).
- **Maximum speed:** 20 m/min.
- **Maximum height:** 120 m (ask us for greater heights).



## DATA SHEET PT 1200

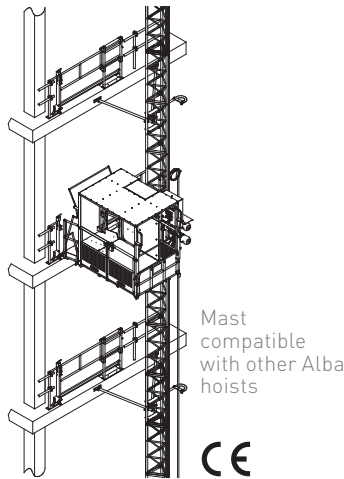

CPU and automatic floor management



Overspeed parachute with auto-recovery system



Landing levels call system



Folding ramps with automatic side protection

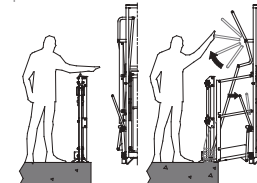

Installation dimensions

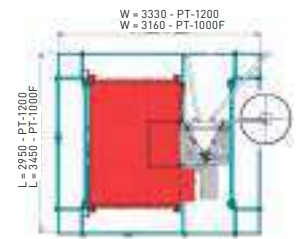

Dual operation mode: persons - loads



### TECHNICAL FEATURES

	PT 1200-2V	PT 1000F-2V	PT 1200-1V	PT 1000F-1V
Maximum capacity	7 pax + 500 kg 1.200 kg	7 pax + 300 kg 1.000 kg	12 pax 1.200 kg	10 pax 1.000 kg
Cage dimensions (LxWxH)	2 x 1,4 x 2,1 m	2,5 x 1,4 x 2,1 m	2 x 1,4 x 2,1 m	2,5 x 1,4 x 2,1 m
Vertical speed	12+20 m/min		20 m/min	
Motor power	2 x 3 kW		2 x 3 kW (50 Hz) 2 x 3,6 kW (60 Hz)	
Motor control	FREQUENCY CONVERTER		DIRECT	
Maximum height (*)	120 m (*)			
Anchorage each (max.)	6 m			
Height over last anchorage	1,5 m			
First anchorage height	6 m			
Loading height-to-ground	400 mm			
Maximum load (assembly)	300 kg			
Noise emission value	<70 dB			
Regulations reference	EN-16719		EN-12158	

### ELECTRICAL DATA

	PT 1200/1000F-2V		PT 1200/1000F-1V	
	50 Hz	50 Hz	50 Hz	60 Hz
Motor power	2 x 3 kW	2 x 3 kW	2 x 3 kW	2 x 3,6 kW
Input power connection	380÷460 V – 50/60Hz.	400 V – 50Hz	440 V – 60Hz	380 V – 60Hz
Power consumption	7,5 kW	6 kW	6 kW	7,2 kW
Nominal current	17 A	14 A	14 A	15 A // 17 A
Supply power	20 kVA			
Starting current	-	70 A	70 A	83 A 97 A
Overload protection	3 x 25 A			
Differential protection Calibration Sensitivity	25 A 300 mA			
Control voltage	48 V			
Auxiliar handtools socket	230 V – 50/60 Hz 1200W			
Cable section	4 x 6 mm <sup>2</sup>			

#### MAST SECTION

**Triangle mast**  
Length: 1,5 m  
Weight: 47 kg

**Mast compatibility:** (see p.50)  
Mast climber: PEC 120  
Material hoist: MC 1000  
Passengers & material hoist: EPM 1000

(\*) For greater heights, ask to manufacturer.

In our constant improving, we reserve the right to make modifications. The images in this catalogue are merely illustrative and in no case contractual.

### SAFETY DEVICES INCLUDED AND OPTIONS

	INCLUDED	OPTION
<b>GENERALS</b>		
Gearmotors with electromechanical brake	✓	
Overspeed parachute with auto-recovery system	✓	
Emergency lowering lever	✓	
Cage doors with automatic side protection	✓	
Landing doors with mechanical / electrical interlock		✓
Base enclosure with electrical interlock		✓
Hoist control display with signaling LEDs:	✓	
- Cage / landing door open		
- End of mast		
- Upper/lower endtrack		
- Aux. Crane interfering		
- Fault on brake of motor		
- Last 2 m. Zone		
- Overspeed parachute		
- Cage overload		
- Motor overheat fault		
- Hoist free / busy		
Automatic floor management	✓	
Buffers at the ground base	✓	
Hoist control CPU, with event log	✓	
Upper/lower endtrack limit switch	✓	
Safety endtrack limit switch	✓	
Overload detection device	✓	
Mast presence switch	✓	
Last mast without rack	✓	
Aux. catwalk for anchorage assembly	✓	
Aux. crane for mast assembly		✓
Motors with brake wear signal		✓
Cage floor of non-slipping galvanized steel	✓	
Movement warning horn (LAST 2 m)	✓	PT-2V
Phase control	✓	
Emergency stop	✓	
Landing levels call system		✓
Parachute test remote control		✓
Automatic greaser		✓

# PT 1800

## GREAT LIFTING CAPACITY IN LARGE SURFACES

This platform allows to transport up to 20 passengers or 7 passengers with material and equipment; especially suitable for lifting drywall. Thanks to the robustness of the square mast by which it rises, the PT 1800 can work together with the EDC 2000 and MC 2000 hoists at the same time.

### Main features:

- **Load capacity:** 1800 kg.
- **Cabin maximum dimensions:** 3,3 x 1,4 x 2,1 m.
- **Maximum speed:** 22 m/min.
- **Maximum height:** 250 m (ask us for greater heights).
- Possibility of incorporating a third loading door.



# DATA SHEET PT 1800

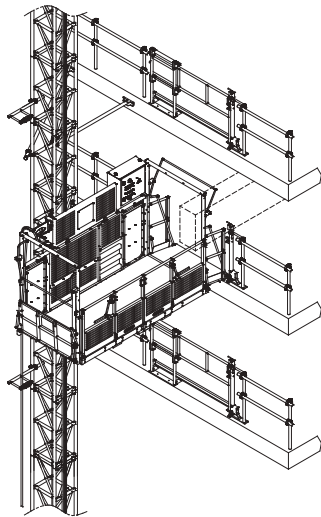

Mast compatible with other Alba hoists



Falling object protection guard - removable

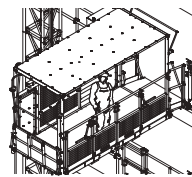

CPU and automatic floor management



Installation dimensions

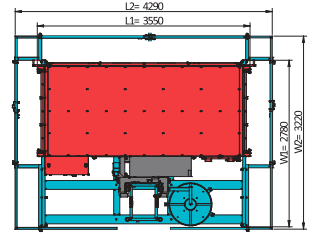

Overspeed parachute with auto-recovery system



Folding ramps with automatic side protection

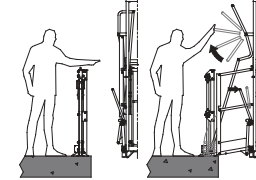

Dual operation mode: persons - loads



## TECHNICAL FEATURES

	PT 1800FA-2V	PT 1800FB-2V	PT 1800FA-1V	PT 1800FB-1V
Maximum capacity	12 ÷ 22 m/min		20 m/min	
Vertical speed	7 pax + 1.100 kg 1.800 kg		20 pax 1.800 kg	
Cage dimensions (LxWxH)	3,3 x 1,4 x 2,1 m		3,3 x 1,4 x 2,1 m	
Motor control	FREQUENCY CONVERTER		DIRECT	
Maximum height (*)	250 m (*)			
Anchorage each (max.)	9 m			
Height over last anchorage	3 m			
First anchorage height	6 m			
Loading height-to-ground with cable bin with cable trolley	500 mm 800 mm			
Maximum load (assembly)	500 kg			
Regulations reference	EN-16719 ; 2006/42/CE		EN-12158	

## ELECTRICAL DATA

	PT 1800F-2V	PT 1800F-1V	
	50/60 Hz	50 Hz	60 Hz
Motor power	2 x 5,5 kW	2 x 5,5 kW	2 x 6,6 kW
Input power connection	380÷460 V - 50/60Hz	400 V - 50Hz	440 V - 60Hz
Power consumption	15 kW	11 kW	
Nominal current	32 A	25 A	
Supply power	30 kVA	20 kVA	
Overload protection	3 x 32 A		
Differential protection Calibration Sensitivity	32 A 300 mA		
Control voltage	48 V		
Auxiliar handtools socket	230 V - 50/60 Hz 1200 W		
Cable section	4 x 10 mm <sup>2</sup>		

<b>MAST SECTION</b> 	<b>Square mast</b> Length: 1,5 m Weight: 1Rack: 98 kg 2Rack: 118 kg	<b>Mast compatibility: (see p.50)</b> Mast climber: PEC 130 / PEC 150 Material hoist: MC 2000 Passengers & material hoist: EDC 1700/2000 Transport platform: PTB 3800
-------------------------	---	---

(\*) For greater heights, ask to manufacturer.

## SAFETY DEVICES INCLUDED AND OPTIONS

	INCLUDED	OPTION
<b>GENERALS</b>		
Gearmotors with electromechanical brake	✓	
Overspeed parachute with auto-recovery system	✓	
Emergency lowering lever	✓	
Cage doors with automatic side protection	✓	
Landing doors with mechanical / electrical interlock		✓
Base enclosure with electrical interlock		✓
Hoist control display with signaling LEDs:	✓	
- Cage / landing door open		
- End of mast		
- Upper/lower endtrack		
- Aux. Crane interfering		
- Fault on brake of motor		
- Last 2 m zone		
- Overspeed parachute		
- Cage overload		
- Motor overheat fault		
- Hoist free / busy		
Automatic floor management	✓	
Buffers at the ground base	✓	
Falling object protection guard	✓	
Hoist control CPU, with event log	✓	
Upper/lower endtrack limit switch	✓	
Safety endtrack limit switch	✓	
Overload detection device	✓	
Mast presence switch	✓	
Last mast without rack	✓	
Aux. platform for mast and anchorage assembly	✓	
Aux. crane for mast assembly		✓
Motors with brake wear signal		✓
Cage floor of non-slipping galvanized steel	✓	
Movement warning horn (LAST 2 m)	✓	PT-2V
Phase control	✓	
Emergency stop	✓	
Landing levels call system		✓
Parachute test remote control		✓
Automatic greaser		✓

# PTB 3800

## OPTIMAL SOLUTION FOR TRANSPORTING GREAT LOAD VOLUMES FOR CONSTRUCTION

The PTB 3800 hoist is made up of a wide and versatile platform with 2 masts that work by means of a cardan system transmission.

This model presents new features that respond to market needs, such as a larger space specially designed to lift prefabricated structures and great equipment, achieving a faster and cheaper construction process.

### Main features:

- **Great load capacity:** 3800 kg.
- **Maximum speed:** 20 m/min.
- **Maximum height:** 250 m (ask us for greater heights).
- Configurable with different cabin sizes up to 5,3 x 3,2 m.
- Suitable for lifting prefabricated structures (kitchens, complete bathrooms, etc.).
- One of the PTB 3800's square masts can be used by another hoist simultaneously: the EDC 2000, the PT 1800 or the MC 2000.





# EPM 1000

## COMPACT AND WITH GREAT LOAD CAPACITY

Easy to install, this hoist is suitable for confined spaces. It presents optimal quality at an unbeatable price, as it is more compact than the EDC 2000 and rises through a triangle mast. Its call control system between floors gives it high performance. In addition, we offer a version for lifting drywall with a slightly longer cabin.

### Main features:

- **Load capacity:** 1000 kg.
- **Cabin dimensions:** 2000 x 1400 x 2100 mm.
- **Maximum speed:** 20 m/min.
- **Maximum height:** 120 m  
(ask us for greater heights).



# DATA SHEET EPM 1000

## Installation dimensions

CPU and automatic floor management

Landing levels call system

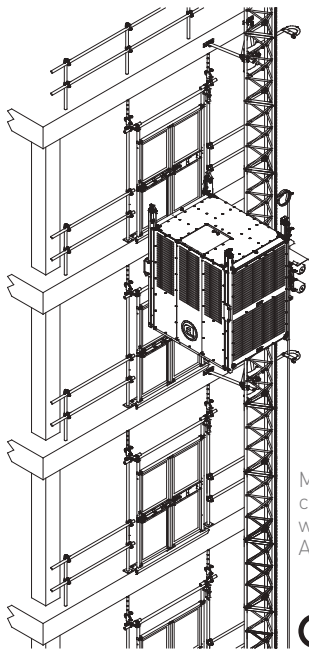

Mast compatible with other Alba hoists

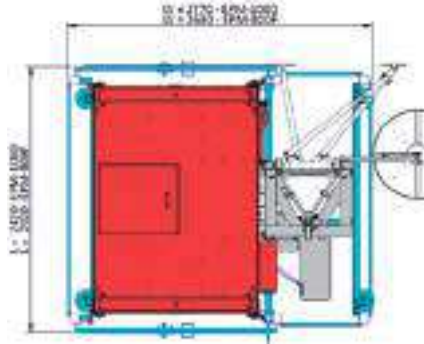

Overspeed parachute with auto-recovery system



Auxiliar catwalk for anchorage assembly



## SAFETY DEVICES INCLUDED AND OPTIONS

INCLUDED OPTION

### GENERALS

Gearmotors with electromechanical brake	✓
Overspeed parachute, with auto-recovery system	✓
Emergency lowering lever	✓
Cage doors with mechanical / electrical interlock	✓
Landing doors with mechanical / electrical interlock	✓
Base enclosure according to EN-12159	✓
Hoist control display with signaling LEDs:	✓
- Cage door open	
- Landing door open	
- End of mast	
- Upper/lower endtrack	
- Aux. Crane interfering	
- Last 2 m Zone	
- Overspeed parachute	
- Cage overload	
- Motor overheat fault	
- Hoist free / busy	
Automatic floor management	✓
Buffers at the ground base	✓
Hoist control CPU, with event log	✓
Upper/lower endtrack limit switch	✓
Safety endtrack limit switches	✓
Overload detection device	✓
Mast presence switch	✓
Last mast without rack	✓
Aux. catwalk for anchorage assembly	✓
Aux. crane for mast assembly	✓
Motors with brake wear signal	✓
Cage floor of non-slipping galvanized steel	✓
Movement warning horn	✓
Phase control	✓
Emergency stop	✓
Emergency exit, accessible roof with safety railing	✓
Landing levels call system	✓
Parachute test remote control and mast assembly	✓
Operator aux. external cage	✓
Automatic greaser	✓

## TECHNICAL FEATURES

	EPM 1000	EPM 1000V	EPM 800F	EPM 800FV
Motor control	DIRECT	FREQ. CONVERTER	DIRECT	FREQ. CONVERTER
Vertical speed	20 m/min	33 m/min	20 m/min	33 m/min
Maximum capacity	1.000 kg 12 pax.		800 kg 10 pax.	
Cage dimensions (LxWxH)	2.000 x 1.400 x 2.100 mm		2.500 x 1.400 x 2.100 mm	
Maximum height (*)	120 m (*)			
Anchorage each (max.)	6 m			
Height over last anchorage	1,5 m			
First anchorage height	6 m			
Loading height-to-ground	400 mm			
Maximum load (assembly)	300 kg			
Noise emission value	<70 dB			
Regulations reference	EN-12159 ; 2006/42/CE			

## ELECTRICAL DATA

	EPM 1000 EPM 800F	EPM 1000V EPM 800FV
Motor power	2 x 3 kW (50Hz) 2 x 3,6 kW (60Hz)	
Input power connection	400 V - 50Hz 440 V - 60Hz	380 ÷ 460 V - 50/60Hz
Power consumption	7 kW	15 kW
Nominal current	15 A	30 A
Supply power	20 kVA	30 kVA
Overload protection	4 x 25 A	4 x 40 A
Differential protection Calibration Sensitivity	25 A 300 mA	40 A 300 mA
Control voltage	48 V	
Auxiliar handtools socket	230 V - 50/60 Hz 1200 W	
Cable section	4 x 6 mm <sup>2</sup>	

### MAST SECTION



**Triangle mast**  
Length: 1,5 m  
Weight: 47 kg

**Mast compatibility:** (see p.50)  
Mast climber: PEC 120  
Material hoist: MC 1000  
Transport platform: PT 1200

(\*) For greater heights, ask to manufacturer.

# EDC 2000

## THE BEST TRANSPORT SOLUTION FOR THE CONSTRUCTION OF GREAT HEIGHT BUILDINGS

The EDC 2000 is designed to lift passengers and materials up to 2000 kg and it has an advanced technology capable of storing information for the automatic selection of floors.

Available in double cab, the EDC 2000 is raised by a square mast, which gives it great stability and it can work simultaneously with other passengers and materials hoists (the PT 1800 and the PTB 3800 transport platforms and the MC 2000 material hoist). This mast is also compatible with the PEC 130 and 150 work platforms.

### Main features:

- **Load capacity:** 2000 kg.
- **Cabin dimensions:** 3200 x 1400 x 2100 mm.
- **Maximum speed:** 60 m/min.
- **Maximum height:** 250 m (ask us for greater heights).
- Hoist control CPU and automatic selection of floors.
- Failure diagnostic LED display.



We have several versions of this model:

#### **EDC 1700**

With all the features of the EDC 2000, we offer this version with the same cabin dimensions, but with a load limitation of 1.700 kg, which makes it lift at 20 m/min.

#### **EDC 2000 ECO**

For this version, we have created a simpler and more intuitive operation and configuration via joystick to offer a hoist with the same load capacity but at a lower price. Frequency converter motor start control.

#### **EDC XL**

The EDC XL is designed to lift bulky elements, such as gypsum boards, meeting the needs of the market that demands solutions for large dimensions. Side door width: 3700 x 1500 x 2100 mm.



# DATA SHEET EDC 1700/2000

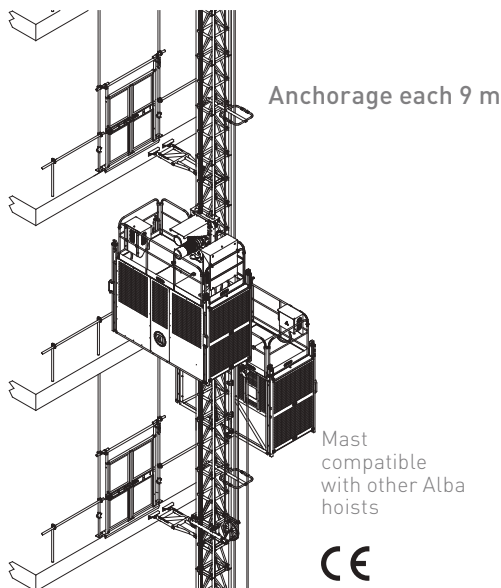

Installation dimensions

Single cage



Twin cage



Single or twin cage

CPU and automatic floor management



Overspeed parachute with auto-recovery system



Landing levels call system



## SAFETY DEVICES INCLUDED AND OPTIONS

	INCLUDED	OPTION
<b>GENERALS</b>		
Gearmotors with electromechanical brake	✓	
Overspeed parachute, with auto-recovery system	✓	
Emergency lowering lever	✓	
Cage doors with mechanical / electrical interlock	✓	
Landing doors with mechanical / electrical interlock		✓
Base enclosure according to EN-12159		✓
Hoist control display with signaling LEDs:	✓	
- Cage / landing door open		
- End of mast		
- Upper/lower endtrack		
- Aux. Crane interfering		
- Fault on brake of motor		
- Last 2 m zone		
- Overspeed parachute		
- Cage overload		
- Motor overheat fault		
- Hoist free / busy		
Buffers at the ground base	✓	
Hoist control CPU, with event log	✓	
Encoder based positioning system	✓	
Upper/lower endtrack limit switch	✓	
Safety endtrack limit switch	✓	
Overload detection device	✓	
Mast presence switch	✓	
Last mast without rack	✓	
Aux. crane for mast assembly		✓
Frecuency converter motor start control	✓	EDC 2000
Bi-metal PTC thermal probe	✓	EDC 2000
Motors with brake wear signal		✓
Cage floor of non-slipping galvanized steel	✓	
Movement warning horn	✓	
Phase control	✓	
Emergency stop	✓	
Emergency exit, accessible roof with safety railing	✓	
Landing levels call system		✓
Parachute test remote control		✓
Operator aux. external cage		✓
Add-on platform for anchorage assembly		✓
Automatic greaser		✓

## TECHNICAL FEATURES

	EDC 1700-20	EDC 2000-40	EDC 2000-60
Maximum capacity	20 pax / 1.700 kg	20 pax / 2.000 kg	
Vertical speed	20 m/min	40 m/min	60 m/min
Cage dimensions (LxWxH)	3.200 x 1.400 x 2.100 mm		
Motor power	2 x 5,5 kW [50 Hz] 2 x 6,6 kW [60 Hz]	2 x 11 kW	
Motor control	DIRECT	FREQUENCY CONVERTER	
Control mode	Automatic or Hold-to-run		
Maximum height (*)	250 m (*)		
Anchorage each (max.)	9 m		
Height over last anchorage	3 m		
First anchorage height	6 m		
Loading height-to-ground with cable bin with cable trolley	400 mm 700 mm		
Maximum load (assembly)	500 kg		
Noise emission value	<70 dB		
Regulations reference	EN-12159 ; 2006/42/CE		

## ELECTRICAL DATA

	EDC 1700-20	EDC 2000-40	EDC 2000-60
Motor power	2 x 5,5 kW [50 Hz] 2 x 6,6 kW [60 Hz]	2 x 11 kW	
Input power connection	400 V - 50 Hz 440 V - 60 Hz	380 ÷ 460V - 50/60 Hz	
Power consumption	11 kW	30 kW	45 kW
Nominal current	25 A	50 A	90 A
Supply power	20 kVA	50 kVA	75 kVA
Starting current	32 A	63 A	125 A
Overload protection	3 x 32 A	3 x 63 A	3 x 125 A
Differential protection Calibration Sensitivity	32 A 300 mA	63 A 300 mA	125 A 300 mA
Control voltage	48 V		
Auxiliar handtools socket	230 V - 50/60 Hz 1200 W		
Cable section	4 x 10 mm <sup>2</sup>	4 x 16 mm <sup>2</sup>	4 x 25 mm <sup>2</sup>

### MAST SECTION

**Square mast**  
Length: 1,5 m  
Weight:  
1Rack: 98 kg  
2Rack: 118 kg

**Mast compatibility: (see p.50)**  
Mast climbers:  
PEC 130 / PEC 150  
Material hoist: MC 2000  
Transport platform: PT 1800 / PTB 3800

(\*) For greater heights, ask to manufacturer.

# DATA SHEET EDC 2000 ECO

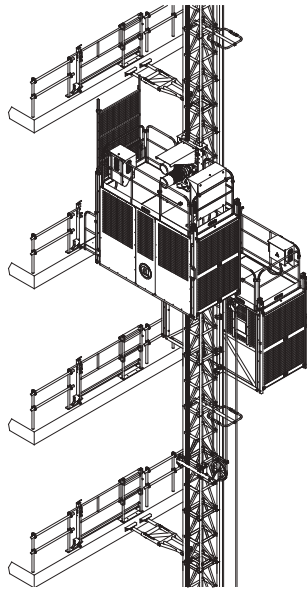

Mast compatible with other Alba hoists

## Installation dimensions

### Single cage

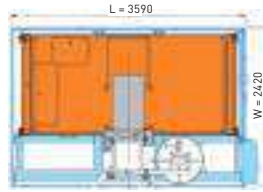

### Twin cage



## Single or twin cage



Overspeed parachute with auto-recovery system



## Control panel intuitive & easy to use



Landing doors of complete or reduced height



## SAFETY DEVICES INCLUDED AND OPTIONS

INCLUDED OPTION

### GENERALS

Gearmotors with electromechanical brake	✓
Overspeed parachute, with auto-recovery system	✓
Emergency lowering lever	✓
Cage doors with mechanical / electrical interlock	✓
Landing doors with mechanical / electrical interlock	✓
Base enclosure according to EN-12159	✓
Red LED indicator of power service	✓
Yellow LED indicator of safety devices	✓
Buffers at the ground base	✓
Upper/lower endtrack limit switch	✓
Safety endtrack limit switch	✓
Overload detection device	✓
Mast presence switch	✓
Last mast without rack	✓
Aux. crane for mast assembly	✓
Motors with brake wear signal	✓
Cage floor of non-slipping galvanized steel	✓
Movement warning horn	✓
Phase control	✓
Emergency stop	✓
Emergency exit, accessible roof with safety railing	✓
Parachute test remote control	✓
Operator aux. external cage	✓
Add-on platform for anchorage assembly	✓
Automatic greaser	✓

## TECHNICAL FEATURES

	EDC 2000ECO
Maximum capacity	20 pax / 2.000 kg
Vertical speed	0 - 36 m/min
Cage dimensions (LxWxH)	3.200 x 1.400 x 2.100 mm
Motor power	2 x 11 kW
Motor control	FREQUENCY CONVERTER
Maximum height (*)	250 m (*)
Anchorage each (max.)	9 m
Height over last anchorage	3 m
First anchorage height	6 m
Loading height-to-ground with cable bin	400 mm
with cable trolley	700 mm
Maximum load (assembly)	500 kg
Noise emission value	<70 dB
Regulations reference	EN-12159 ; 2006/42/CE

## ELECTRICAL DATA

	EDC 2000ECO
Motor power	2 x 11 kW
Input power connection	380 ÷ 460 V - 50/60 Hz
Power consumption	30 kW
Nominal current	50 A
Supply power	50 kVA
Starting current	63 A
Overload protection	3 x 63 A
Differential protection	
Calibration	63 A
Sensitivity	300 mA
Control voltage	48 V
Auxiliar handtools socket	230 V - 50/60 Hz - 1.200 W
Cable section	3 x 16 mm <sup>2</sup> + PE

### MAST SECTION



**Square mast**  
Length: 1,5 m  
Weight:  
1Rack: 98 kg  
2Rack: 118 kg

**Mast compatibility: (see p.50)**  
Mast climbers:  
PEC 130 / PEC 150  
Material hoist: MC 2000  
Transport platform: PT 1800 / PTB 3800

(\*) For greater heights, ask to manufacturer.

# PMH

## HIGHER PERFORMANCE GREAT LOAD CAPACITY

The PMH is suitable for large-scale buildings. With a capacity of 3.200 kg, it is available in several cabin sizes and has advanced technology with remote connection for management and diagnosis.

To double its capacity, an additional cabin can be installed on the same 650 square mast. It is a model created specifically for this hoist, compatible with other brands equipment.

### Main features:

- **Maximum load capacity:** 3200 kg.
- **Cabin dimensions:** 4500 x 1150 x 2400 mm.
- **Maximum speed:** 80 m/min.
- **Maximum height:** 350 m (ask us for greater heights).
- Possibility of incorporating a lateral loading door.



# DATA SHEET PMH

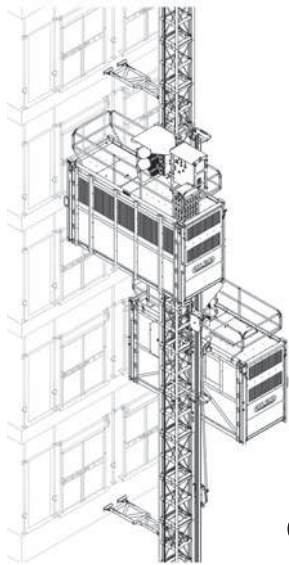

Installation dimensions

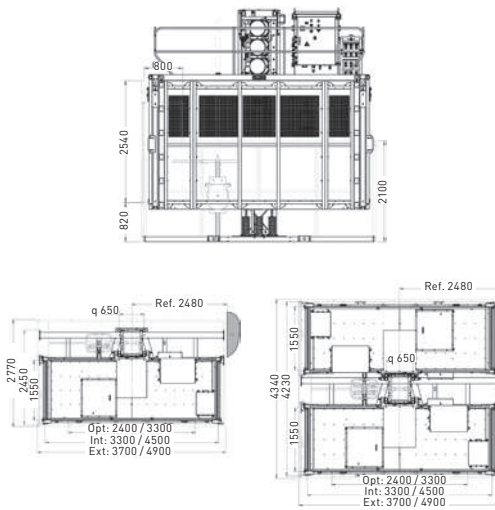

Lateral loading "C" door (option)  
PLC and automatic or hold to run control



Remote connection for hoist management



Overspeed parachute with auto-recovery

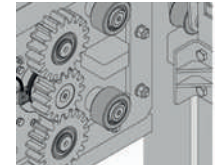

## TECHNICAL FEATURES

	PMH 2033-40 PMH 2033-80	PMH 3233-40 PMH 3233-80	PMH 1545-40 PMH 1545-80	PMH 2745-40 PMH 2745-80
<b>Maximum load capacity</b>	2000 kg 25 pax	3200 kg 25 pax	1500 kg 18 pax	2700 kg 33 pax
<b>Cabin dimensions (LxWxH)</b>	3300 x 1550 x 2400 mm		4500 x 1550 x 2400 mm	
<b>Vertical speed</b>	40 m/min 80 m/min			
<b>Motor control</b>	FREQUENCY CONVERTER			
<b>Control mode</b>	AUTOMATIC OR HOLD-TO-RUN			
<b>Maximum height (*)</b>	350 m (*)			
<b>Max. mast tie spacing</b>	12 m			
<b>Max. mast overhang</b>	Max.: 9 m			
<b>Loading height-to-ground</b>	820 mm			
<b>Noise emission value</b>	<70 dB			
<b>Regulations references</b>	EN-12159; 2006/42/CE			

## ELECTRICAL DATA

	PMH 2033-40 PMH 1545-40	PMH 3233-40 PMH 2745-40	PMH 2033-80 PMH 1545-80	PMH 3233-80 PMH 2745-80
<b>Motor power</b>	2 x 15 kW	3 x 15 kW	2 x 15 kW	3 x 15 kW
<b>Input power connection</b>	380÷480 V – 60 Hz.			
<b>Power consumption</b>	37 kW	55 kW	75 kW	130 kW
<b>Nominal current</b>	60 A	95 A	105 A	156 A
<b>Supply power</b>	50 kVA	75 kVA	100 kVA	200 kVA
<b>Supply current (400V)</b>	75 A	110 A	150 A	190 A
<b>Overload protection</b>	3 x 100 A	3 x 125 A	3 x 175 A	3 x 225 A
<b>Differential protection Calibration Sensitivity</b>	100 A 300 mA	125 A 300 mA	175 A 300 mA	225 A 300 mA
<b>Control voltage</b>	48 V			
<b>Auxiliar handtools socket</b>	230 V – 50/60 Hz 1200 W			
<b>Cable section</b>	4 x 16 mm <sup>2</sup>	4 x 25 mm <sup>2</sup>	4 x 35 mm <sup>2</sup>	4 x 50 mm <sup>2</sup>

<b>MAST SECTION</b>	<b>M650 Mast</b> Length: 1,5 m Weight: 1 Rack: 140 kg 2 Rack: 165 kg	<b>Galvanized mast:</b> Compatible with other brands equipment.

(\*) For greater heights, ask to manufacturer.

## SAFETY DEVICES INCLUDED AND OPTIONS

	INCLUDED	OPTION
Gearmotors with electromechanical brake	✓	
Overspeed parachute with auto-recovery system	✓	
Emergency lowering lever	✓	
Cage doors with automatic side protection	✓	
Landing doors with mechanical / electrical interlock		✓
Base enclosure according to ANSI A10.4		✓
Control panel with diagnosis display	✓	
Buffers at the ground base	✓	
PLC and automatic floor selection	✓	
Automatic or hold-to-run control	✓	
Encoder based hoist positioning system	✓	
Upper/lower endtrack limit switch	✓	
Safety endtrack limit switch	✓	
Overload detection device	✓	
Mast presence switch	✓	
Last mast without rack	✓	
Aux. crane for mast assembly		✓
Smooth starting with frequency converter	✓	
Thermal protection probe inside motors	✓	
Cage floor of non-slipping steel sheet	✓	
Movement warning horn	✓	
Phase control	✓	
Emergency stop	✓	
Emergency exit, accessible roof with safety railing	✓	
Landing levels calling system with traffic management		✓
Parachute test remote control		✓
Remote connection for hoist management		✓

# EG 250

## EFFICIENCY AND SAFETY WHEN LIFTING THROUGH THE CRANE

With capacity for 2 passengers (250 kg), this lift gives operators the greatest safety and comfort when rising by the crane, since it has a centrifugal brake and overspeed parachute.

Quick and easy to assemble, the EG 250 has a universal anchor for all types of tower cranes every 4,2 m.

### Main features:

- **Load capacity:** 250 kg.
- **Cabin dimensions:** 1200 x 600 x 2050 mm.
- **Maximum speed:** 20 m/min.
- **Maximum height:** 120 m (ask us for greater heights).
- Valid for other applications such as wind mills.



## DATA SHEET EG 250

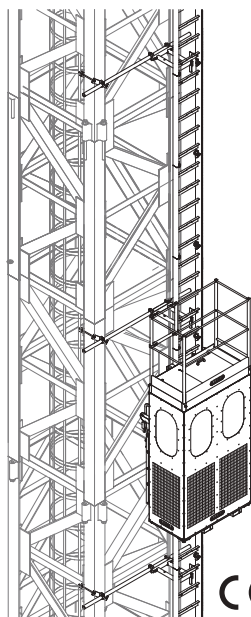

Fast union single-point anchorage for specific crane models

Anchorage compatible with all types of crane

Validating control system and diagnostic LEDs

Installation dimensions

Control to send or call the hoist at access points

Overspeed parachute with auto-recovery system

Additional safety device - centrifugal brake

Interior and exterior control + inspection mode



### TECHNICAL FEATURES

	50 Hz	60 Hz
Maximum capacity	2 pax - 250 kg	
Vertical speed	20 m/min	
Cage dimensions (LxWxH)	1.300 x 600 x 2.050 mm	
Minimum hoistway	□1.500 x 1.500 mm	
Motor power	2 x 1,1 kW	2 x 1,32 kW
Motor control	DIRECT	
Maximum height (*)	120 m(*)	
Anchorage each (max.)	4,2 m	
Minimum load height	300 mm	
Maximum load (assembly)	150 kg	
Noise emission value	<70 dB	
Regulations reference	2006/42/CE ; EN-81-43	

### ELECTRICAL DATA

	50 Hz	60 Hz
Motor power	2 x 1,1 kW	2 x 1,32 kW
Input power connection	400 V - 50Hz	440 V - 60Hz
Power consumption	2,2 kW	2,64 kW
Nominal current	6 A	7 A
Supply power	8 kVA	
Starting current	33 A	38 A
Overload protection	10 A	
Differential protection Calibration Sensitivity	10 A 300 mA	
Control voltage	48 V	
Auxiliar handtools socket	230 V - 50/60 Hz 16 A	
Cable section	5 x 2,5 mm <sup>2</sup>	

**MAST SECTION**



**Ladder mast**  
Length: 1,5 m  
Weight: 25 kg

(\*) For greater heights, ask to manufacturer.

### SAFETY DEVICES INCLUDED AND OPTIONS

	INCLUDED	OPTION
<b>GENERALS</b>		
Gearmotor with electromechanical brake	✓	
Overspeed parachute with auto-recovery system	✓	
Centrifugal brake		✓
Emergency lowering lever	✓	
Cage door with automatic side protection	✓	
Landing doors with electrical / mechanical interlock		✓
Base frame enclosure		✓
Hoist control panel with signaling LEDs	✓	
- Cage / landing door open		
- Overspeed parachute		
- Cage overload		
- Out of service		
Buffers at the ground base	✓	
Upper/lower endtrack limit switch	✓	
Safety endtrack limit switch	✓	
Overload detection device	✓	
Mast presence detector	✓	
Upper endtrack buffers	✓	
Cage floor of non-slipping material	✓	
Phase control	✓	
Emergency stop	✓	
Emergency exit, accessible roof with handrails	✓	
Auxiliary catwalk for anchor assembly		✓
Portable control panel for hoist assembly	✓	
Auxiliary mast carrier for column erection		✓
Control panel at lower access to send or call the hoist	✓	
Control panel at upper access to send or call the hoist		✓



# MASTS COMPATIBILITY BETWEEN HOISTS

All masts are designed and manufactured in our facilities.

---

MAST CLIMBERS

---

TRANSPORT PLATFORMS

---

PASSENGERS & MATERIAL HOISTS

---

MATERIAL HOISTS



-

-

PEC 90

PEC 120

PEC 130 / PEC 150

-

-

-

PT 450

PT 1200

PT 1800 / PTB 3800

-

EG 250

-

-

EPM 1000

EDC 1700 / EDC 2000

PMH

-

MC 250

MC 450

MC 1000

MC 2000

-



# MORE THAN 60 YEARS EXPERIENCE

We design, manufacture and commercialise machinery for construction since 1957.



**2004**

Alba becomes the first manufacturer of collective protection system to research on damages with dummies and starts up the first Work Platform overload device, becoming a worldwide pioneer. Two years later, the company is renamed Alba-Macrel Group.

**1998**

A new company is created: Macrel. It is dedicated to a modern manufacturing line: the rack and pinion hoists. Macrel becomes the first European manufacturer to pass AENOR type EC Examinations for its rack and pinion platform.

**1957**

Alba is born in Huertas de la Villa (Bilbao, Bizkaia). The blue colour is chosen as a sign of identity.



**2022**

Alba-Macrel Group keeps innovating to adapt itself to the technological evolution in the industrial area.

**2000**

Macrel starts working this new line from its modern facilities in Miranda de Ebro (Burgos).

**1963**

Alba moves to Sondika (Bizkaia), in order to manage greater projects.

## "BLUE ALBA"

The **color blue** - new for the time - is chosen as a hallmark that will always accompany us. Until then, construction machines were green. At Alba we were the pioneers in that color choice.

## OWN MANUFACTURING AND GREAT ADAPTABILITY

With **more than 22.500 m<sup>2</sup>** of facilities located In Miranda de Ebro (Burgos, Spain) and Sondika (Bizkaia, Spain), we provide top class support, in-house engineering and leading edge technology in design and structural calculation software. Our team works day after day to offer to our customers the most reliable solutions, tailored for each project and specific needs; we guarantee the supply of spare components for machines more than 30 years old.

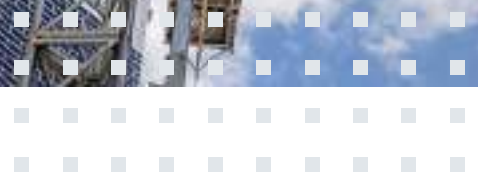

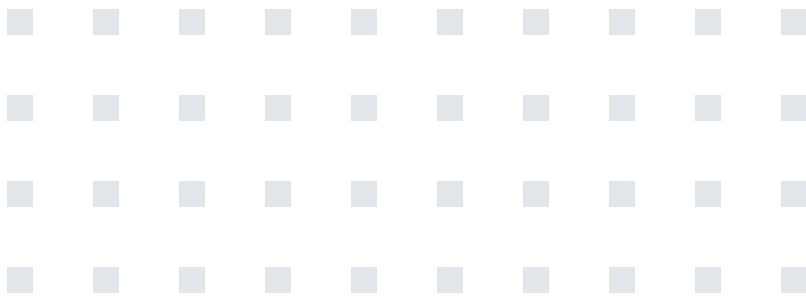

## QUALITY, RELIABILITY AND LEADERSHIP

We offer the best quality in all our products and we provide optimal solutions. Our brilliant track record in workplace accidents ensures **superior safety** quality.

The electronic/electrical components and the motors of all our hoists are manufactured by European-based International brands, also available in North America, complying with all regulations.

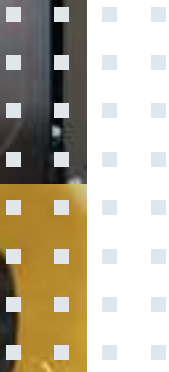



## SUSTAINABILITY

We manufacture the parts in our machining workshops and laser cutting centers, our main objective being the **optimization of raw materials** to try to accomplish minimum residue. We also have a type A energy efficient compressor room, migrating to a more sustainable and lower consumption LED technology. We recycle the materials and generated residues, and we send all our products in wooden or cardboard packaging.



## INTERNATIONAL PRESENCE

We have an Export Department and an After-Sale Service created expressly for the international market and adapted to the needs it demands. Throughout our entire trajectory, we have participated (and continue to participate) in the main international trade fairs, which allows us to learn about the trends in the sector. Our experience makes us today a world-class company, with a **presence in 77 countries**.

Our facilities are located in strategic areas close to the main transport networks, connected worldwide. This allows us, together with proper logistics, that all products arrive in perfect condition at their destination.

## AFTER-SALE SERVICE

We offer a support and maintenance service of all our machines, both in the factory and in our network of Technical Services. Even if some of them ensure a useful life of 40 years, **we guarantee the supply of spare parts and an optimal after-sale service**. All ALBA equipment comes with a specific spare parts breakdown that facilitates the identification of the necessary pieces.



## BUILDING THE FUTURE

At ALBA we continue to innovate within our sector, developing new products and optimizing existing technology in order to respond to the needs of our market.





## HOISTING EQUIPMENT CATALOGUE

In our constant improving, we reserve the right to make modifications.  
The images in this catalogue are merely illustrative and in no case contractual.