

MATERIAL HOIST

MC 250

USER GUIDE

- INSTALLATION, USE & MAINTENANCE INSTRUCTIONS
- SPARE PARTS LIST

CE



ENGLISH

COPY

Machine No.:

Year of manufacture:

Electric connection:

KEEP THIS GUIDE FOR FUTURE REFERENCE

CONTENTS

1. DESCRIPTION OF THE MACHINE	3
1.1 Introduction	3
1.2 General information	4
1.3 Technical data and safety systems	5
1.4 Main components.....	7
1.5 Base set parts and safety systems identification	10
1.6 Other installation data.....	10
2. ASSEMBLY OF THE MACHINE.....	11
2.1 Introduction.....	11
2.2 Transport of the hoist	11
2.3 Requirements on installation site. Requirements for ground support	11
2.4 Requirements for the electrical connection	12
2.5 Erection of the hoist	12
· 2.5.1 Placement of the base machine	12
· 2.5.2 Adjusting the spindle and fixing the nose to ground	13
· 2.5.3 Fixing the hoist to the structure	15
· 2.5.4 Mast column erection.....	16
· 2.5.5 First anchorage	17
· 2.5.5.1 First anchorage of the mast (without external anchorage).....	17
· 2.5.5.2 First anchorage L-Type (158.81)	18
· 2.5.5.3 First anchorage H-Type (158.84)	19
· 2.5.6 Erection of the mast column	20
· 2.5.6.1 Erection of the mast column without external anchorage.....	24
· 2.5.6.2 Erection of the mast column with external anchorage	25
· 2.5.7 Reaction forces in the anchors	26
· 2.5.8 Wall anchorages.....	27
· 2.5.8.1 Anchorage without external anchorage (Minimum distance)	27
· 2.5.8.2 Special anchor for mounting the mast column perpendicular to wall (158.8610).....	28
· 2.5.8.3 Anchorage fixed for mounting the mast column parallel to wall (158.8700).....	29
· 2.5.8.4 Extensible anchorage for mounting the mast column parallel to wall (158.8500)	30
· 2.5.9 Cage assembly	31
· 2.5.9.1 Accessible turning cage	34
· 2.5.10 Installing cable holder, cable guides and electric connection.....	36
· 2.5.11 Access protection	37
· 2.5.11.1 Ground level protection.....	37
· 2.5.11.2 Vertical travel protection	37
· 2.5.12 Installing landing doors. Accessible cage.....	38
2.6 Dismantling the hoist.....	40
3. USING THE MACHINE	41
3.1 Introduction.....	41
3.2 Using the pendant hold-to-run control	41
3.3 Emergency lowering	44
3.4 Checking hoist operation before commissioning.....	44
3.5 Forbidden ways of use.....	45

4. SAFETY DEVICE. PARACHUTE FPC-500	46
4.1 Introduction	46
4.2 Features	46
4.3 Installing the parachute	48
4.4 Parachute drop test	49
· 4.4.1 Manufacturer test.....	49
· 4.4.2 Test during use.....	49
· 4.4.3 Actions to take if safety device is activated	51
4.5 Replacement of the parachute	49
5. MAINTENANCE OF THE MACHINE	53
5.1 DAILY Maintenance.....	53
5.2 PERIODIC maintenance schedule	54
5.3 Instructions for troubleshooting.....	60
5.4 Maintenance record	61
6. ELECTRIC DIAGRAM.....	63
6.1 MC 250 single phase.....	63
6.2 MC 250V single phase with inverter.....	67
6.3 MC 250 three phase 400V-50Hz	72
7. SPARE PARTS	76
7.1 900 X 500 cage.....	86
7.2 Scaffold cage	87
7.3 900 X 650 cage.....	88
7.4 Electric spare parts	89
· 7.4.1 MC 250 single phase.....	89
· 7.4.2 MC 250V single phase with inverter	92
· 7.4.2 MC 250 three phase	95
7.5 Wall anchorages	98
TEST CERTIFICATE	
CE DECLARATION OF CONFORMITY	
CTÜV-PARACHUTE CERTIFICATE	

The user's manual must be kept in good condition. This document contains 98 pages.
Canopy brands Europe S.L.U. reserves the right of incorporating contents or modifications at any time with the purpose of improving both the machine and the information available on the same.



Copyright © CANOPY BRANDS Europe S.L.U.
Rev. 1.0: July 2025

1. DESCRIPTION OF THE MACHINE

1.1. Introduction.

Prior to erection and use, all users must read this manual. A thorough reading is recommended for full compliance with safety regulations.

This manual is delivered with the hoist, and its purpose is to give instructions for proper handling during transportation, erection and maintenance, in compliance with the provisions of EU Directive 2006/42/CE on safe machinery. This instruction manual deals with proper use of the machine as well as proper erection and maintenance.

The manufacturer reserves the right to modify the machine for improvements, so that differences may be found in some manual details. In any case, the manufacturer commits to immediately adapt the manual to the improvements.

Responsibility:

CANOPY BRANDS EUROPE, S.L.U., declines any responsibility for damage caused by improper use of the machine as consequence of non-compliance with the provisions of the present Manual. Specifically declines any responsibility for damages derived from:

- Non-compliance with the provisions of this manual.
- Improper use of the machine.
- The use of non-original spare parts mentioned in the applicable section of manual.
- Modifications introduced without express authorisation from the manufacturer.
- Handling by personnel not trained for this purpose.

Only appointed trained personnel may use the machine and only qualified technical personnel acquainted with the machine may operate on any part of the same.

This manual must be available to the user at any time for any type of immediate consultation. In order to maintain it in perfect conditions, keeping always a copy close to the machine is recommended.

In any case, the manual is aimed at knowledge strengthening and as a reminder for the personnel, who must previously be well trained by engineers or supervisors, who at the same time must be very experienced in this machine operation.

1.1. General information.

It's based on the principle of geared motor transmission to a rack and pinion mechanism. Components are modular and easy to install. It is simple to use and safe for facade work or rehabilitation, significantly reducing the erection time and man-hours.

This machine has been designed for temporary installation on site and must be used by skilled authorised personnel. Its main advantage is the ability to connect different building stories for lifting or lowering materials in a fast and safe way. Below, please find the main points to bear in mind prior to erection and use of the machine.

- The hoist is designed for transporting **only loads**. It can be used for transporting materials during building construction, and for hoisting scaffolding components for assembling scaffold structures.
- The machine runs vertically, geared to the mast rack and guided with support rollers.
- Loading and unloading operations must be carried out by **trained personnel**.
- Machine operation must be carried out by **appointed personnel** trained in hoist operation.
- Case of installing accessible cage, and only in that case, for erection, dismantling, maintenance and repair tasks, only **competent and authorised technical personnel**, trained and qualified with practical experience on said operations, are allowed to travel on the hoist, following all the safety indications of user's manual. Transporting persons in other kind of load carrier is forbidden. Case of using the hoist from inside the accessible cage, additional safety requirements are to be taken:
 - Install cage protection barrier, to achieve protection of $h = 1,1$ m.
 - Use portable control panel with cable prolongation Ref: 158.66, from inside the cage. (See Chapter 3.3)
- The machine is designed to anchor at appropriate intervals to a supporting structure, as the slabs of the floors of a building, a metallic structure or similar. ALBA include in this user's manual all the information regarding to reaction forces to the structure and to the base ground. It is the responsibility of the responsible technicians on site, to ensure that, both supporting structure and base ground support transmitted loads.

WARNING SYMBOLS:



WARNING:
IMPORTANT SAFETY INSTRUCTIONS DURING INSTALLATION OR OPERATION IS TO BE ENTERED IN TEXT BOXES LIKE THIS, INCLUDING THE WARNING SIGN.

1.3. Technical data and safety systems

TECHNICAL DATA	
Vertical speed:	20 m/min
Standard carrier.	
Dimensions (LxWxH):	900 x 500 x 900 mm ^(**)
Maximum capacity:	250 Kg
Accessible cage.	
Dimensions (LxWxH):	1300 x 800 x 1100 mm
Maximum capacity:	200 Kg
Carrier for scaffold parts.	
Dimensions (LxWxH):	900 x 500 x 1800 mm
Maximum capacity:	200 Kg
Motor power:	
· Single phase	1,5 kW – 230V-50/60Hz
· Three phases	1,5 kW – 400V-50Hz
Normative reference:	2006/42/CE
Standard maximum height:	30 m. ^(***)
Anchorage each (max.):	3 m
First anchorage (max.):	2 m

(**) Other dimensions, ask the manufacturer.
 (***) For higher installation, ask the manufacturer.

ELECTRICAL DATA		
	Single phase	Three phases
Input power connection:	1~: 230 V – 50Hz	400V-50Hz
Nominal current:	10 A	4 A
Supply power:	5 KVA	5 KVA
Starting capacitor:	160 µF	-
Running capacitor:	70 µF	-
Overload protection:	2 x 16 A	
Differential protection ^(*)		
Calibre:	16 A	
Sensitivity:	300 mA	
Control voltage:	48 V	

(**) Elements required on main feed switchboard

SAFETY DEVICES		
	INCLUDED	OPTION
• GENERAL:		
· Gearmotor with electromechanical brake	✓	
· Overspeed parachute with auto-recovery system	✓	
· Emergency lowering lever	✓	
· LED for fault detection	✓	
· Buffers at the ground base	✓	
· Superior endtrack buffers	✓	
· Superior / Inferior endtrack limit switch	✓	
· Safety endtrack limit switch	✓	
· Mast presence detector	✓	
· Motor with thermal probe	✓	
· Emergency stop	✓	
· Kit for installation of 3 –intermediate stops in mast		✓
· Base frame enclosure		✓

• CAGE ACCESSIBLE:

· Cage door with electrical interlock	✓
· Cage floor of non-slipping material	✓
· 90 ° turning system with electrical interlock	✓
· Landing doors with electrical / mechanical interlock	✓

ACOUSTIC DATA

A-weighted emission sound pressure level, LpAd	<70dB
Place: Operation point	

1.4. Main components.

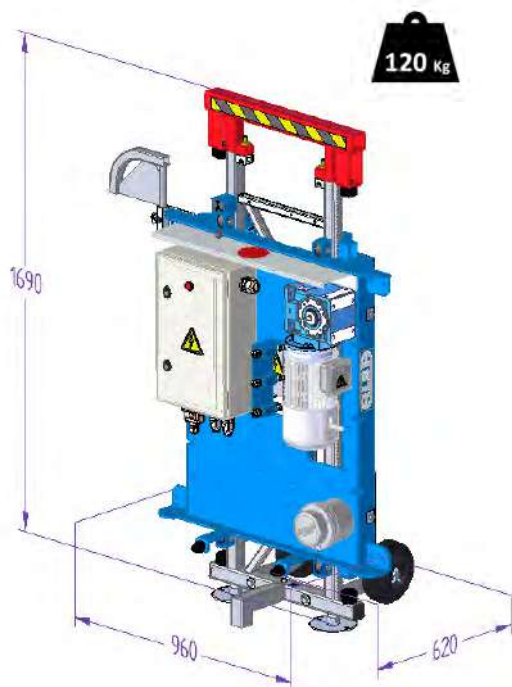

158.0 BASE SET

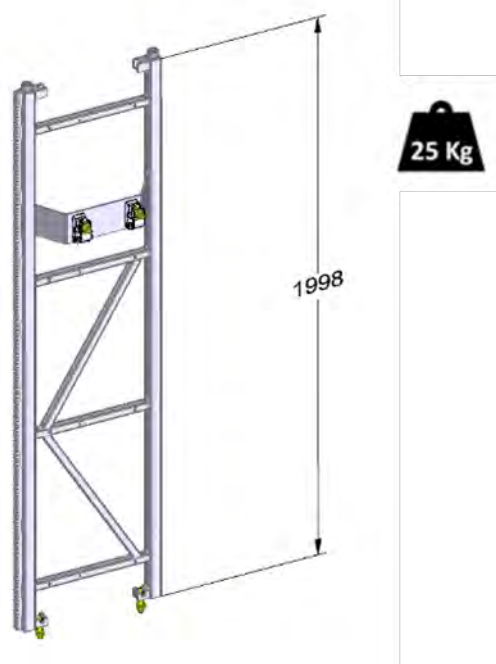

158.92 MASTIL MODULE 2m



158.81 L ANCHOR

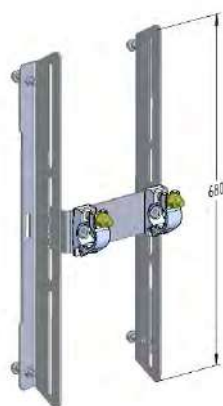

158.82 H ANCHOR



**158.671 CABLE GUIDE
TYPE 1**



**158.672 CABLE GUIDE
TYPE 2**

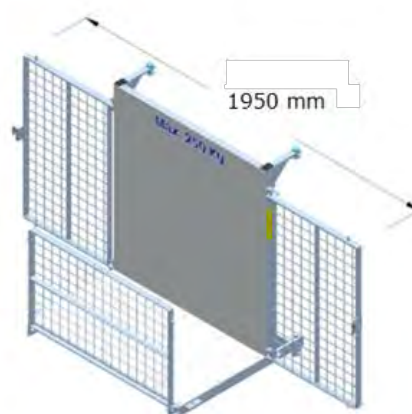
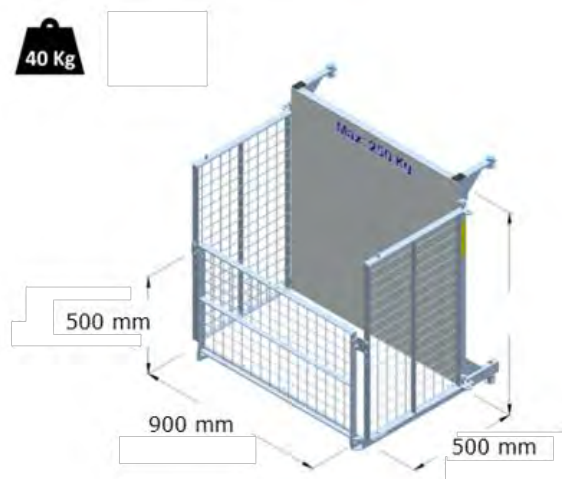

158.41 STANDARD CARRIER 900X500mm

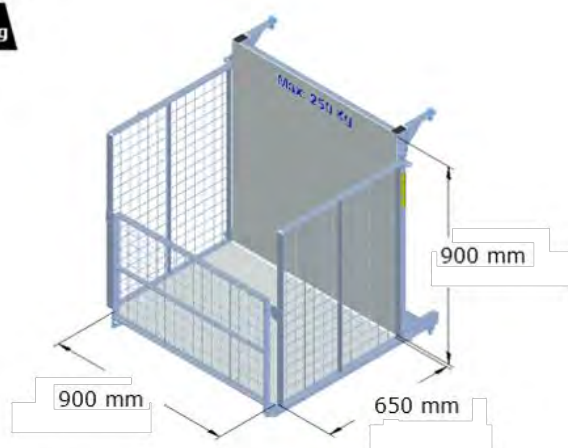

158.46 SPECIAL CARRIER 900x650

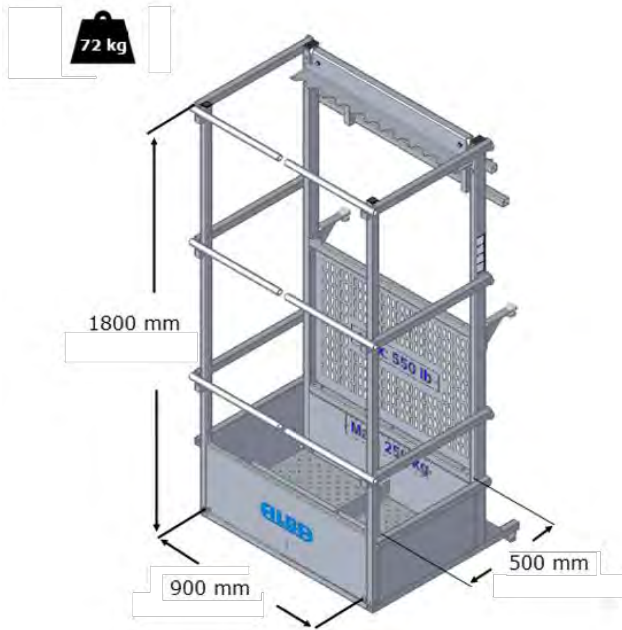
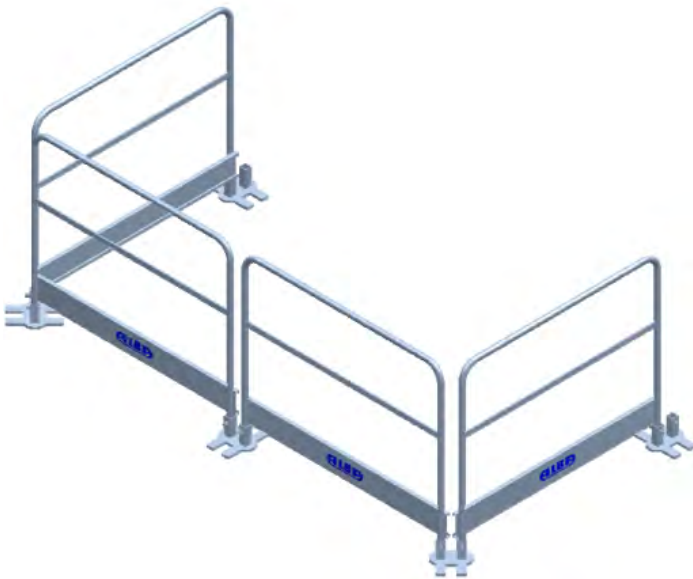

158.40 ACCESIBLE CAGE 1300x800x1100

**158.42 SCAFFOLD CAGE****158.15 BASE PROTECTION**

1.5. Base set parts and safety system identification

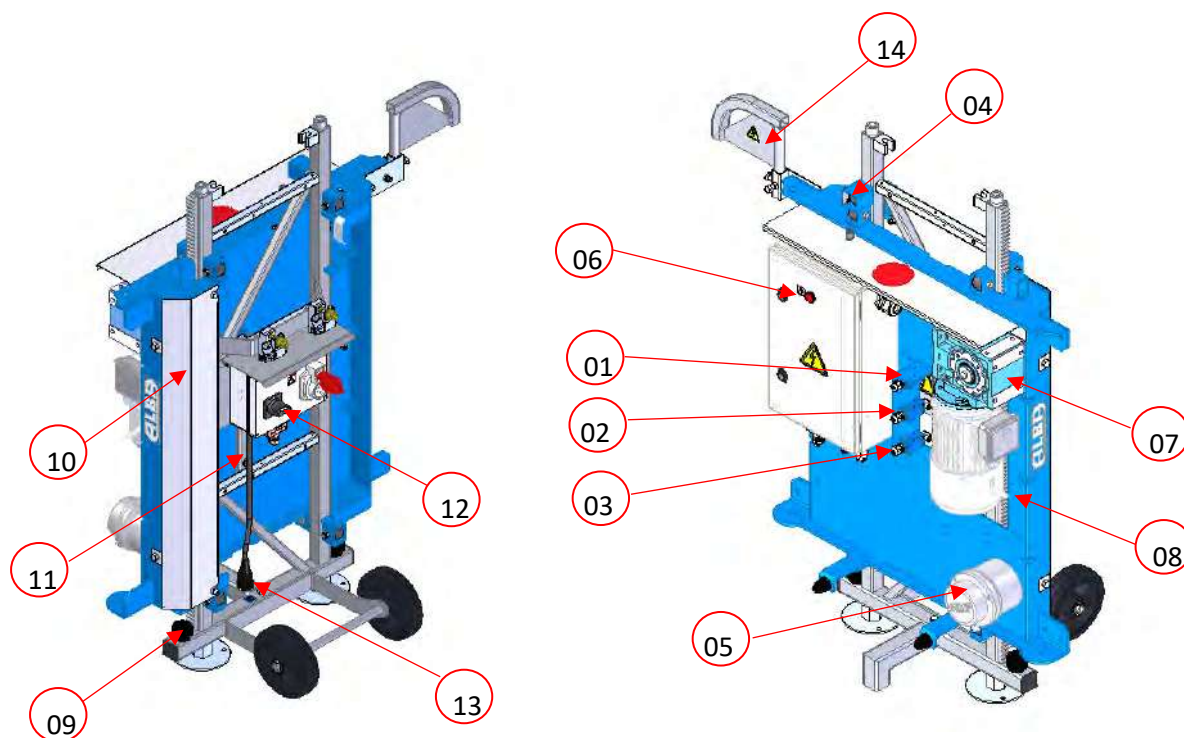

1	Upper endtrack limit switch	8	Emergency descent lever
2	Safety endtrack switch	9	Base buffers
3	Lower endtrack limit switch	10	Pinion protection cover
4	Mast presence detector	11	Lower endtrack limit cam
5	Safety brake parachute	12	General disconnecter switch
6	Out of service red light	13	Electrical supply socket
7	Gearmotor with electromechanic brake	14	Power cable exit guide

1.6. Other installation data

NOISE EMISSION DECLARATION

	Condition
	Outside cage
A-weighted emission sound pressure level, L_{pA}:	71 dB
Uncertainty K_{pA}	3 dB
Values determined according to the acoustic test given in EN 12158-1 with use of basic international standards EN ISO 3744 y EN ISO 4871.	
Note:	
Noise emission values and uncertainty represent un upper limit of the range in which the measured values are susceptible to be present.	
Temperature range for use:	-15°C – 45°C
Relative humidity:	30 % – 90 %
Max. height for installation:	1000 m (**)
Max. wind speed (SERVICE):	55 Km/h
Max. wind speed (ERECTION):	45 Km/h
Max. wind speed (OUT OF SERVICE *):	130 Km/h

(*) Position OUT OF SERVICE corresponds with hoist at the lowest point and power supply disconnected.

(**) For installation in locations above 1000 m of height., and if the temperature exceeds 45° C, ask to manufacturer for limitations.

2. ASSEMBLY OF THE MACHINE

2.1. Introduction.

The following section is dedicated to the safely assembly of the machine. The installation of the hoist can only be performed by qualified personnel authorized to travel on it.



WARNING:

TO MOUNT THE ELEVATOR SHALL BE USED PROTECTIVE EQUIPMENT AGAINST FALLS FROM HEIGHT (ACCORDING TO EN 358, EN 361, EN 364) AND IN ANY CASE A PROTECTIVE HELMET FOR THE HEAD (ACCORDING TO EN 397), PLUS ADDITIONAL MEANS OF PROTECTION.



It is important to follow the instructions in detail, to avoid risks in the assembly and disassembly process. The user is obliged to observe, by himself, and for those working in the vicinity, all sources of additional risk, and to comply with all applicable safety standards for the type of equipment used.

2.2. Transport of the hoist.

The hoist is supplied unmounted, unless specifically indicated otherwise. See chapter 1.4 to know weight and dimensions for handling.



WARNING:

VERIFY THAT THE SOIL IS CAPABLE OF SUPPORTING THE LOAD TRANSMITTED BY THE HOIST. SEE THE TABLE:

2.3. Requirements on installation site. Requirements for ground support.

MAX. LOAD TRANSMITTED TO THE GROUND				
Height (*)	Weight: Hoist	Weight: Base frame + mast	TOTAL LOAD (STATIC)	TOTAL LOAD (DINAMIC Cd: 1,7)
5 m	3,92 KN	0,78 KN	4,71 KN	7,55 KN
10 m		1,37 KN	5,29 KN	8,04 KN
15 m		1,96 KN	5,88 KN	8,63 KN
20 m		2,55 KN	6,47 KN	9,22 KN
25 m		3,14 KN	7,06 KN	9,81 KN
30 m		3,73 KN	7,65 KN	10,03 KN
35 m		4,32 KN	8,24 KN	10,98 KN

(*) For higher installation, ask the manufacturer.

(x225) = [lbf]

2.4. Requirements for the electrical connection.

One phase:

- Supply point 230V 50/60 Hz with thermal protection 16A and differential protection of 300mA.
- Cable 3x2,5mm² connected direct to supply point, with max. length of 30m, with no other machines connected, to avoid voltage fault or losses of power in motor.

Three phases:

- Supply point 400V 50Hz with thermal protection 16A with 4 poles and differential protection of 300mA.
- Cable 4x2,5mm² connected direct to supply point, with max. length of 30m, with no other machines connected, to avoid voltage fault or losses of power in motor.

2.5. Erection of the hoist.

2.5.1. Placement of the base machine.

Pay special attention when moving the MC250 for positioning on the scaffolding. The MC250 has a front leg to give stability to the assembly.

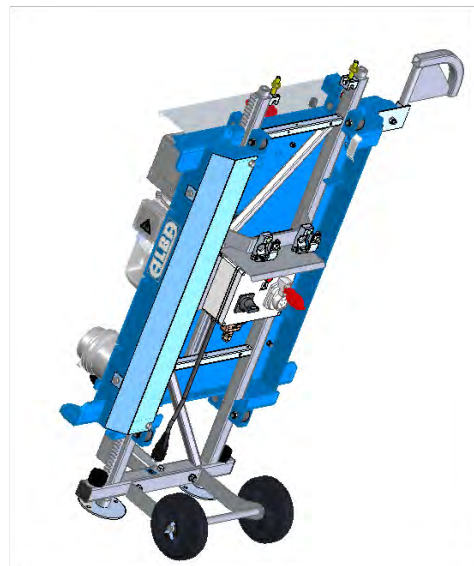
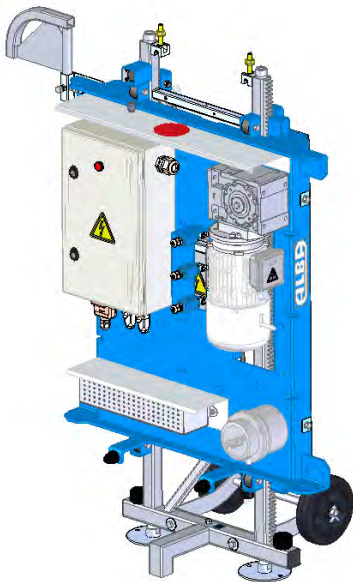

BASE POSITIONING

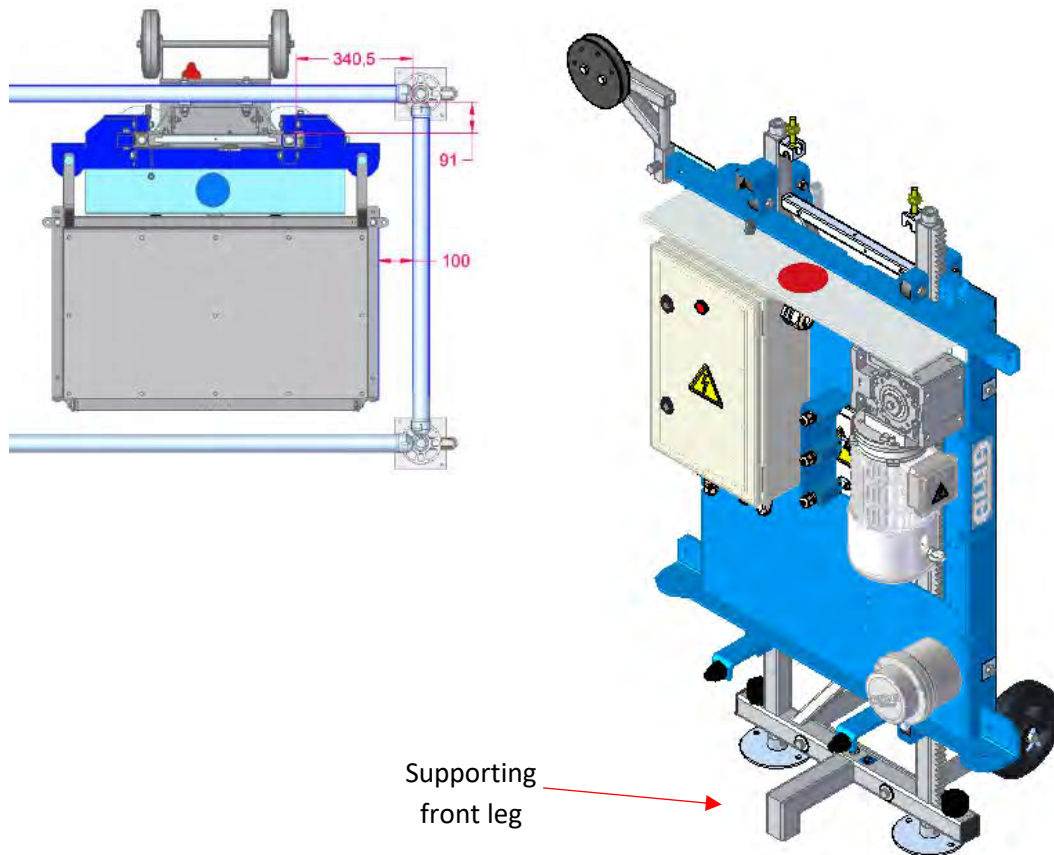

PLACE THE HOIST AT THE INSTALLATION SITE

2.5.2 Adjusting the spindle and fixing the base to the ground.

The MC 250 has two regulation spindles at the base to ensure that the mast is vertical and parallel to the scaffold tubes.

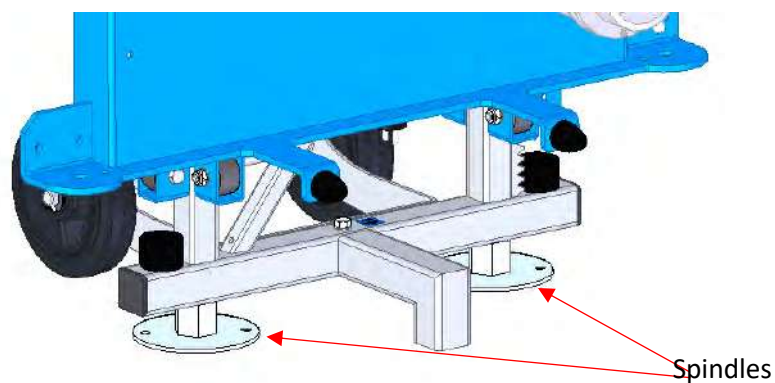

PLACE THE HOIST AT THE INSTALLATION SITE

Once the height is adjusted, we will fix the base to the ground by means of two anchoring spits that we will insert into the holes of the spindle base:

Anchoring points

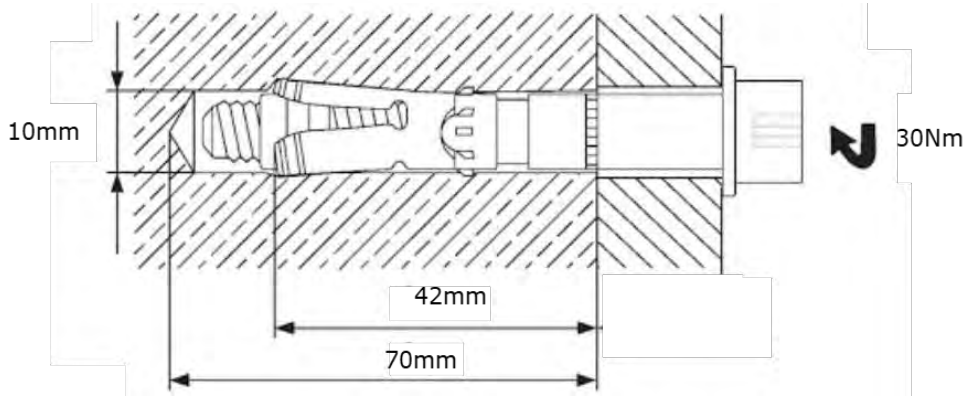
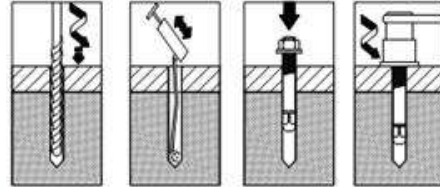
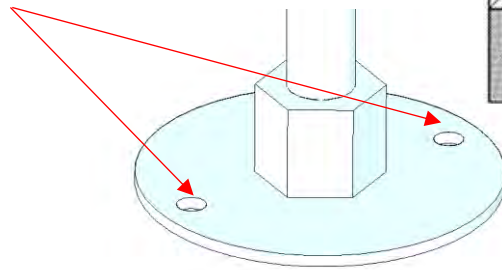

FIXING TO GROUND



WARNING:

**FIX THE BASE TO THE GROUND TO PREVENT THE HOIST FROM SLIPPING.
IN CASE IT IS NOT POSSIBLE TO FIX THE BASE TO THE GROUND, THE FIRST ANCHORAGE OF THE MAST SHALL BE MADE AT A HEIGHT OF LESS THAN 1 M**

2.5.3 Fixing the hoist to the structure.



WARNING:

ONCE THE HOIST IS FASTENED TO THE GROUND AND PERFECTLY VERTICAL, IT SHALL BE ANCHORED TO SUPPORTING STRUCTURE.

Before anchoring the MC250 to the scaffold check that the lower endtrack cam is positioned on the chassis. The cam slider is welded to the first mast; we must check that the cam is screwed to the slider.

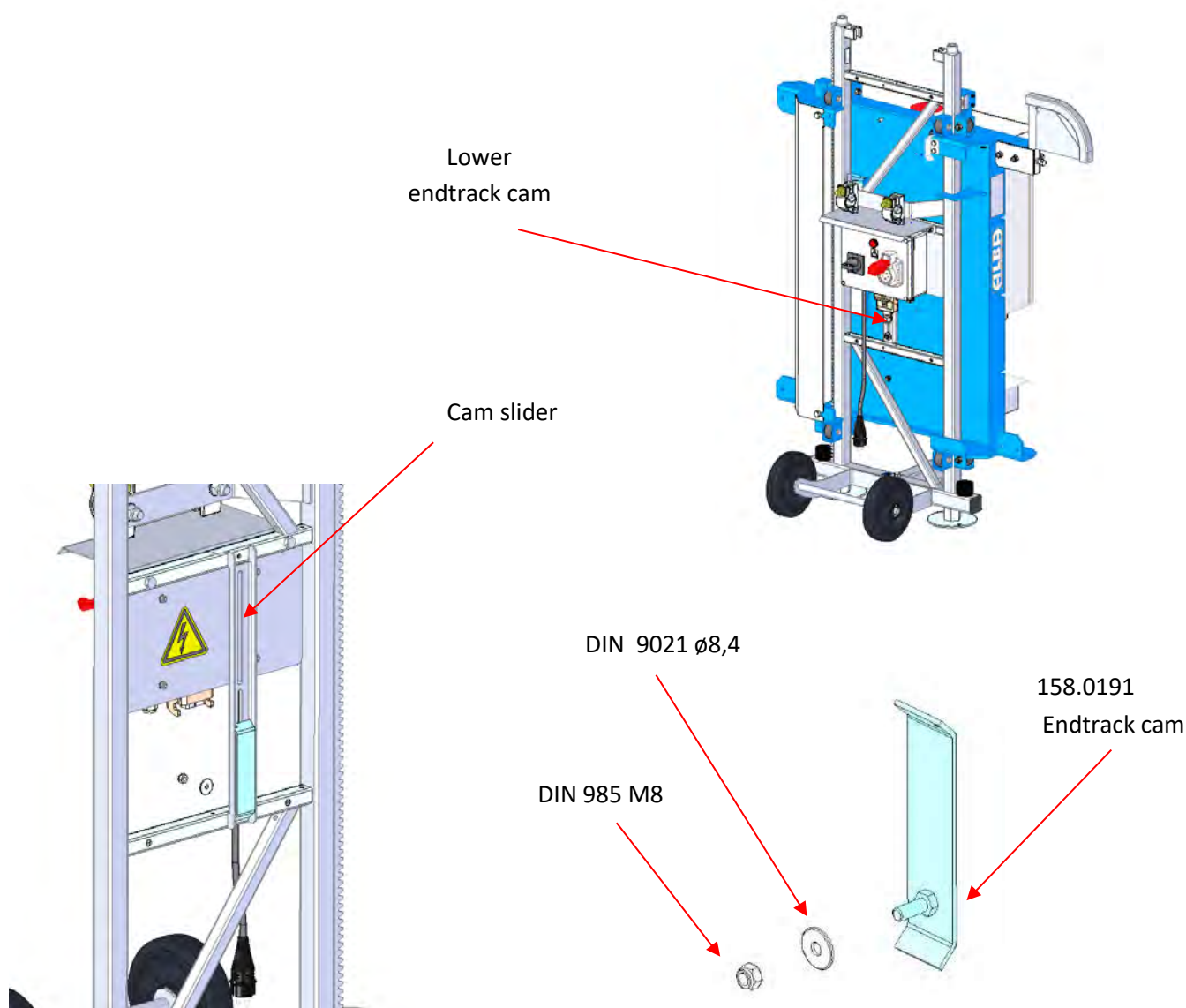

FIT THE LOWER ENDTRACK CAM

2.5.4 Mast column erection

The masts are joined through two T M14 shaped screws. The nuts of these screws have a notch that prevents them from losing. Due to this the screw cannot be separated from the mast. The screws are tightened with the scaffolding assembly ratchet spanner:

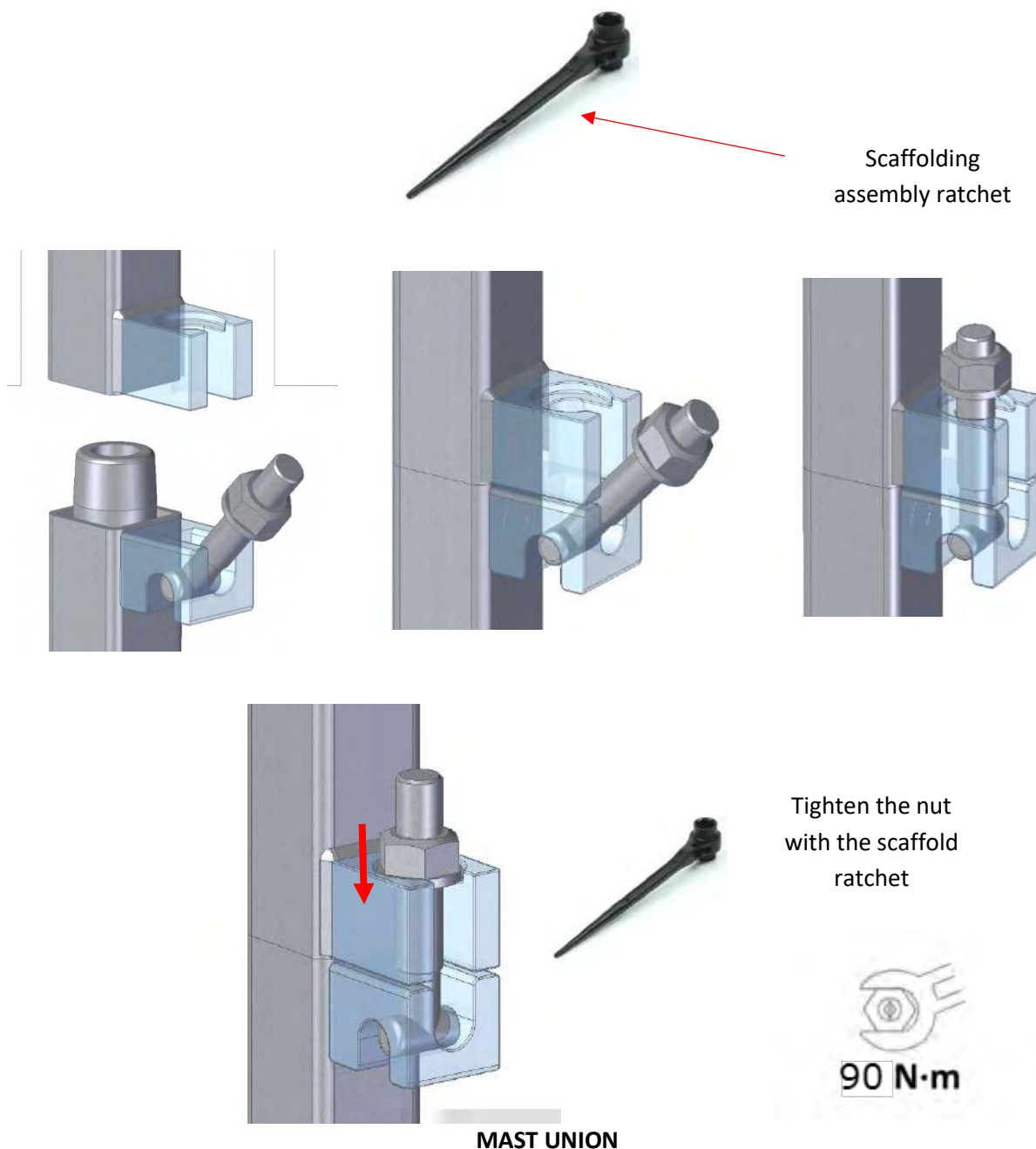

WARNING:
 WHEN JOINING EACH PAIR OF MASTS, CHECK THAT THE NUTS ARE TIGHT AND THAT THE ASSEMBLY BETWEEN MASTS IS CORRECT.
 REPLACE THE SCREWS AND NUTS THAT SHOW KNOCKS OR DENTS WITH NEW ONES. AN INCORRECT MAST JOINT COULD CAUSE A SERIOUS ACCIDENT.

2.5.5 First anchorage.

2.5.5.1 First anchorage of the mast (without external anchorages)

When we do not use external anchors, the first anchorage must be made with the clamps that the mast itself brings, at an approximate height of 1m.



WARNING:
WHEN WE ANCHOR THE MAST ITSELF TO THE SCAFFOLDING STRUCTURE, THE ANCHOR HEIGHT WILL BE APPROXIMATELY 1M.



FIRST ANCHOR TO STRUCTURE

2.5.5.2 First anchorage L type (158.81)



WARNING:
WHEN WE USE EXTERNAL ANCHORAGES THE FIRST ANCHOR MUST BE PLACED AT A MAXIMUM DISTANCE OF 2M.

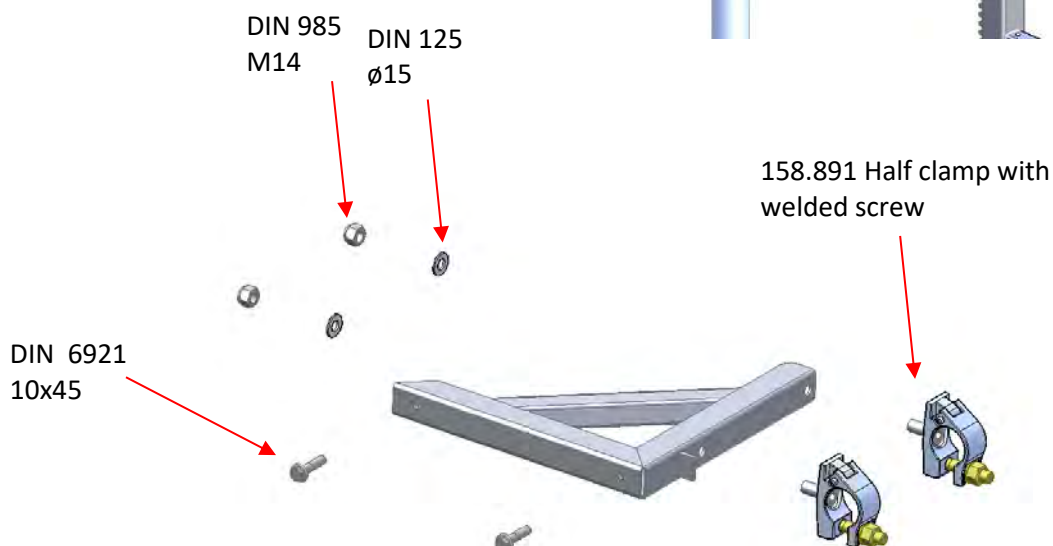

FIRST ANCHOR L-TYPE

2.5.5.3 First anchorage H Type (158.84)

WARNING:
WHEN WE USE EXTERNAL ANCHORAGES THE FIRST ANCHOR MUST BE PLACED AT A MAXIMUM DISTANCE OF 2M.

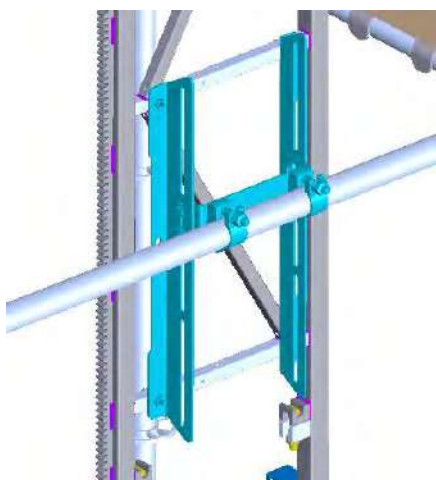
**40 N·m**

2m max.

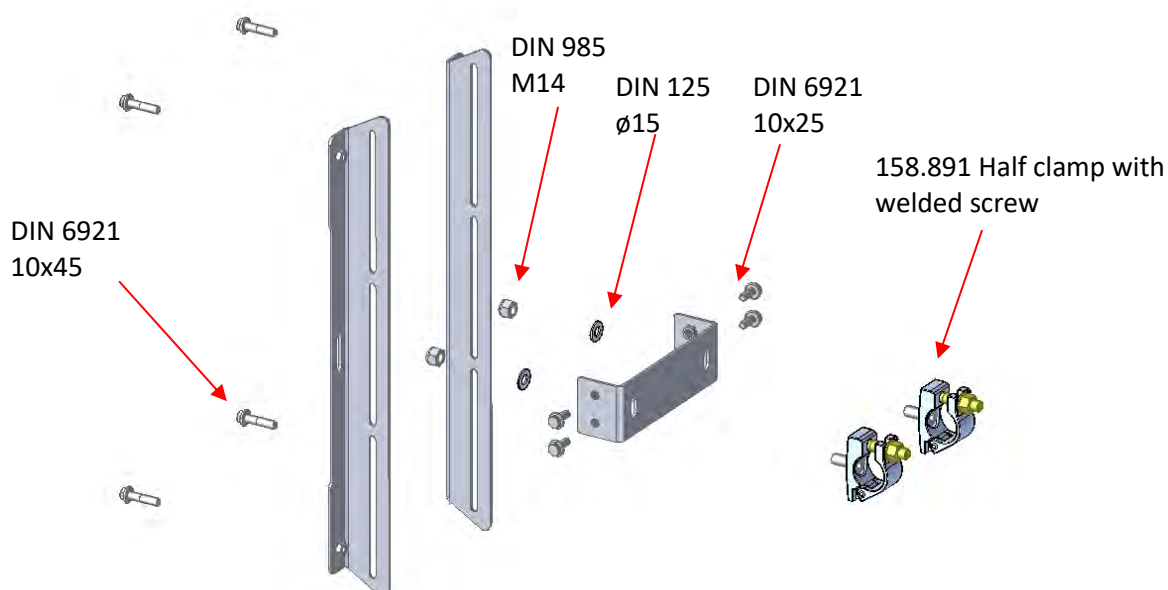
**FIRST ANCHOR H-TYPE**

2.5.6 Erection of the mast column



WARNING:
THE UPPER ENDTRACK CAM AND THE UPPER TRAVEL STOP MUST BE POSITIONED ON THE LAST MAST BEFORE PLACING ON IN THE COLUMN.

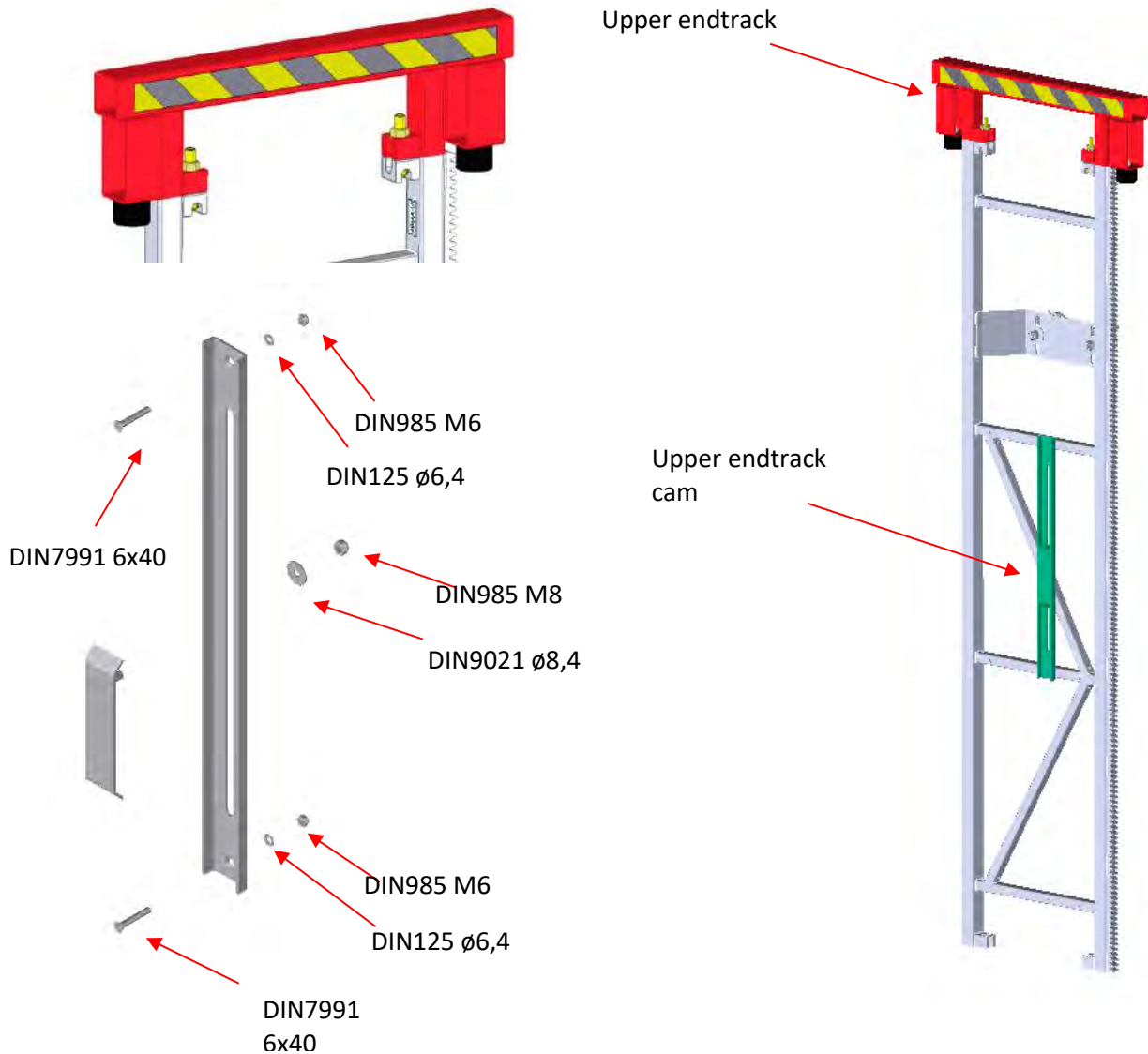

UPPER ENDTRACK CAM

The position of the upper endtrack cam is especially important, as it will limit the vertical travel of the MC 250. For safety and to avoid possible accidents due to mast breakage, the upper part of the MC 250 should never protrude more than 250mm from the last anchor.

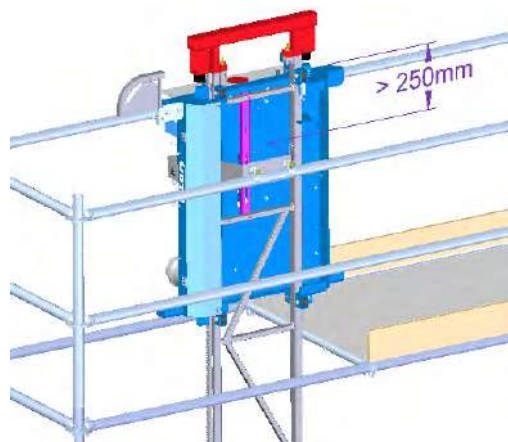
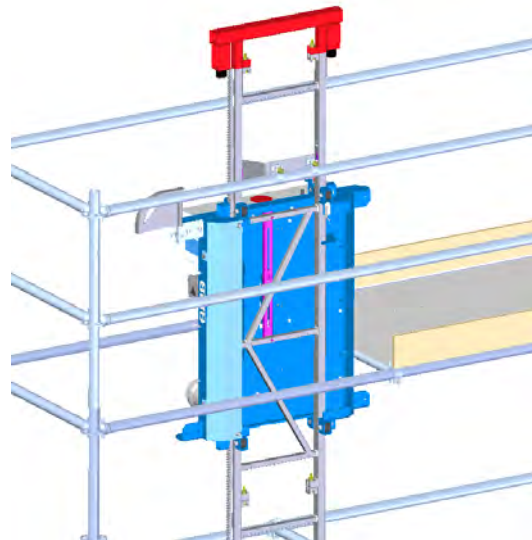
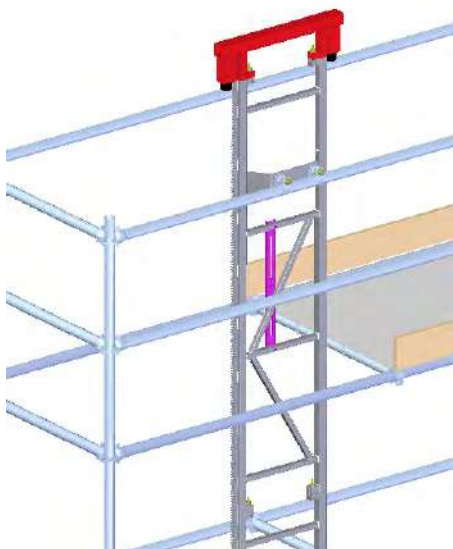

WARNING:
THE UPPER ENDTRACK CAM SHOULD BE POSITIONED SO THAT THE TOP OF THE MC 250 IS NEVER MORE THAN 250MM FROM THE LAST ANCHOR.

Below are pictures of the correct and incorrect mountings of the upper endtrack cam on the last mast:



CORRECT / INCORRECT POSITION OF UPPER ENDTRACK CAM - STANDARD

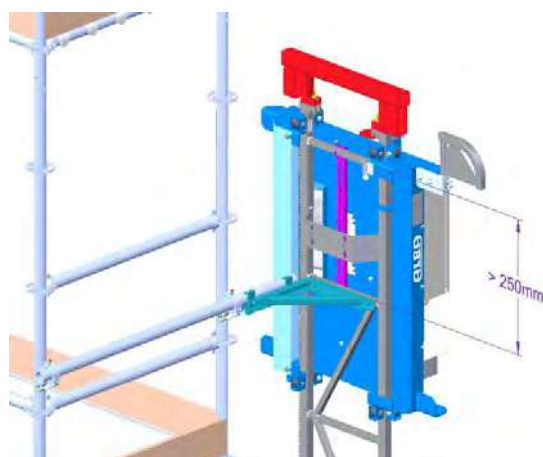
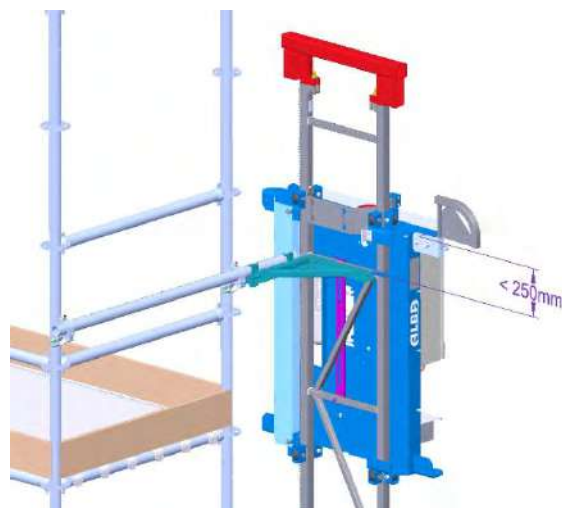
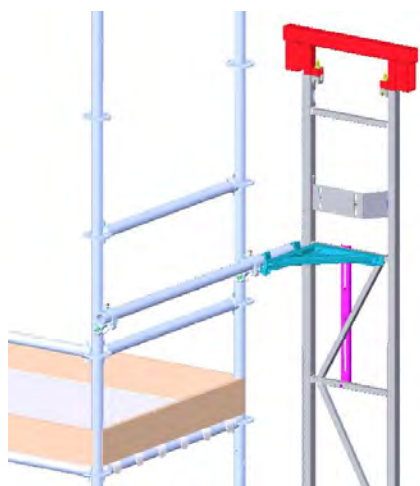
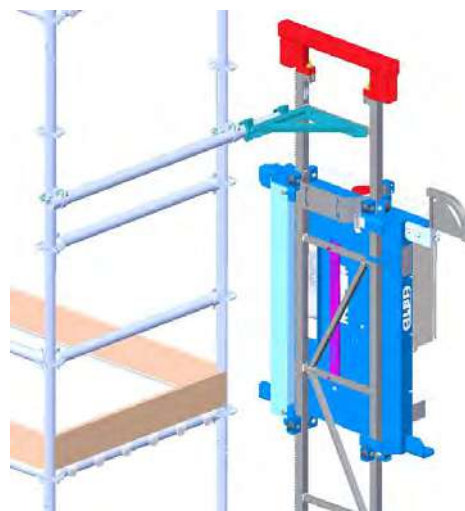
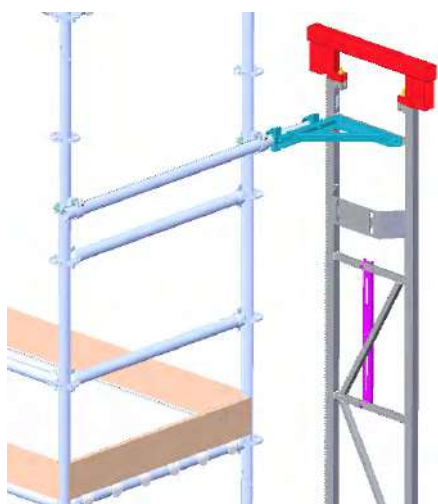

CORRECT / INCORRECT POSITION OF UPPER ENDTRACK CAM

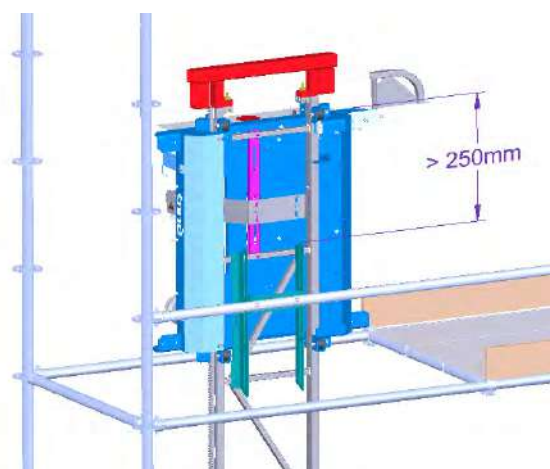
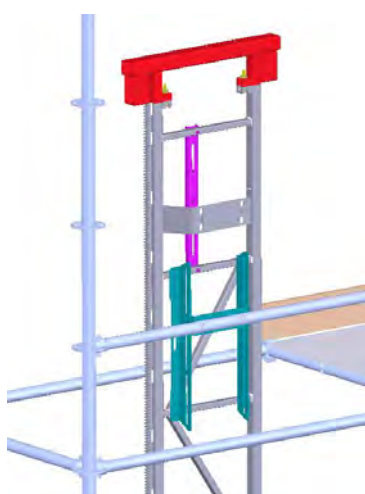
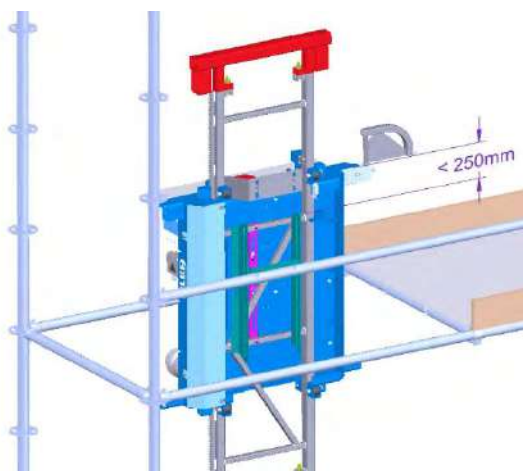
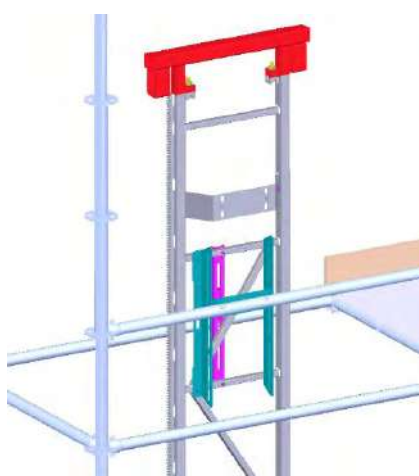
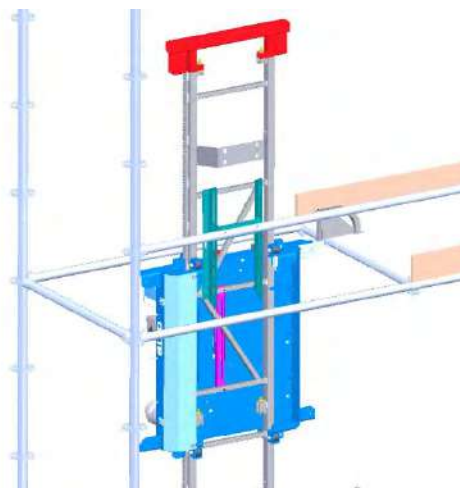

CORRECT / INCORRECT POSITION OF UPPER ENDTRACK CAM

2.5.6.1 Erection of the mast column without external anchorages

WARNING:

**INSTALL MAST AND SCREWS ALWAYS AT THE SAME TIME.
NEVER RAISE THE HOIST OVER A NON-SCREWED MAST MODULE, THEN THERE IS HIGH CHANCE OF COLLAPSE AND SERIOUS INJURY.**

WARNING:

THE DISTANCE BETWEEN ANCHORS IS FIXED (2M). OPERATIONS OF ERECTION OF MAST SHALL BE PERFORMED FROM OUTSIDE THE CARRIER. IT IS FORBIDDEN TO TRANSPORT PEOPLE IN THE CAGE TO ERECT THE MAST COLUMN.

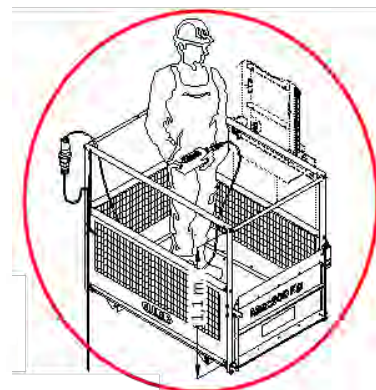
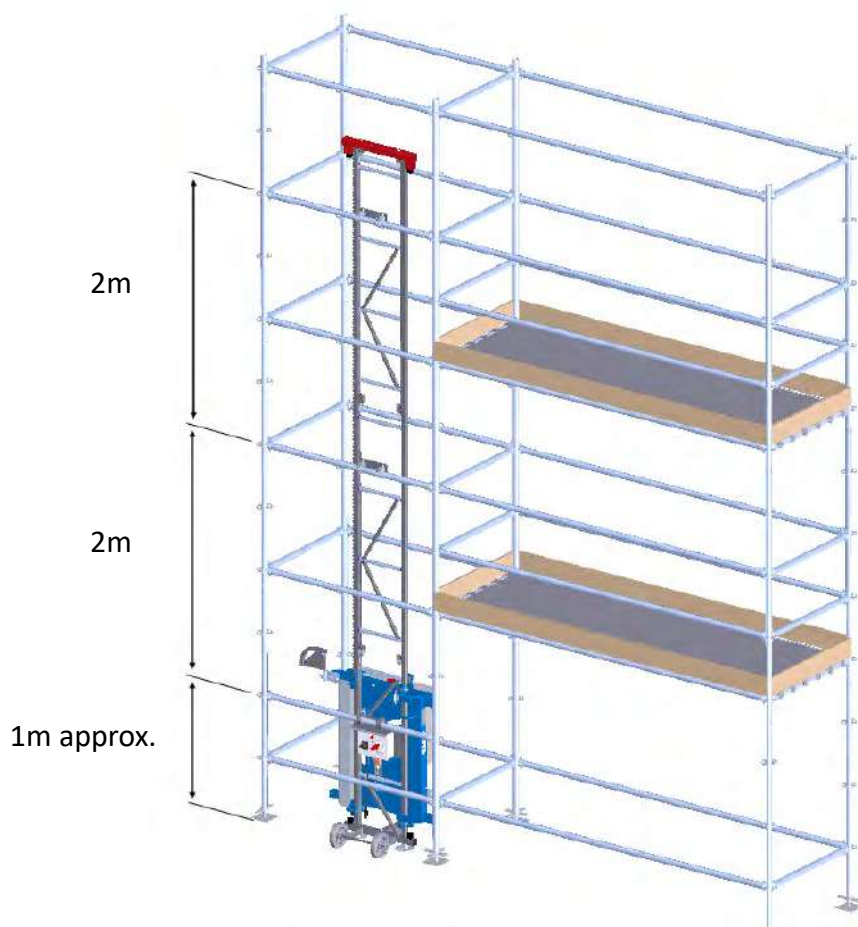
INSTALLING MAST WITHOUT EXTERNAL ANCHORAGES

ADVERTENCIA:

SI EL MONTAJE SE HACE POR UNA PERSONA EN LA JAULA ACCESIBLE LA DISTANCIA MÁXIMA ENTRE ANCLAJES EXTERNOS SERÁ DE 2M. PARA EL MONTAJE CON JAULA ACCESIBLE SERÁ OBLIGATORIO UTILIZAR EL PROLONGADOR DEL MANDO DE CONTROL PARA PODER MANEJARLO DESDE DENTRO DE LA JAULA.

2.5.6.2 Erection of the mast column with external anchorages



WARNING:
INSTALL MAST AND SCREWS ALWAYS AT THE SAME TIME.
NEVER RAISE THE HOIST OVER A NON-SCREWED MAST MODULE, THEN THERE IS HIGH CHANCE OF COLLAPSE AND SERIOUS INJURY.



WARNING:
THE DISTANCE BETWEEN ANCHORS IS FIXED (2M). OPERATIONS OF ERECTION OF MAST SHALL BE PERFORMED OUTSIDE THE CARRIER. IT IS FORBIDDEN TO TRANSPORT PEOPLE IN THE CAGE TO ERECT THE MAST COLUMN.

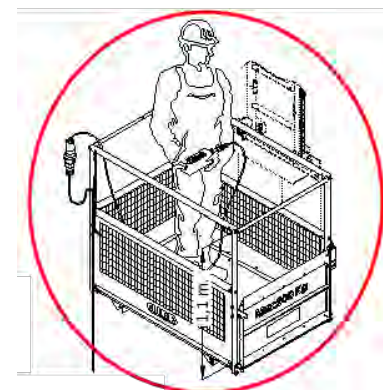
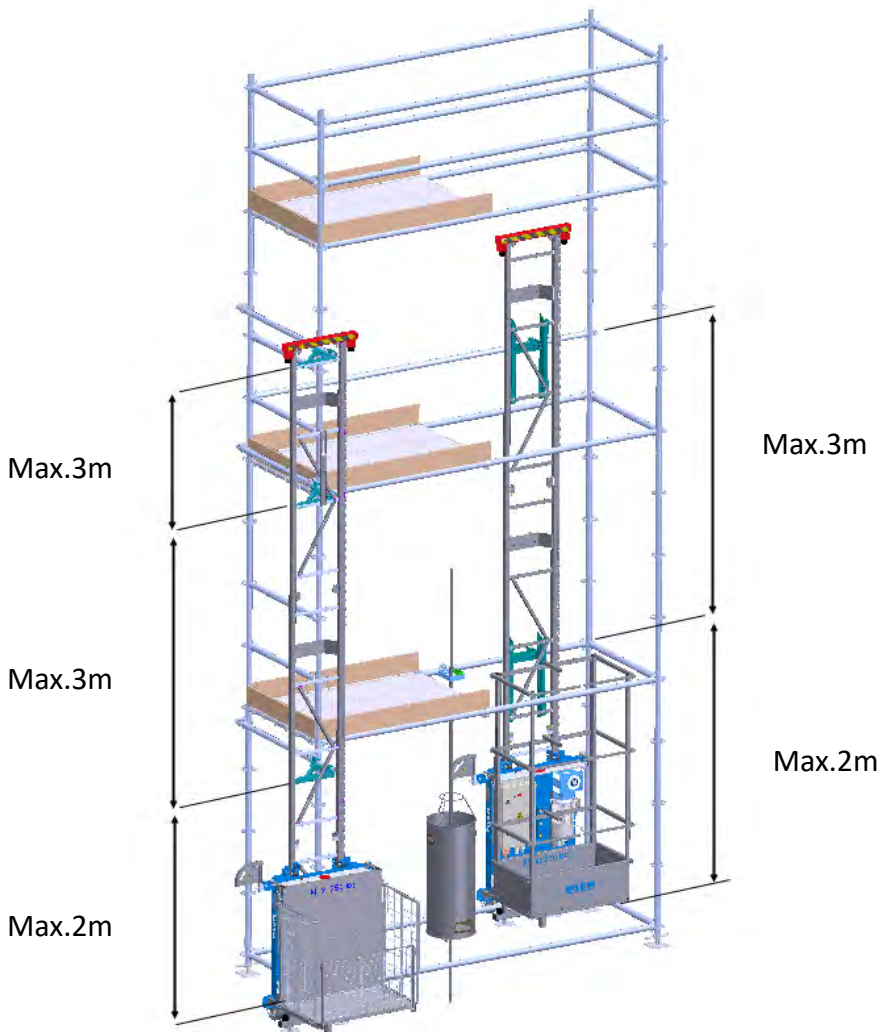

INSTALLING MAST WITH EXTERNAL ANCHORAGES



WARNING:
IF THE ASSEMBLY IS DONE BY ONE PERSON IN THE ACCESSIBLE CAGE, THE MAXIMUM DISTANCE BETWEEN EXTERNAL ANCHORAGES WILL BE 2M. FOR THE ASSEMBLY WITH ACCESSIBLE CAGE IT WILL BE MANDATORY TO USE THE EXTENSION OF THE CONTROL KNOB TO BE ABLE TO OPERATE IT FROM THE CAGE

2.5.7 Reaction forces in the anchors

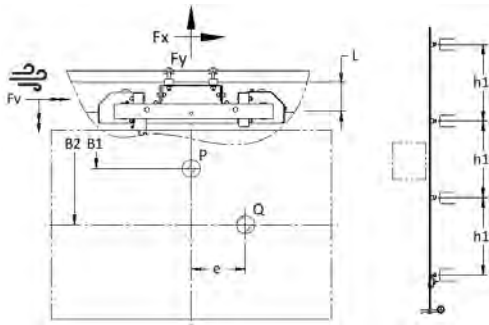
REACTION FORCES ($h_1 = 2 \text{ m}$) ($L = 100 \text{ mm}$)
STANDARD AND H ANCHOR – 900x500 CARRIER

F_x	1,21KN
-------	--------

F_y	2,18KN
-------	--------

STANDARD AND H ANCHOR – 900x650 CARRIER

F_x	1,21KN
-------	--------

F_y	2,44KN
-------	--------

STANDARD AND H ANCHOR – SCAFFOLDING CARRIER

F_x	1,21KN
-------	--------

F_y	2,40KN
-------	--------

STANDARD AND H ANCHOR – ACCESIBLE CAGE (90°)

F_x	0,97KN
-------	--------

F_y	2,10KN
-------	--------

(x225) = [lbf]

REACTION FORCES ($h_1 = 2 \text{ m}$) ($L = 430 \text{ mm}$)
L ANCHOR – 900x500 CARRIER
SCAFFOLD WIDTH (W)

0,7 m	1 m	1,15 m
-------	-----	--------

F_x	1,54KN	1,08KN	0,94KN
-------	--------	--------	--------

F_y	3,71KN	3,71KN	3,71KN
-------	--------	--------	--------

L ANCHOR – 900x650 CARRIER
SCAFFOLD WIDTH (W)

0,7 m	1 m	1,15 m
-------	-----	--------

F_x	1,54KN	1,08KN	0,94KN
-------	--------	--------	--------

F_y	3,99KN	3,99KN	3,99KN
-------	--------	--------	--------

L ANCHOR – SCAFFOLDING CARRIER
SCAFFOLD WIDTH (W)

0,7 m	1 m	1,15 m
-------	-----	--------

F_x	1,59KN	1,11KN	0,97KN
-------	--------	--------	--------

F_y	4,03KN	4,03KN	4,03KN
-------	--------	--------	--------

L ANCHOR – ACCESIBLE CAGE (0°)
SCAFFOLD WIDTH (W)

0,7 m	1 m	1,15 m
-------	-----	--------

F_x	1,42KN	1,00KN	0,87KN
-------	--------	--------	--------

F_y	4,19KN	4,19KN	4,19KN
-------	--------	--------	--------

(x225) = [lbf]

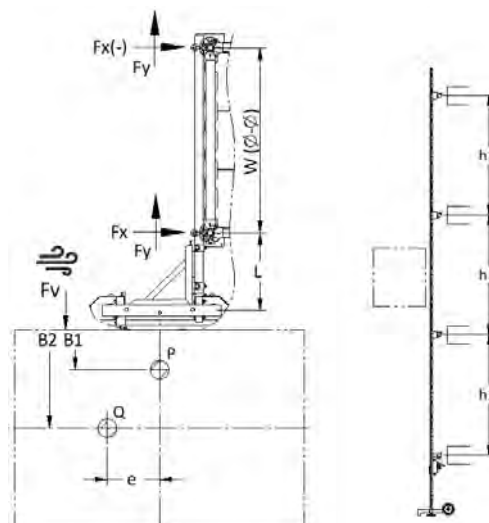
WARNING:

MAKE SURE THAT EXTERNAL STRUCTURE SUPPORTS LOADS TRANSMITTED BY THE ANCHORS, USING TABLE DATA.

CASE OF ANCHORAGE TO SCAFFOLD STRUCTURE, IT MUST BE FIXED TO THE BUILDING AT APPROPRIATE INTERVALS, TO ENSURE STABILITY.

FOR OTHER INSTALLATION CASES, ASK THE MANUFACTURER

2.5.8 Wall anchorages

2.5.8.1 Anchorage without external anchorages (minimum distance)

The mast is designed to be anchored directly to the wall without external anchorages or with H type anchors (158.84).

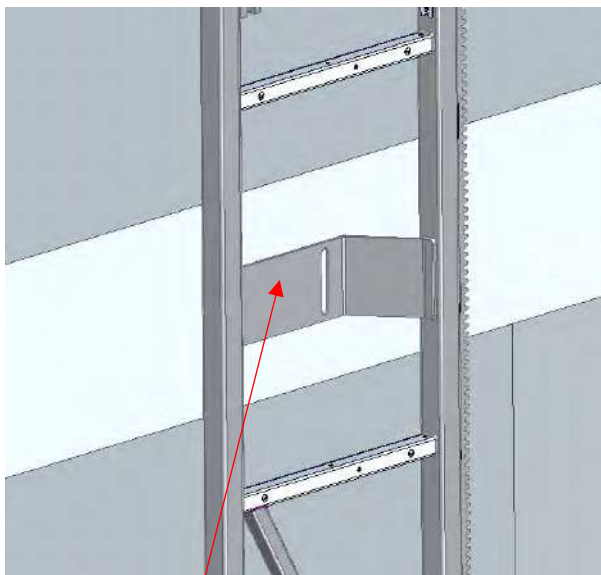

Direct wall anchor

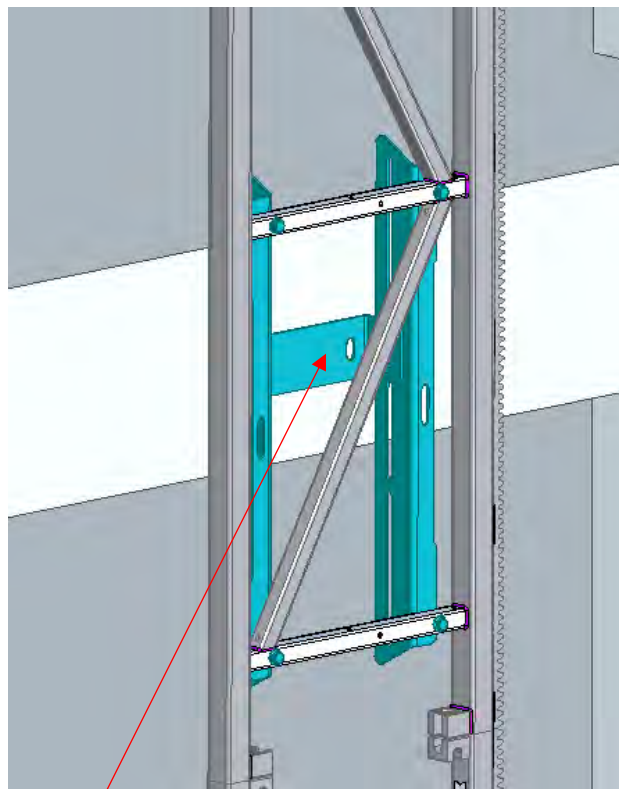

Wall anchor with H type anchor (158.84)

ANCHOR TO WALL

2.5.8.2 Special anchor for mounting the mast column perpendicular to the wall: 158.8610

The MC250 mast can be directly tied to the fixed anchor perpendicular to the wall.
 If, due to the configuration of the building, it is not possible to use the anchor point of the masts, H type anchors can be used (158.84).

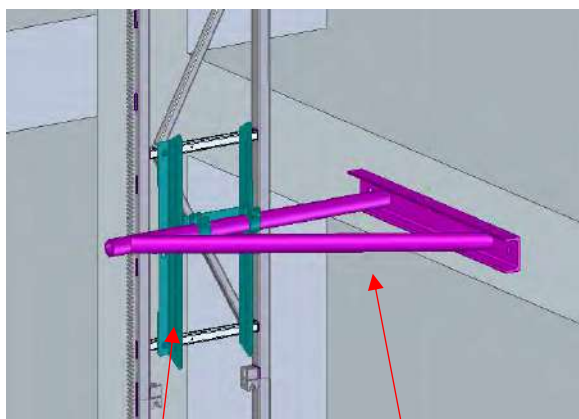
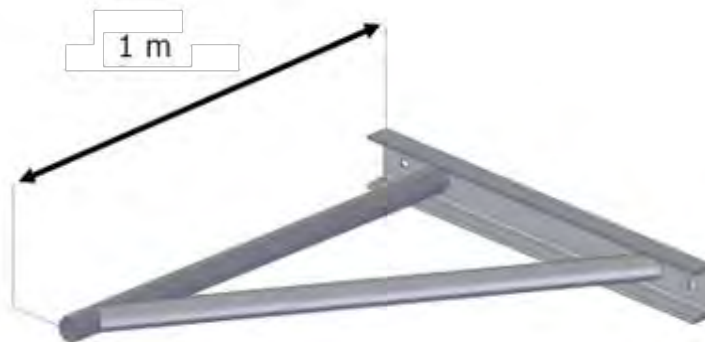

H type anchor
(158.84)

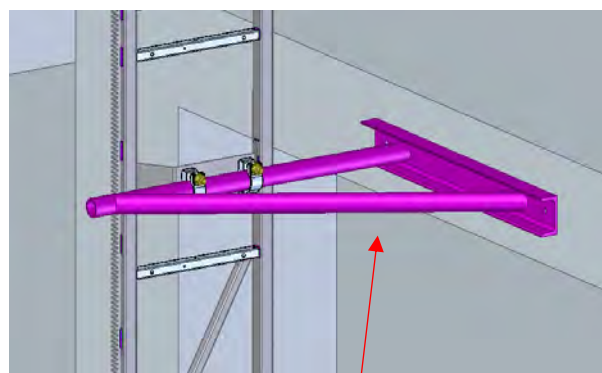

Special fixed anchorage
perpendicular to the
wall 158.86

Special fixed anchorage
perpendicular to the
wall 158.86

PERPENDICULAR TO WALL INSTALLATION

2.5.8.3 Special fixed anchorage for mounting the mast column parallel to the wall: 158.8700

The MC250 mast can be directly tied to the fixed anchor parallel to the wall.
 If, due to the configuration of the building, it is not possible to use the anchor point of the masts, H type anchors can be used (158.84).

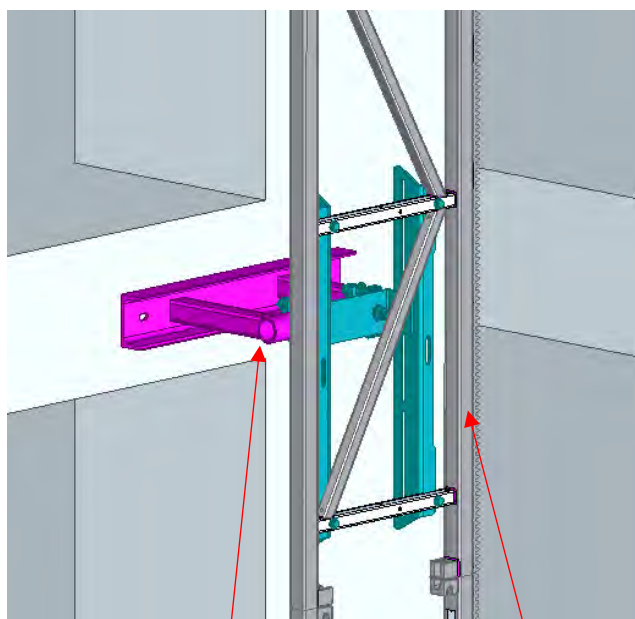
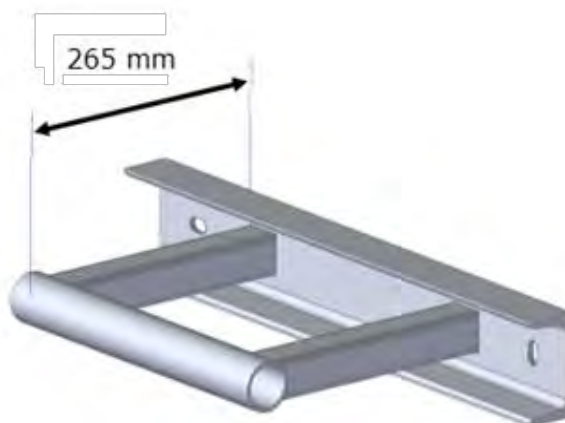

Special fixed anchorage parallel to the wall 158.8700

H type anchor (158.84)

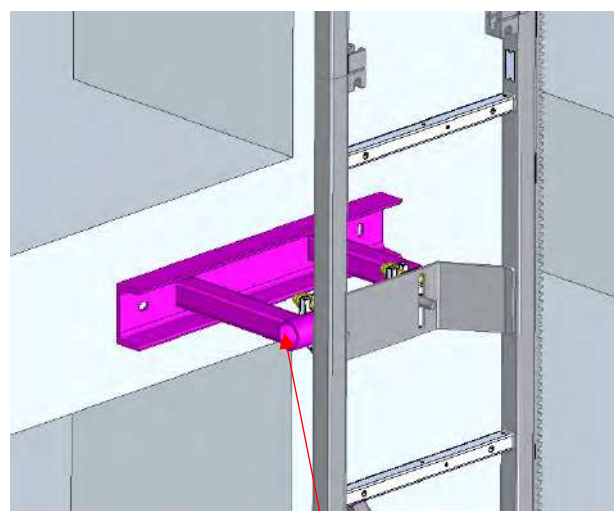

Special fixed anchorage parallel to the wall 158.8700

PARALLELL ANCHOR INSTALLATION

2.5.8.4 Extensible anchorage for mounting the mast column parallel to the wall: 158.8500

The MC250 mast can be anchored directly to the fixed anchorage parallel to the extensible wall. If due to the configuration of the building it is not possible to use the anchor points of the masts themselves, type H anchors (158.84) can be used.

The extensible anchor can be mounted for distances between 444 and 694mm.

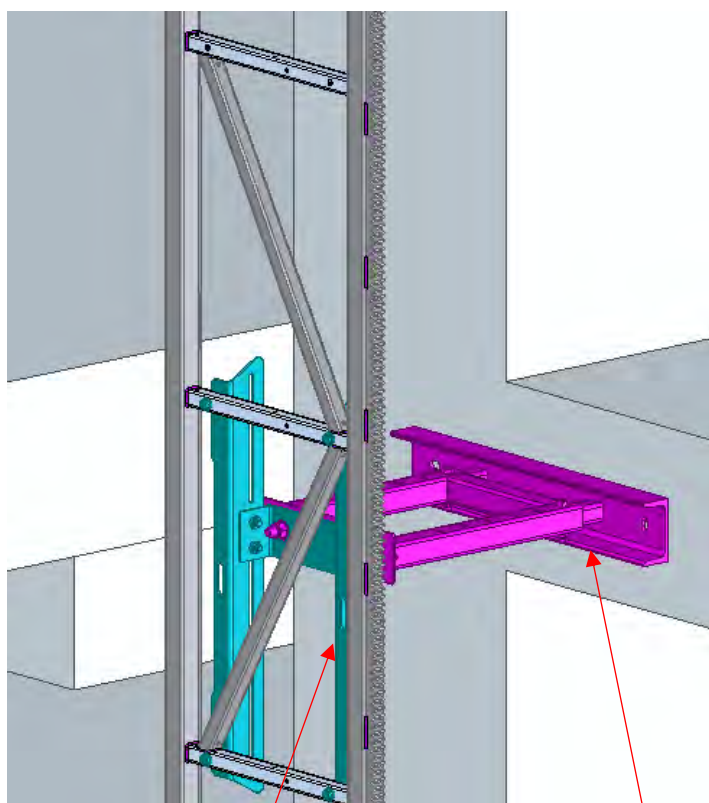
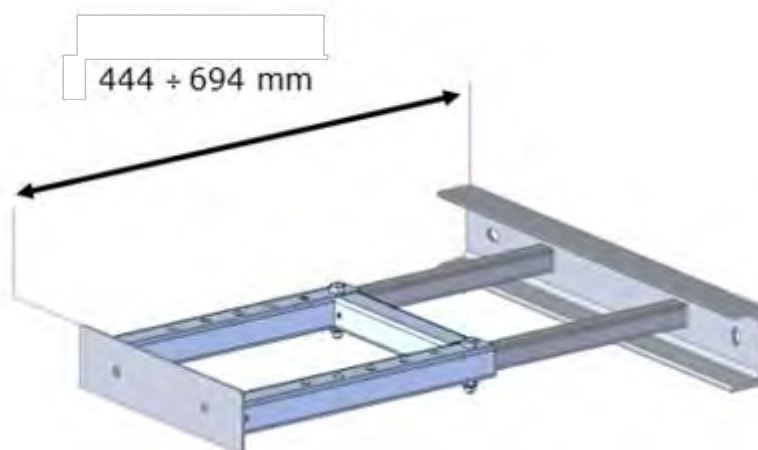

H type anchor (158.84)

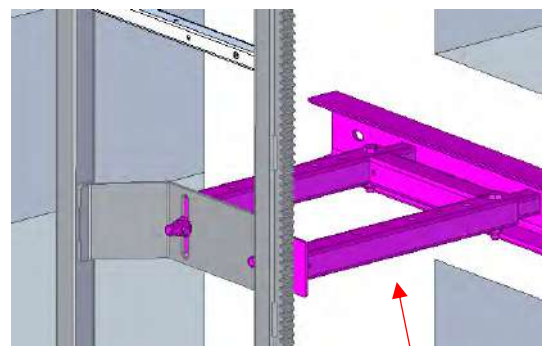

Special extensible anchorage parallel to the wall 158.8500

Special extens anchorage paral the wall 158.8

EXTENSIBLE PARALLELL ANCHOR INSTALLATION

2.5.9 Cage assembly

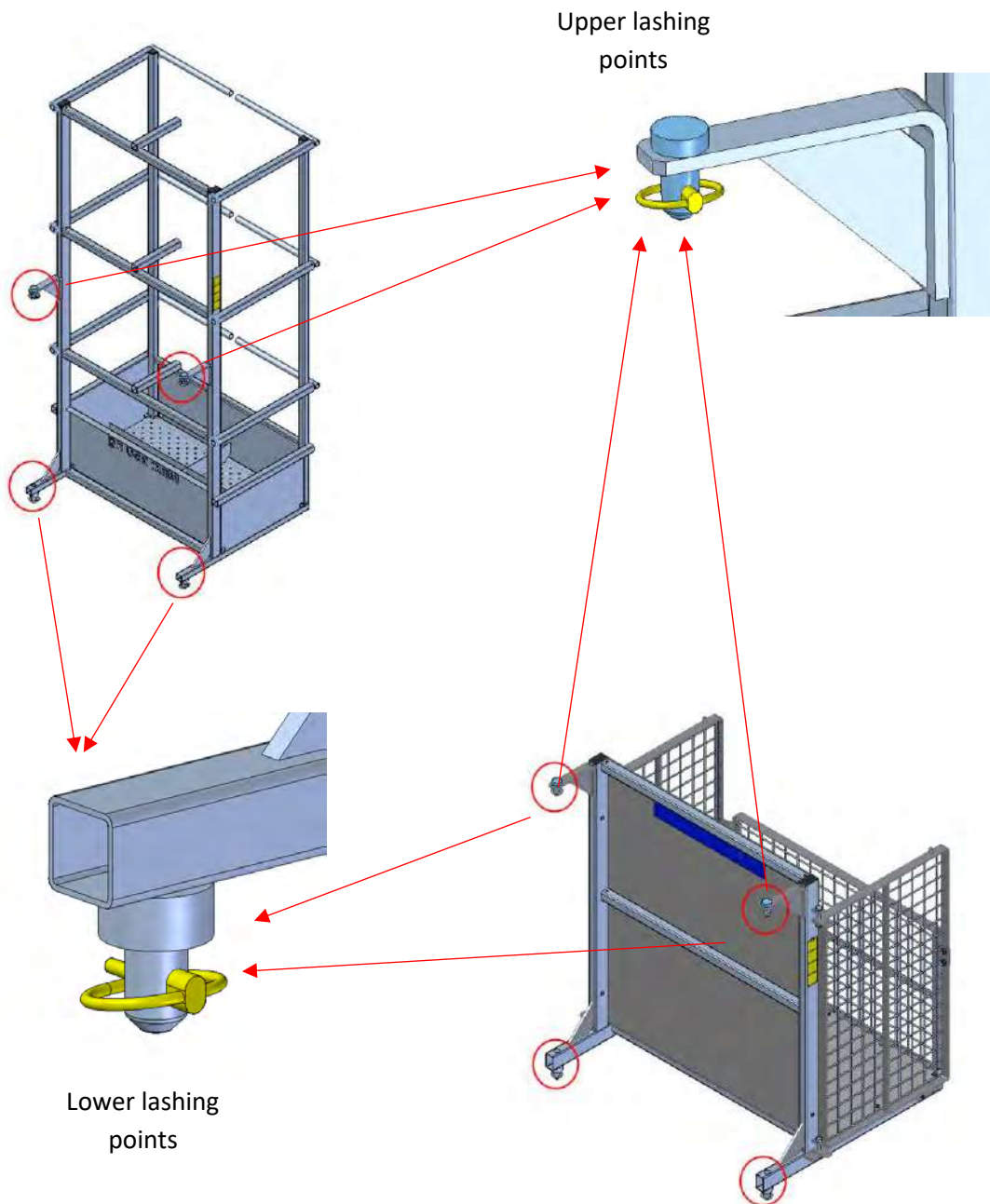

CAGE ASSEMBLY TO DRIVE UNIT

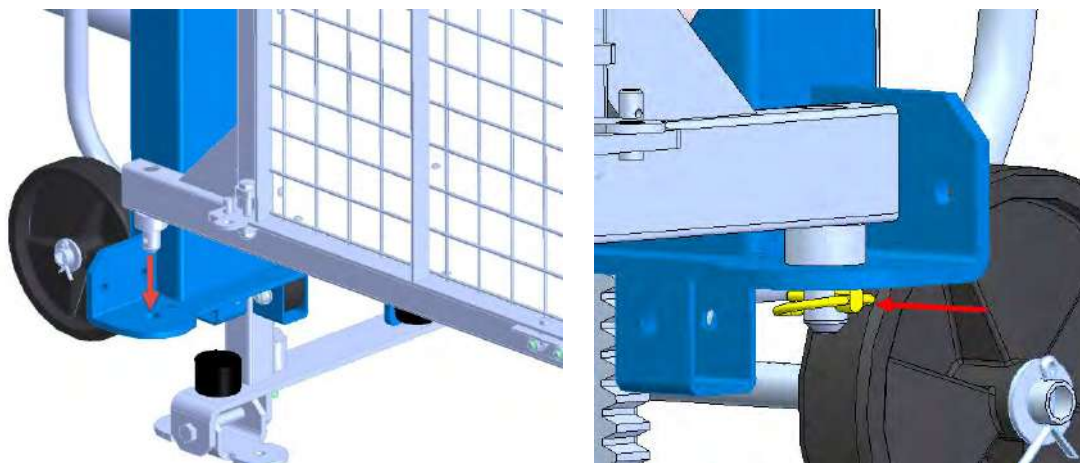

LOWER LASHING POINTS

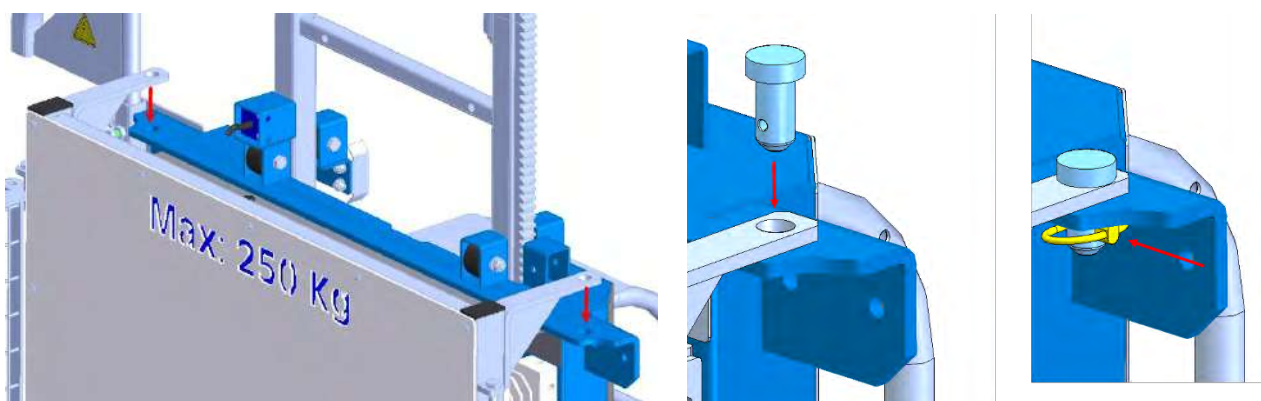

UPPER LASHING POINTS



WARNING:
 AFTER POSITIONING THE CAGE, CHECK THAT THE 4 PINS THAT CONNECT THE CAGE TO THE CHASSIS HAVE BEEN PERFECTLY CLOSED.

The scaffolding cage is supplied with a tube organizer (158.4226) to protect the mast from possible interference with tubes up to 3m:



SCAFFOLDING CARRIER

The upper set (158.4235) is optionally supplied to protect the mast from possible interference with tubes up to 4m:

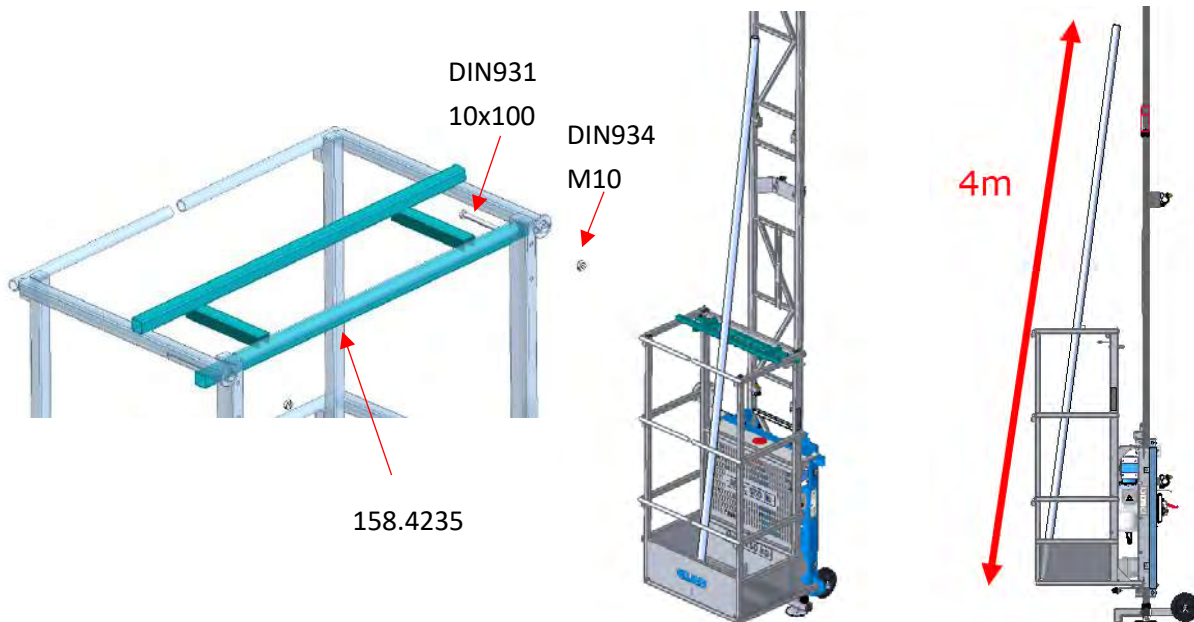

OPTIONAL TUBE SEPARATOR

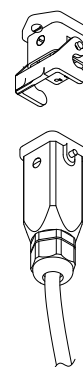
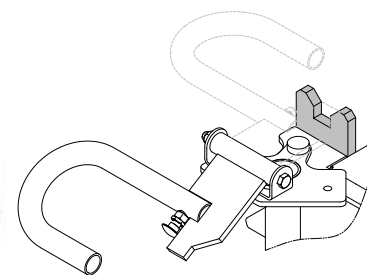
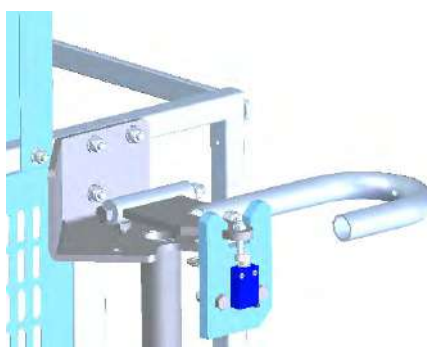
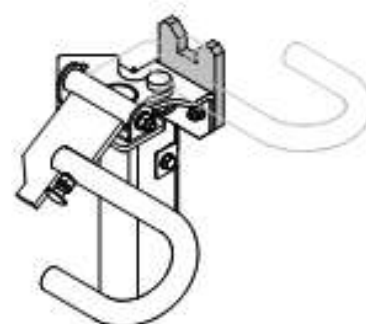
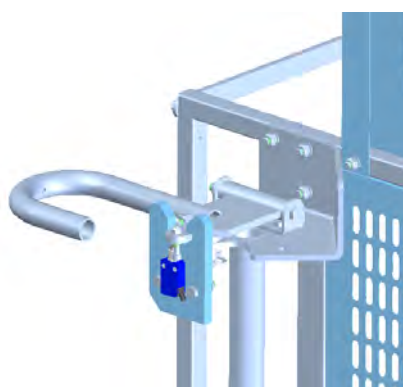

WARNING:
IT IS FORBIDDEN TO LIFT MATERIALS LONGER THAN 2,5M WITHOUT USING ONE OF THE MAST COLUMN PROTECTION ELEMENTS.

2.5.9.1 Accessible turning cage**MAIN COMPONENTS – ACESIBLE ROTATING CAGE****LEFT TURNING CAGE****RIGHT TURNING CAGE**

The cage is screwed to the rotating system at three points on the base:

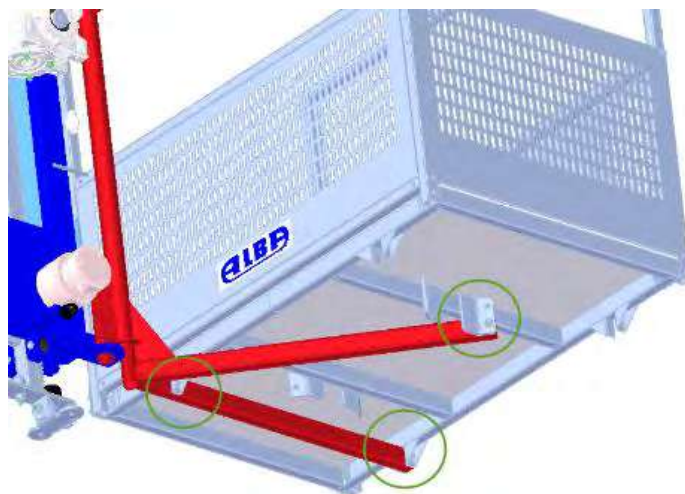

FITING THE CAGE



WARNING:
CHECK THAT THE SCREWS THAT JOIN THE BASKET TO THE TURNING SYSTEM ARE CORRECTLY TIGHTENED.

By default, the cages leave the factory prepared to make the right turn. If you want to use it with left turn, you will have to change the position of the cage door and its corresponding limit switches and latch:



A: RIGHT TURNING CAGE

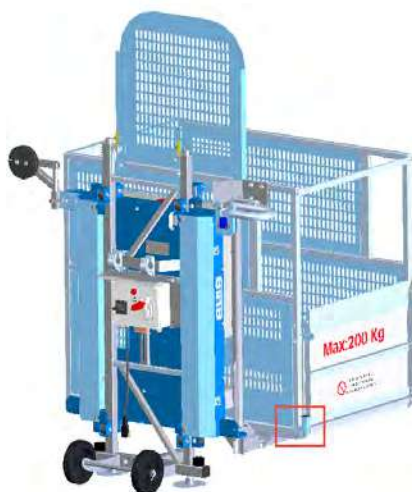

B: LEFT TURNING CAGE

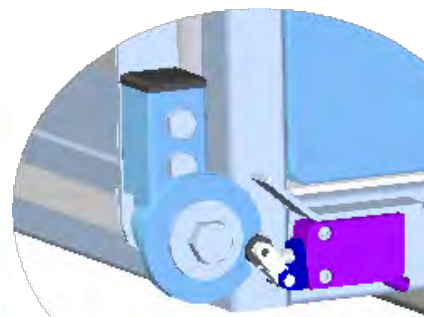

(A)

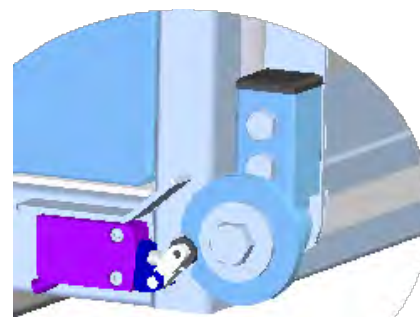

(B)

INSTALLING DOOR MICROSWITCH IN ACCESSIBLE CAGE

2.5.10 Installing cable holder, cable guides and electric connection

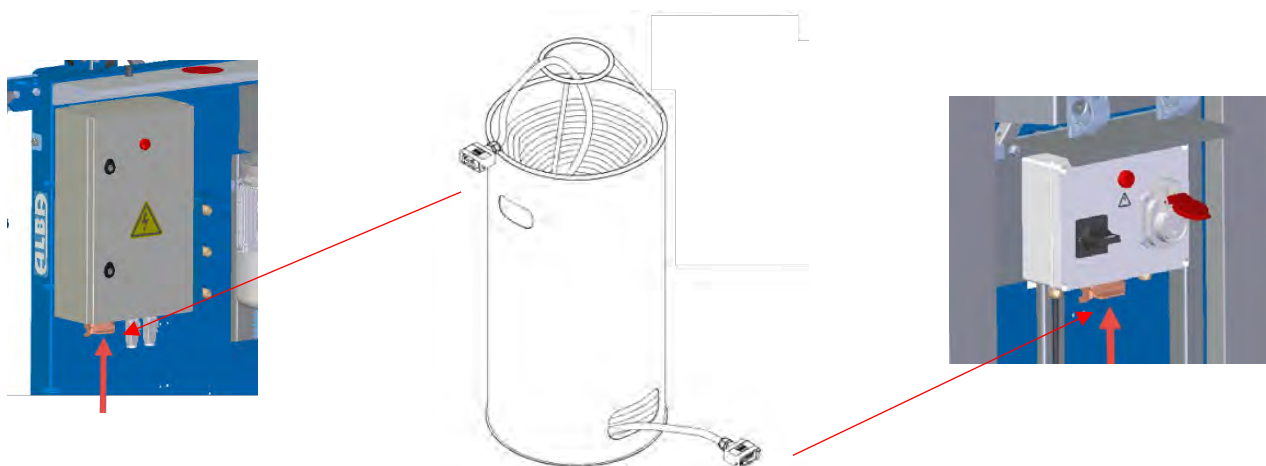

Cable holder - leftside



Cable holder - rightside



Fitting the cable on hanging bracket



Cable guide type 1 – vertical tube



Cable guide type 2 – horizontal tube

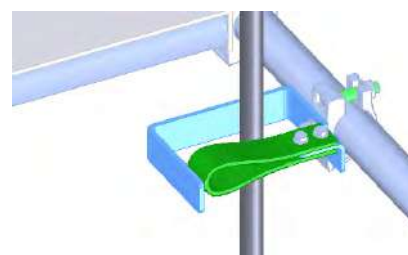

ELECTRIC CONNECTION AND CABLE HOLDER



WARNING:
MAKE SURE THAT THE CABLE IS ALIGNED WITH THE HOLDER AND ROLLS UP PERFECTLY. CHECK THAT THERE IS NO INTERFERENCE OF THE CABLE WITH CABLE GUIDES OR WITH THE MOVING PARTS OF THE HOIST.

2.5.11 Access protection

2.5.11.1 Ground level protection



WARNING:
IT IS MANDATORY TO PROTECT THE GROUND ACCESS LEVEL FOR LOAD, WITH VERTICAL PROTECTION OF $H = 1,1 \div 1,2$ M, AND ALSO INTERMEDIATE RAIL WITH NO MORE THAN 0,5 M VERTICAL DISTANCE.

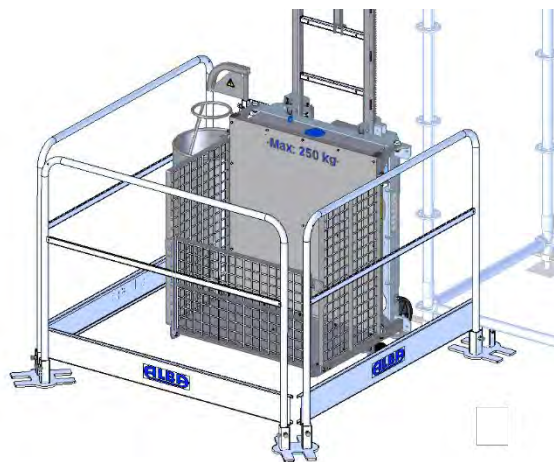

GROUND LEVEL PERIMETER PROTECTION

2.5.11.2 Vertical travel protection

Access of persons to vertical hoist travel shall be protected, to prevent accidents when there is risk of a fall from height more than 2 m.

If openings in the vertical travel protection are necessary to access the load, they should not exceed necessary width to allow the opening of the cage door.

2.5.11.3 Loading and unloading areas

In cases in which you can't designate default loading or unloading areas, where the hoist should be operated over the entire vertical travel, the hoist shall be operated from a point from which you have full visibility of complete travel.



WARNING:
THE HOIST SHALL BE OPERATED FROM A POINT FROM WHICH YOU HAVE FULL VISIBILITY OF COMPLETE TRAVEL.

2.5.12 Installing landing doors. Accessible cage

In the case of using accessible cage that requires access to the hoist at height for loading and unloading, landing doors must be installed at all access levels to avoid the hazard of people falling.

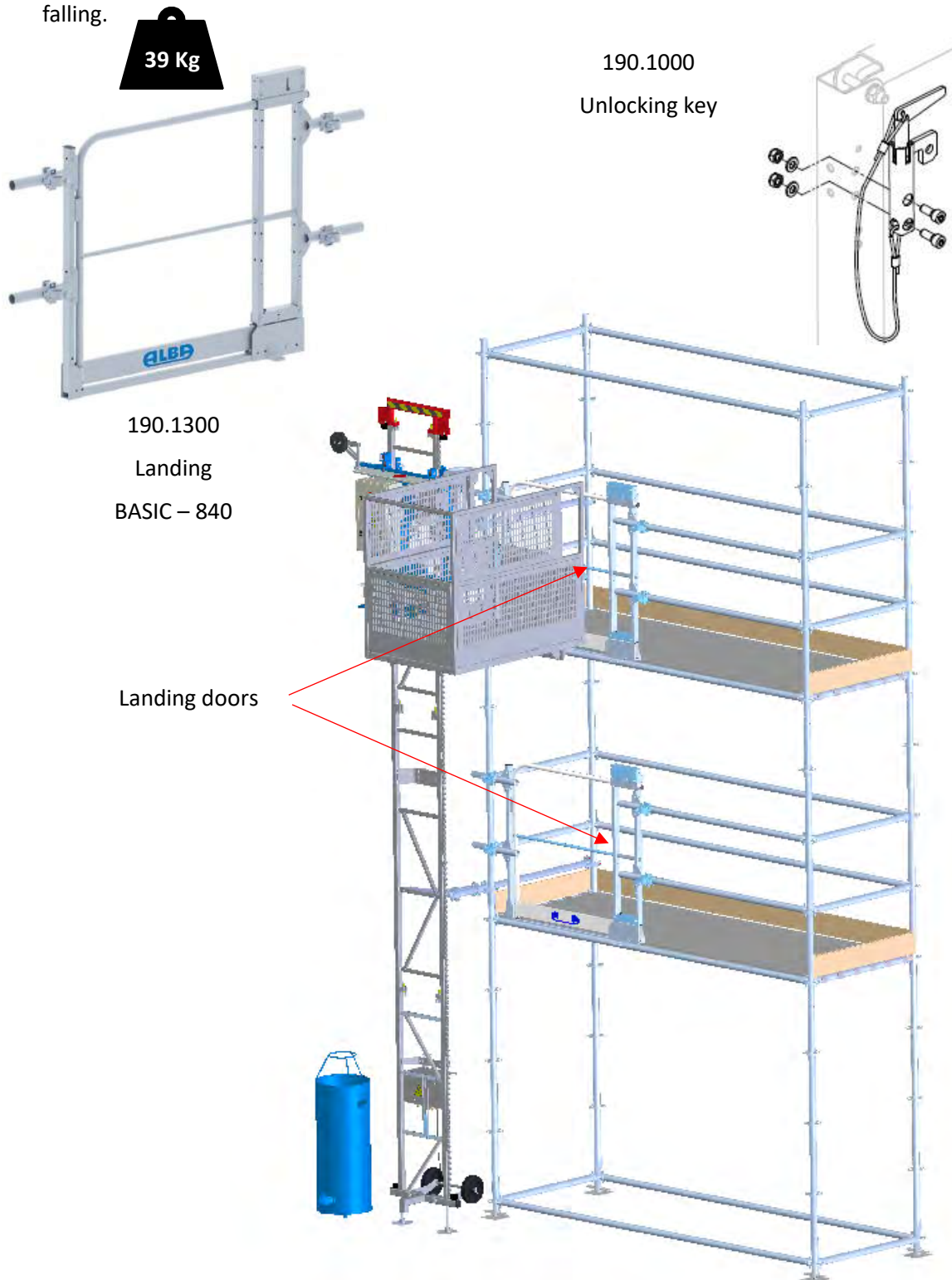

INSTALLING BASIC TYPE LANDING DOOR – ACCESIBLE CAGE

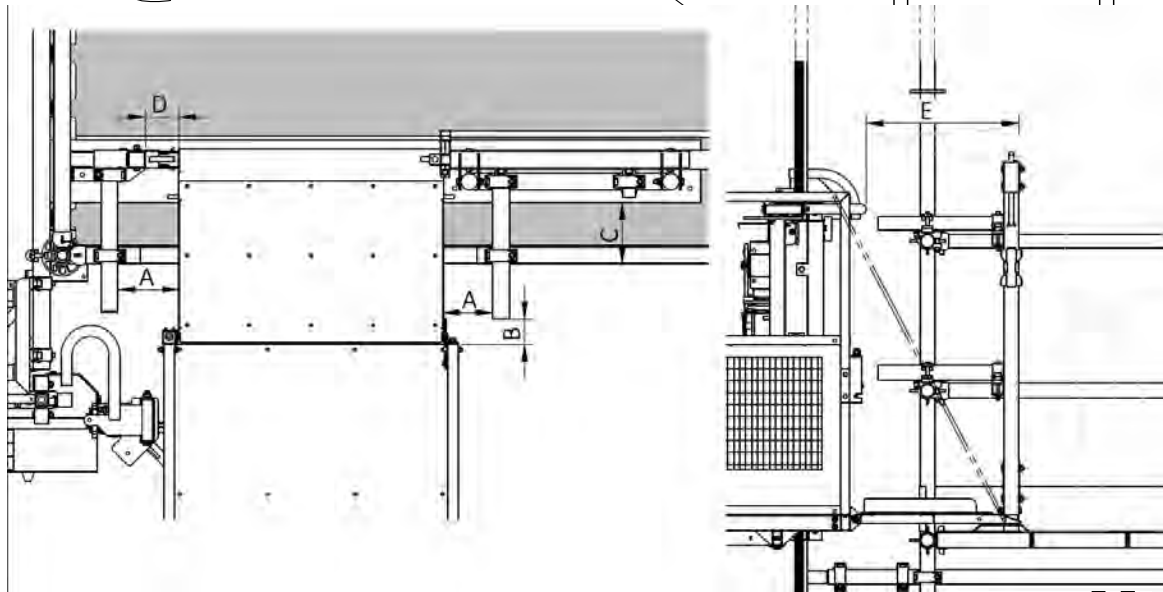
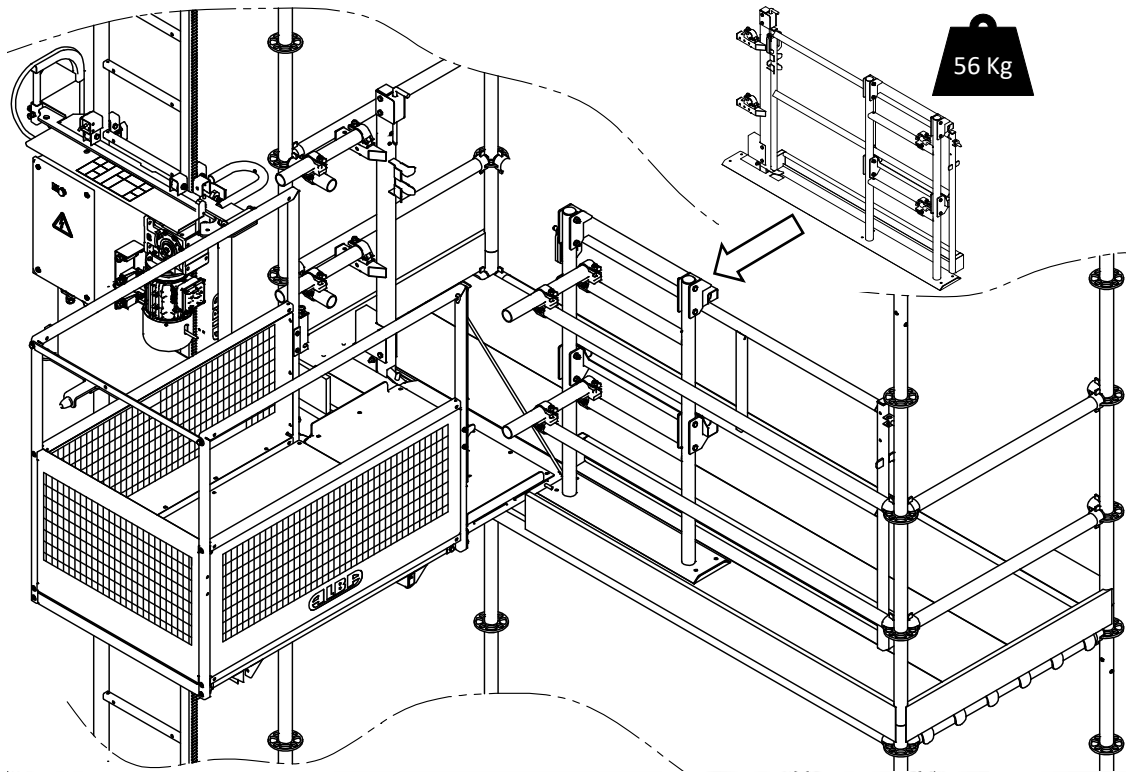

INSTALLATION DISTANCES	
A	< 150 mm.
B	< 150 mm.
C	± 180 mm.
D	± 100 mm.
E	± 500 mm.

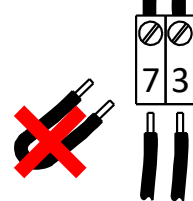
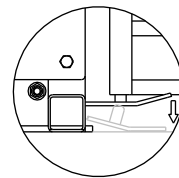
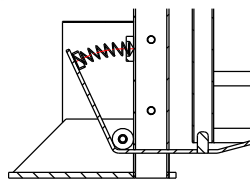

LANDING DOOR LOCK-SYSTEM

SWITCH CONNECT.



WARNING:
IT IS FORBIDDEN TO USE THE ACCESIBLE CAGE WITHOUT LANDING DOORS. THE USER MUST VERIFY THAT THERE IS NO GAP WITH A RISK OF FALLING IN THE LOADING AND UNLOADING AREAS.

2.6 Dismantling the hoist

For the dismantling of elevator perform the reverse process to that described in this manual, with particular attention to the tasks that present a risk of falling.



ATTENTION:

FOR THE DISASSEMBLY OF THE MACHINE, THE INSTRUCTIONS FOR ASSEMBLY AND USE OF THE ELEVATOR MUST BE FOLLOWED, AND IT MUST ALWAYS BE CARRIED OUT BY AUTHORIZED TECHNICAL PERSONNEL.



ATTENTION:

IMPORTANT NOTE ON COMPLIANCE WITH EUROPEAN DIRECTIVE 2006/42/CE.

CE DECLARATION OF CONFORMITY is valid only for machines purchased and installed with all original components supplied by CANOPY BRANDS EUROPE, S.L.U. and following all the instructions provided in this user's manual, ensuring compliance with all SSER Annex I of Directive 2006/42/EC.

Otherwise, the machine can't be put into service until final assembly is declared in accordance with the specifications of Annex II of the Directive.

3. USING THE MACHINE.

3.1. Introduction.

The hoist has a point of control exclusively connected to base level panel. All the movements shall be performed with hold-to-run button.



WARNING:

**HOIST CAN ONLY BE USED BY THE DESIGNATED PERSONS, WHO HAVE BEEN INSTRUCTED IN THE SAFELY HOIST OPERATION.
IN THE CASE OF USING ACCESIBLE CAGE, ACCESS TO HOIST FOR LOADING OR UNLOADING IS ONLY ALLOWED TO INSTRUCTED PERSONNEL.**

3.2. Using the pendant hold-to-run control

Use the portable control panel from a position in which you have visual access to the full hoist railway.



WARNING:

IT IS FORBIDDEN TO OPERATE THE HOIST IF YOU DO NOT HAVE VISUAL ACCESS TO THE ENTIRE LIFT TRAVEL.

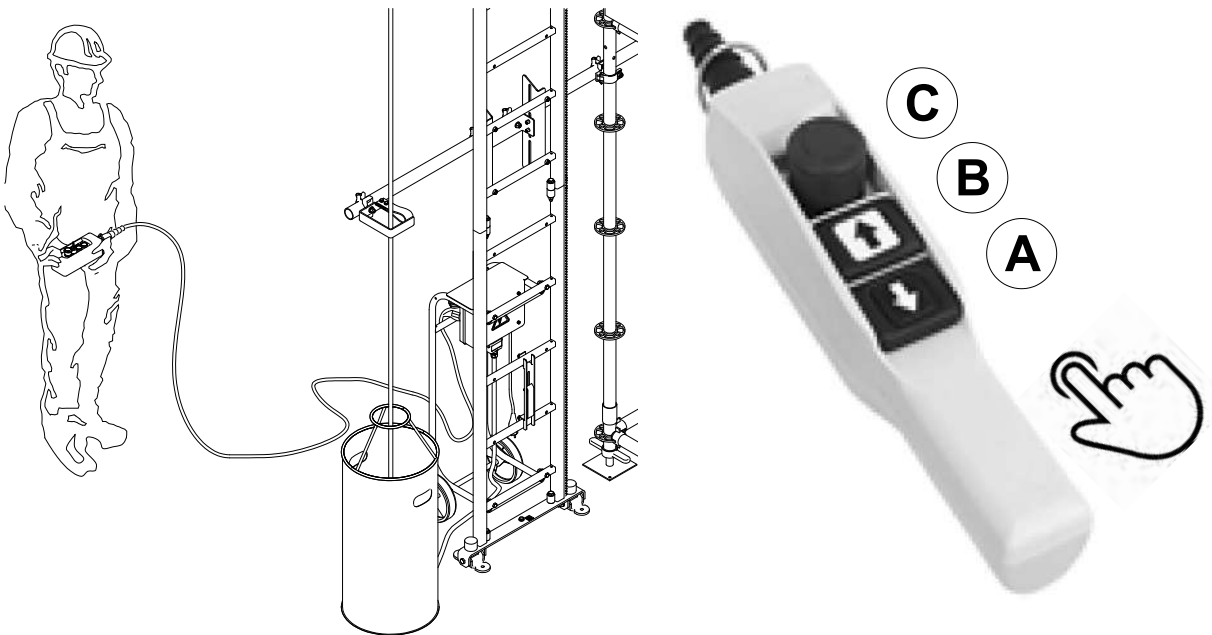

PORTABLE CONTROL PANEL. (A) RAISE (B) DESCENT (C) EMERGENCY STOP

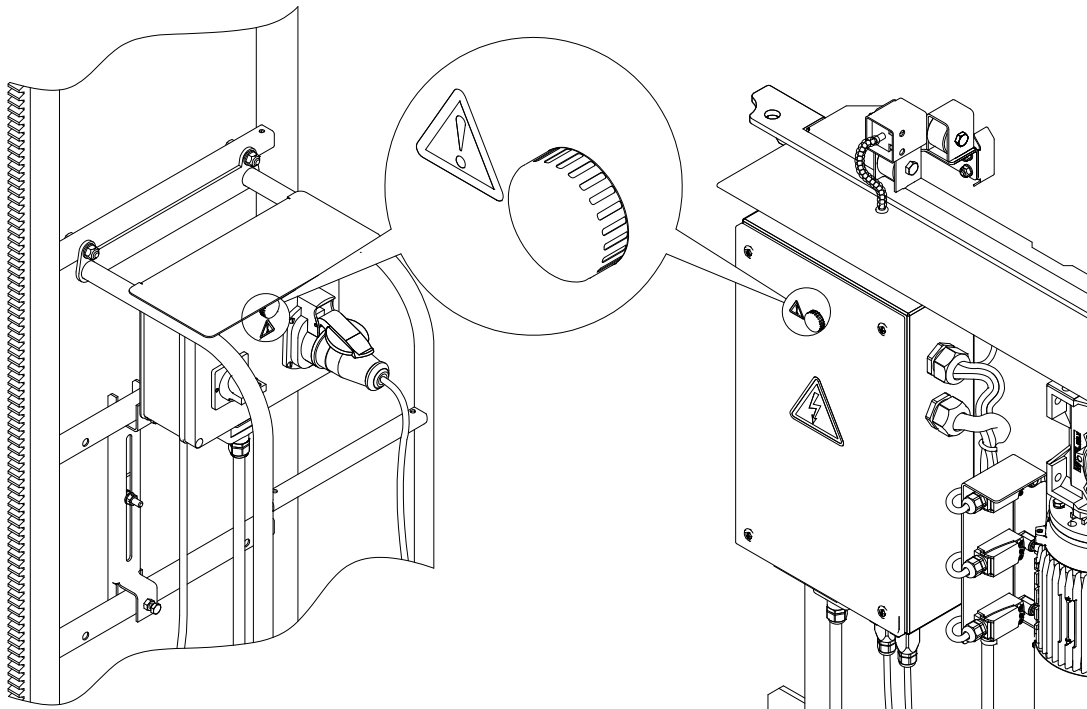

OUT OF SERVICE RED LIGHT

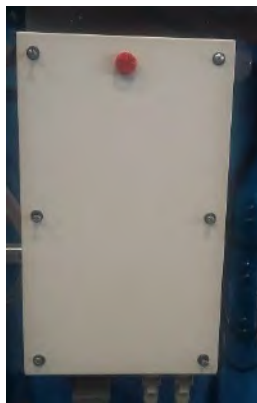

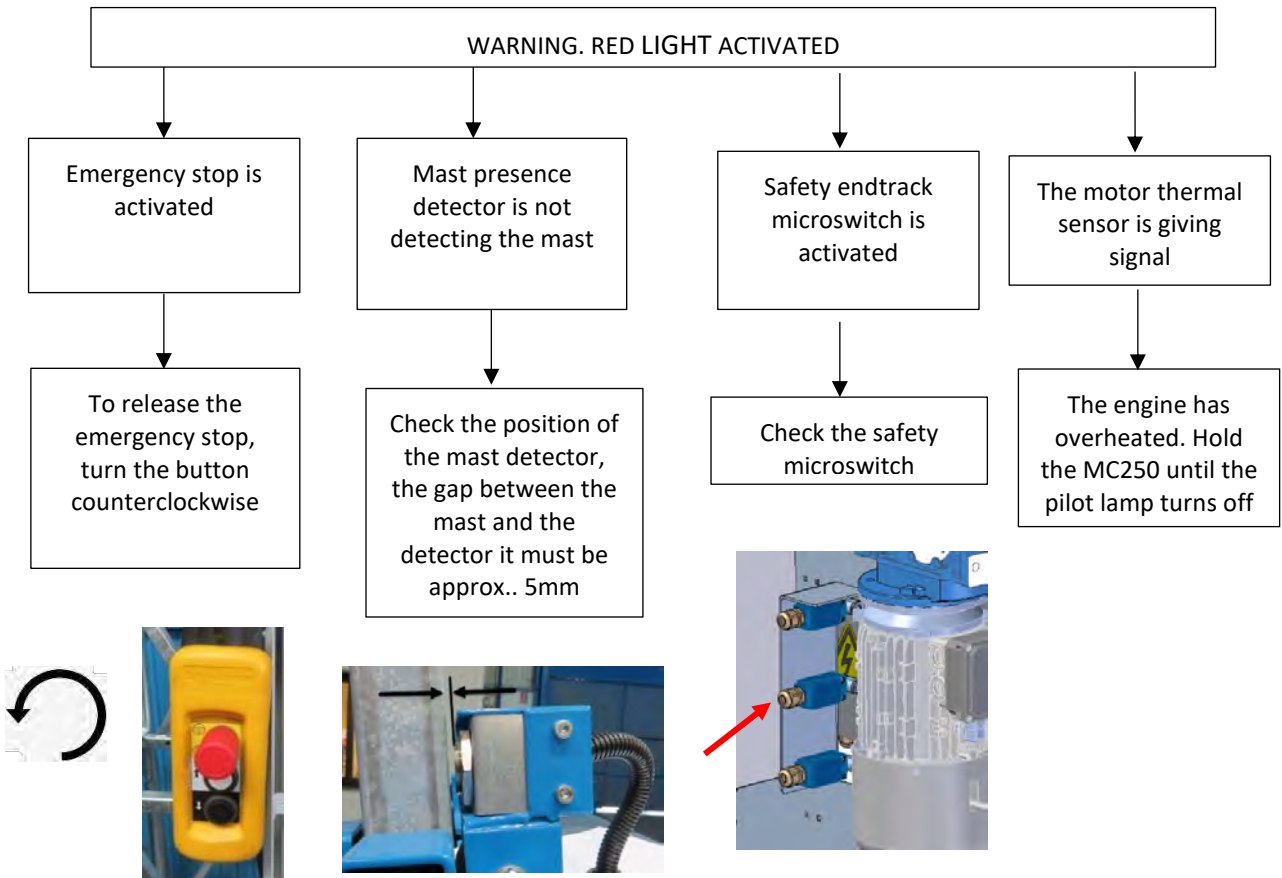

POINTS OF REVIEW IN CASE OF ACTIVATION OF RED LIGHT:

- 1 EMERGENCY STOP (C)
- 2 MAST PRESENCE DETECTOR (Chapter 1.6, N°4)
- 3 CAGEDOOR MICROSWITCH (IF ACCESSIBLE CAGE INSTALLED)
- 4 90°- TURNING CAGE MICROSWITCH (IF ACCESSIBLE CAGE INSTALLED)
- 5 SAFETY ENDTRACK MICROSWITCH (Chapter. 1.6, N°2)
- 6 MOTOR THERMAL PROBE (Chapter. 1.6, N°7)

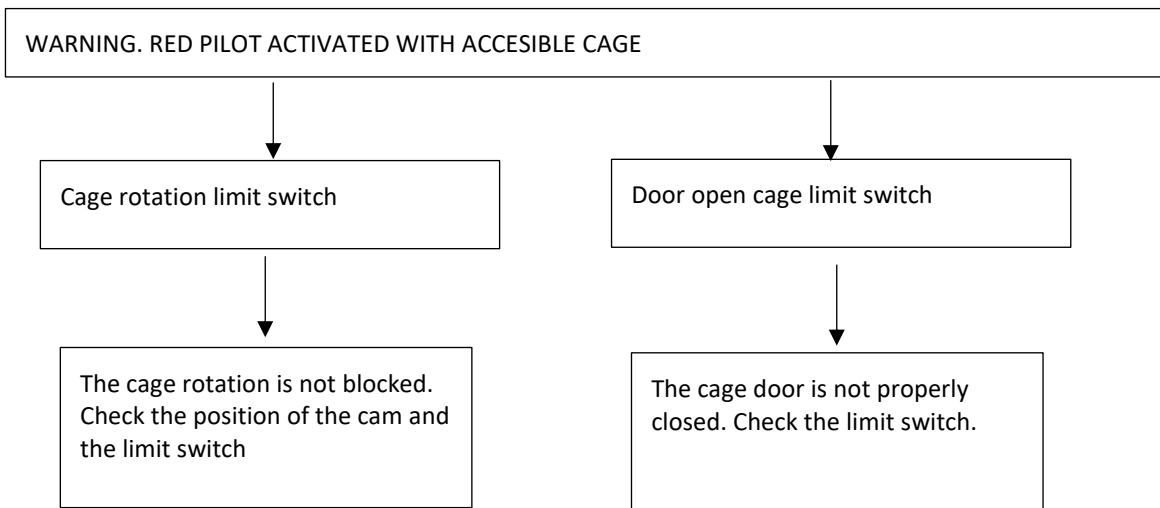

If the accessible cage is mounted, there are other points that we must check if the red light comes on:





WARNING:
IN CASE OF ACTIVATION OF THE RED LIGHT, CHECK THE SAFETY SYSTEMS INDICATED IN THE PREVIOUS TABLE. ONCE THE FAULT IS SOLVED, THE CONTROL AUTOMATICALLY RESETS.

3.3. Emergency lowering.

In case of power failure without the possibility of restoration, you can descent the cage handpicked, on the release levers of the motor brake. This must be done in small intervals to avoid machine acceleration.



WARNING:

THE OPERATOR SHOULD MOVE THE LEVER SMOOTHLY SO THAT THE EMERGENCY LOWERING OCCURS SLOWLY. IF THE PARACHUTE ACTIVATION SPEED IS EXCEEDED, IT WILL LOCK, PREVENTING DESCENT.



EMERGENCY LOWERING PROCEDURE

3.4 Checking hoist operation before commissioning



IMPORTANT:

BEFORE HOIST COMMISSIONING, HOIST SERVICE RESPONSIBLE WILL CHECK IF HOIST IS IN COMPLIANCE WITH FOLLOWING POINTS:

- Hoist´s installed with all operational safety systems:
 - Portable control buttons work correctly
 - Upper endtrack switch stops hoist before reaching upper endtrack buffers.
 - Lower endtrack switch stops hoist before reaching base buffers.
 - Mast presence detector works correctly.
 - OUT OF SERVICE red light indicator works correctly.
- There´s no interference of hoist and external items, mast, ties, supporting structure.
- Inferior access area to the hoist is demarcated and protected properly.
- Hoist travel track is protected to avoid persons falling hazard.
- Door opening systems work properly.
- Accessible cage: the limit switches of cage and landing doors work correctly
- Accessible cage: the limit switch of the cage rotation works correctly
- Accessible cage: landing doors are installed and working properly



**IMPORTANT:
KEEP ORDER AND CLEANING IN THE ELEVATOR AND SURROUNDINGS**

3.5 Forbidden ways of use

- DON'T use the hoist on explosive atmospheres.
- DON'T use the hoist with higher load than shown in the plate.
- Load CAN'T be piled up at the cage floor bounds, **it must be located as near mast as possible.**
- DON'T transport loads out of cage.
- DON'T use the hoist in adverse weather conditions, rain, ice, snow.
- DON'T use the hoist in unacceptable physical condition, treatment of serious illness, under alcoholic drinks effects, or under stress or mental overload condition.
- DON'T use the machine with other parts than those originals from the manufacturer.
- DON'T work without the necessary personal protection gear. These safety devices will vary upon different conditions, therefore, a qualified person in the requirement of safety and health must evaluate the working conditions and mode of use before starting works.
- DON'T leave the control panel opening key to anyone other than the maintenance person or other qualified person.
- DON'T dismantle integrated equipment whose maintenance is only allowed authorized personnel (i.e.: electrical motor, brake, gear-reductor).
- DON'T manipulate electrical system without express permission of the manufacturer.
- DON'T use the hoist without a differential switch on the main power supply connection line.
- DON'T use the machine under insufficient lighting conditions. If necessary, local lighting will be installed at access points, illuminating the hoist way.
- DON'T use the hoist with people travelling on the cage (Special cases, ask the manufacturer)

4. SAFETY DEVICE. PARACHUTE FPC-500

4.1. Introduction

According to the specifications of Directive 2006/42/EC, the hoist must have a safety device for mechanical locking to act if the speed exceeds a set value. The parachute safety system is a mechanical unit designed to prevent accidental loss of the machine. The system only operates during the fall, when the speed exceeds a predetermined value, acting as a hoist speed tracker, not making any effort on lifting device, during normal operation of the machine.

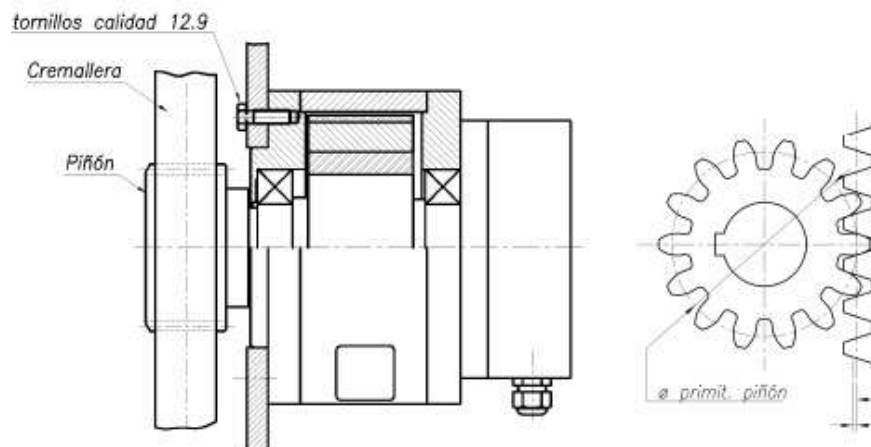

ASSEMBLY OF PARACHUTE. GENERAL DESIGN

4.2. Features:

A parachute works by blocking the drop in the case of there is a speed rising over the nominal value. The overspeed detection system is based on the principle of action of the centrifugal force to engage driven pinion into the elevator structure. On the elevators there are two intermediate crowns as parachute pinion and rack transmission. Its main components are as follows:

- **Cover:**

The parachute has waterproof housing that allows confining the security unit, preventing it from dust and corrosive atmosphere inside. It must also prevent unauthorized adjustment, so that screws should not be handled by unauthorized persons.

- **Buffer:**

The parachute has a progressive braking system so that locking is produced in a buffered way, so that after a controlled braking, the cage is stopped, according to deceleration specifications of reference standards to avoid accidents resulting from major efforts generated by moving mass inertia.

• **Locking:**

The device features a brake consisting of four sectors, which are charged up to torque referred to the elevator, so that deceleration is controlled accurately, even in case of free drop of the machine, according to the specifications of harmonized standards reference.

• **Integrated microswitch:**

The parachute includes a microswitch that is activated in case of brake locking, allowing the signal to cut the movement of hoist and preventing further operations of the machine, until the action of a person designated to release the hoist.

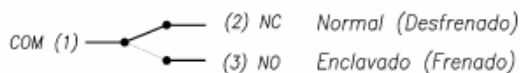
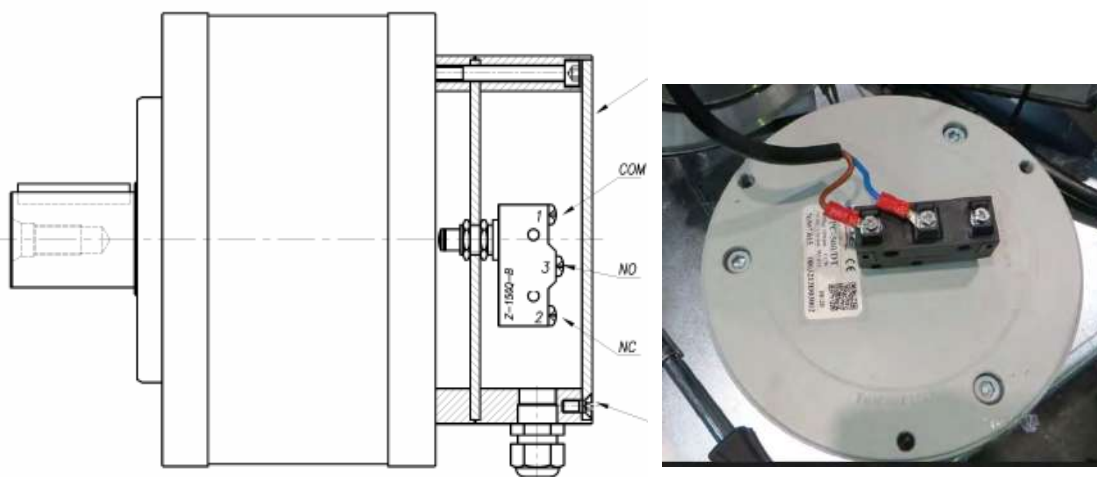

SAFETY SWITCH AND INTERNAL CONNECTION

• **ID plate and features of the device:**

The parachute is equipped with an identification plate, with CE logo stamped and brake characteristics:

- Brake type, mounting position and lock sense.
- Locking speed (r.p.m.) and brake torque (N·m)
- Number, date and reference of manufacture.



ID PLATE EXAMPLE ON THE PARACHUTE

4.3. Installing the parachute

The unit shall be rigidly fixed to the chassis of the cage, so that the pinion is centred with the hole, to rotate at the speed of normal movement of the elevator. The unit must be fitted to the hoist with all screws and safety washers.

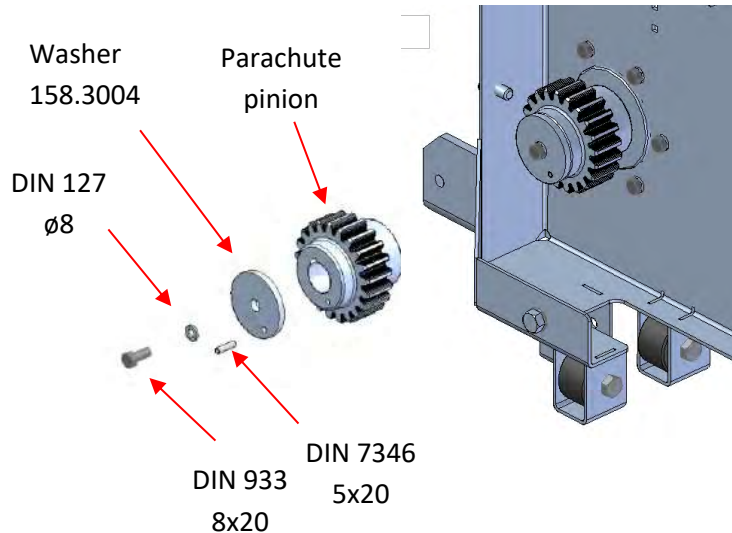

INSTALLING SAFETY UNIT IN TO THE HOIST



WARNING:
DON'T INSTALL A PARACHUTE IN A HOIST WITH OTHER FEATURES THAN THOSE MARKED IN THE PLATE



WARNING:
HANDLING AND TESTING OF THE PARACHUTE ONLY IS ONLY ALLOWED TO THE MANUFACTURER OR AUTHORIZED SERVICE PERSONNEL.

Finally, install the safety switch wire on its correct position, according to the scheme, to avoid further movement of the hoist if the safety device locks, until the actuation of technical personnel.

Once the assembly of the unit is finished, install back cover, so the device remains watertight and mechanical characteristics of the parachute are preserved along the time. Nobody but the manufacturer is allowed to manipulate screws of the unit itself.

4.4. Parachute drop test.

4.4.1 Manufacturer test.

ALBA performs a test on each lift during the machine assembly to ensure the safety and proper functioning of the device. The test result is reflected in the TEST CERTIFICATE, which accompanies this manual of the machine.

4.4.2 Test during use.

Periodically, **every 4 months**, or **after each assembly machine on site**, a functional test of the parachute shall be performed, in accordance with the instructions set out below. The test of the parachute must be further supplemented with a brake inspection, checking the correct appearance of all the elements and the sealing of the outer cover. This process is repeated more often if the machine operates in extreme environmental conditions.



CARRY OUT A PARACHUTE DROP TEST AT THE END OF EACH ASSEMBLY, AND THEN REPEAT PERIODICALLY EVERY 4 MONTHS. WRITE THE RESULT IN THE USERS'S MANUAL RECORD.

PARACHUTE TEST PROCEDURE:

- 1.- Open the terminal box and release the motor connectors (in single phase units)

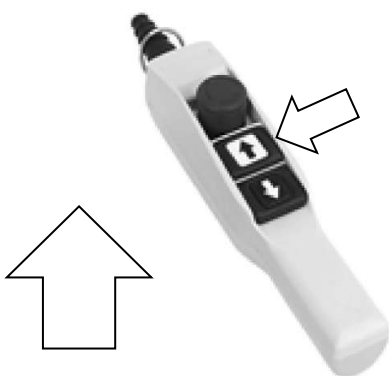
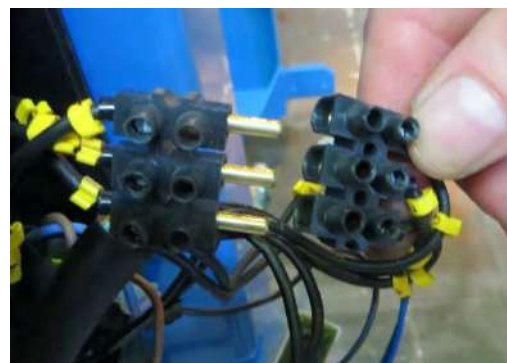
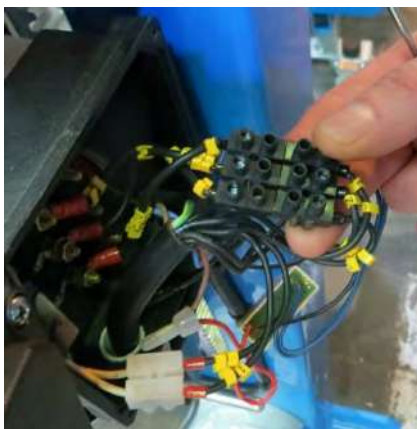

RAISE THE HOIST ($\pm 1,5$ m.)

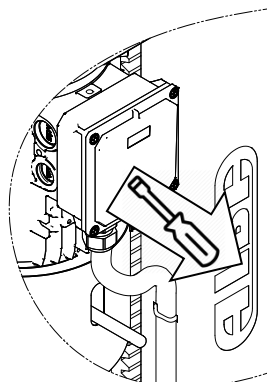

OPEN MOTOR BOX

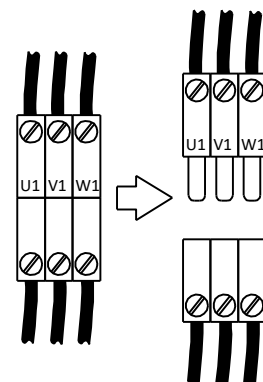

RELEASE MOTOR CONNECTOR

2.- Raise the hoist approximately 1,5m.

3.- Tie a cable to the brake lever and pull it diagonally, always out of travel track of the hoist. Pull the cable by dropping the lift until the parachute activates and the machine stops.

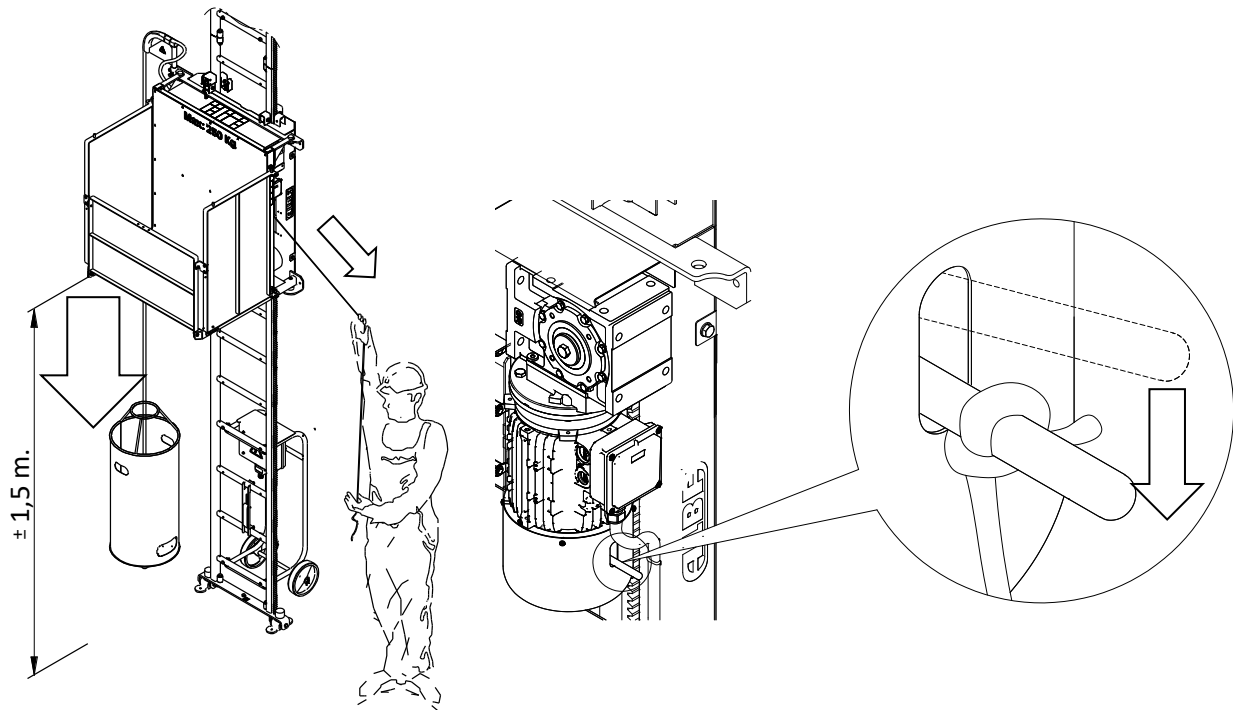



IMPORTANT:
VERIFY THAT THE OPERATOR IS NOT WITHIN REACH OF THE HOIST BEFORE PULLING THE LEVER. STOP THE TEST IF THE PARACHUTE DOES NOT ACTIVATE BEFORE REACHING THE LOWEST POINT AND REPEAT THE TEST INCREASING THE HEIGHT.

4.- Check if the parachute is activated pressing the down button on the pendant control.

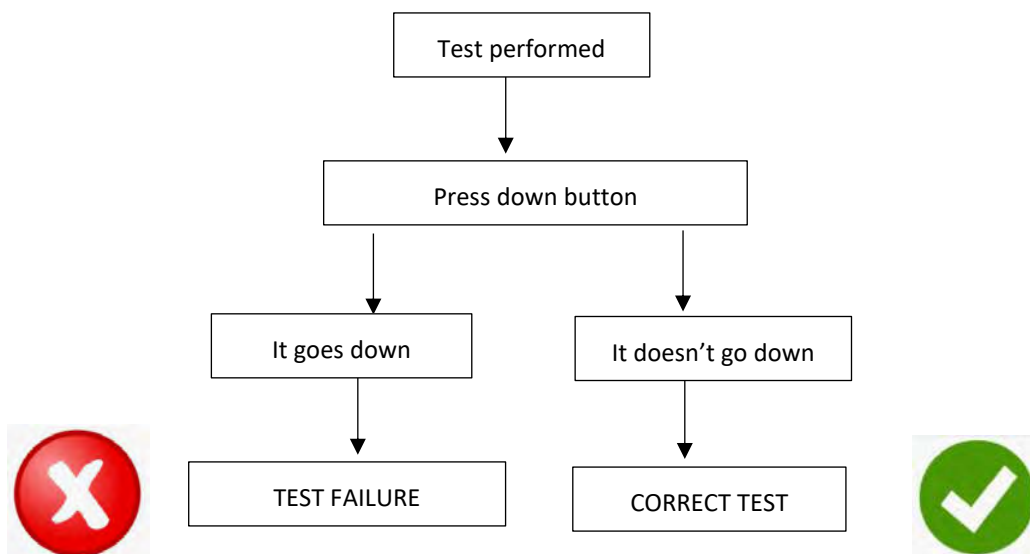



IMPORTANT:
 IF THE TEST IS INCORRECT, THE PROCESS MUST BE REPEATED FROM THE BEGINNING.
 IF THE TEST IS CORRECT, THE RESULT WILL BE RECORDED IN THE MAINTENANCE LOG.



IMPORTANT:
 WHEN THE PARACHUTE IS ACTIVATED THE HOIST CANNOT GO DOWN.

5.- Raise the hoist with pendant control and stop it at approx. 3 m above the ground.

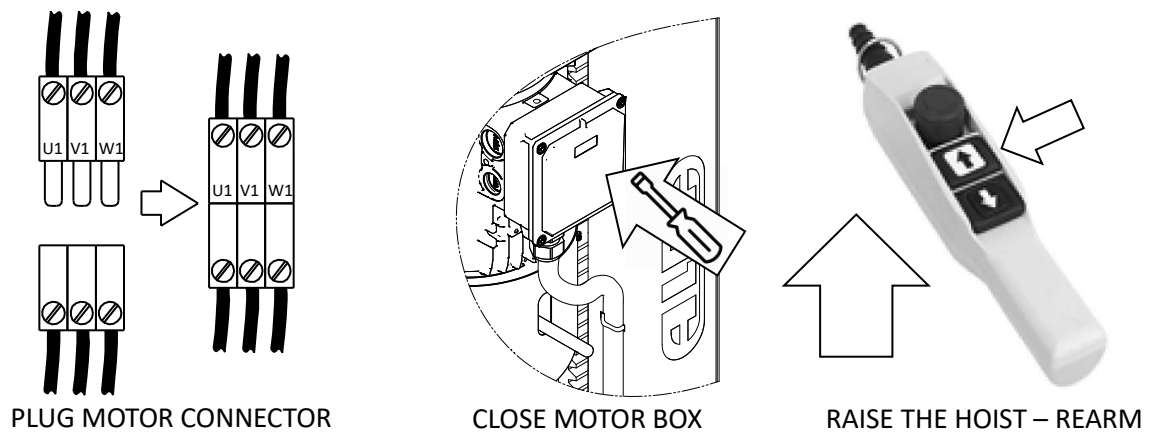

4.4.3 Actions to take if safety device is activated.



ATTENTION:
 THE PARACHUTE IS AUTOMATICALLY REACTIVATED BY BRIEFLY PRESSING THE RAISE
 BUTTON. THE HOIST IS READY FOR SERVICE AGAIN.

The parachute is activated in case that the emergency lowering speed exceeds predetermined speed. This can only happen if we are testing the parachute or in the following cases:

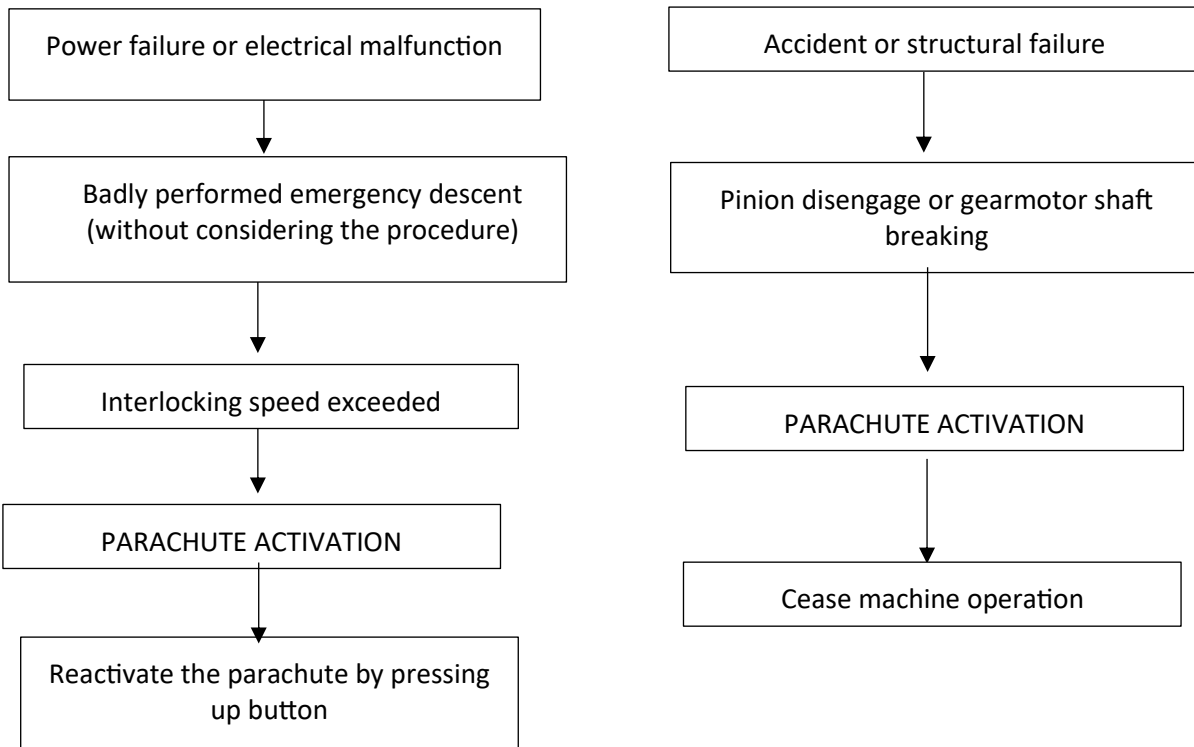
ATTENTION:

IN CASE OF ACCIDENT OR ESTRUCTURAL FAILURE CEASE MACHINE OPERATION UNTIL THE ACTION OF AN AUTHORIZED TECHNICIAN. IF THERE IS NO CLEAR SOLUTION, PERFORM THE DISASSEMBLY OF THE MACHINE WITH AUXILIARY MEANS.

4.5 Replacement of the parachute

Following the instructions of the safety device manufacturer, to ensure integrity of the device, along the time, parachute shall be replaced after **6 YEARS** from the date of installation on the hoist. See installation plate.

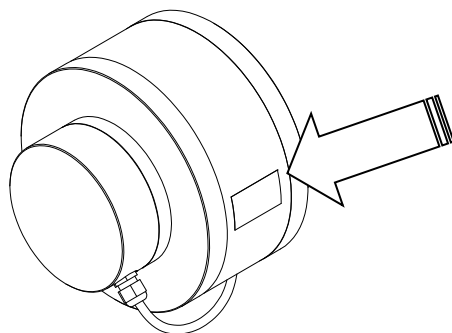

Fecha de instalación:	Installation date:	01 -2025
Date de installation:		
Fecha de sustitución:	Replacement date:	01 -2031
Date de replacement:		

INSTALLATION AND REPLACEMENT PLATE

· For more information: <https://www.eide.net/en/productos/fpc-overspeed-safety-brake/>

IMPORTANT:

AFTER REPLACEMENT OF THE PARACHUTE, DROP TEST OF THE NEW DEVICE MUST BE PERFORMED. WRITE THE RESULT IN THE USER'S MANUAL LOG.

5. MAINTENANCE OF THE MACHINE.

**WARNING:**

BEFORE PERFORMING ANY MAINTENANCE ACTION, TURN THE POWER OFF AND IF REQUIRED, BLOCK VERTICAL MOVEMENT AT LEAST 1.8 m. HEIGHT UNDER THE CAGE. MAINTENANCE TASKS MUST BE PERFORMED WITHOUT LOADS.

5.1. DAILY Maintenance.

Daily maintenance includes basic operations of visual inspection in the hoist, performed by the person responsible of the hoist on site. Every day, prior to use, visual inspection of the elevator should be done, according to the following service points:

- There's no accumulation of ice, snow, built-up of building materials or waste under the platform or surroundings.
- There's no excessive wear in the rack, or in the vertical pipe of the mast.
- All the protections and guards are installed, and there's no dangerous holes or gaps.
- Load placards, warning stickers, markings and operating manual are present for the hoist.
- Zone below hoist is bounded and base fence is installed.
- There isn't any warped or cracked part (Case of, change it).
- Electrical wires are correctly installed and tightly guided on the hoist.
- Guide rollers are in touch with mast tube and without excessive wear.
- There are no power lines near the hoist that endanger people or machine.
- There are no outgoing elements in the façade, or external obstructions that may interfere with the free movement of the machine.
- Electrical safety devices are operational (doors, end track switch, mast sensor).
- Emergency stop works properly.
- Anchorages are correctly installed.
- Rack-pinion transmission is correctly engaged.
- Control and power boards are in good condition
- All the controls, panels and indicators work properly.
- Cable travels and slides over the cable holder properly.

After reviewing all the checkpoints listed, by visual inspection, or by performing short up and down test movements without load, and solved any problem if required, the machine can be used safely.

5.2. Periodic maintenance schedule

Maintenance of the lift must be performed by a COMPETENT technical person responsible for the machine, and the results must be recorded on the MAINTENANCE RECORD.



WARNING:
IN CASE OF ELECTRICAL MALFUNCTION IN THE HOIST, DO NOT HANDLE ELECTRICAL EQUIPMENT. MAINTENANCE AND INSPECTION OF THE HOIST ONLY MUST BE PERFORMED BY AUTHORIZED PERSONNEL.



MAINTENANCE TASKS SCHEDULE

	ELEMENT	OPERATION / TOOL	PERIODICITY
1  VISUAL CHECKING	CONTROLS, UPPER/LOWER STOP LIMITS	CHECK FUNCTION	40 h WORK (MONTHLY)
	MAST DETECTOR	CHECK DISTANCE ±5 mm	
	GEARMOTOR OIL LEVEL	CHECK LEVEL	
	CONTROLS, EMERGENCY STOP, LIGHTS	CHECK OPERATION	
	MAST TUBE	WEAR, EROSION OR WELDING	
	MOTOR BRAKE RECTIFIER	CHECK OUTPUT VOLTAGE	
	COMMUNICATION CABLE	CHECK STATUS	
	GUIDE ROLLERS AND BASE BUFFERS	VISUAL CHECKING	
	ANCHORAGE	CHECK INTERFERENCE	
	PLACARDS, DECALS, WARNINGS, MARKS	CHECK PRESENCE	
SAFETY SWITCHES AND INTERLOCKS	CHECK OPERATION		
2  GREASING	MAST RACK	LITHIUM GREASE	40 h WORK (MONTHLY)
	GEARMOTOR PINION	LITHIUM GREASE	
	PARACHUTE PINION	LITHIUM GREASE	
3  TIGHTENING	MAST CONNECTING BOLTS	SCAFFOLD RATCHET SPANNER	QUARTERLY 4 TIMES/YEAR
	ANCHORING SCREWS	SPANNER	
4  MEASURING	GUIDE ROLLERS DIMENSIONS	MEASURE WITH CALIBER	ANNUAL (OR AFTER DISMANTLING)
	RACK DIMENSION	MEASURE WITH CALIBER	
	GEARMOTOR PINION STRING	MEASURE WITH MICROMETER	
	MOTORBRAKE AIRGAP CHECKING	MEASURE WITH GAUGES	
5 GENERAL INSPECTION	MAST	DEFORMATION OR DAMAGE	After disassembly or after periods of non-use
	ANCHORAGES	DEFORMATION OR DAMAGE	
	DOORS, HANDRAILS, FLOORS	DEFORMATION OR DAMAGE	
	GEARMOTOR AND BRAKE	CHECK RECTIFIER, VOLTAGE AND COIL RESISTACE	
		CHECK OIL LEVEL (*)	

(*) Only if required, see p.56

MAINTENANCE CHECKING TABLE

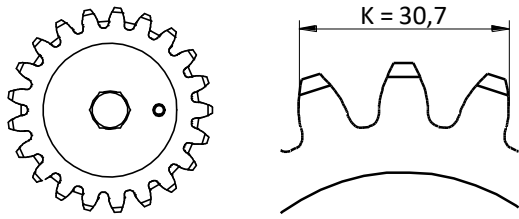

CONTROL DIMENSION K [mm]		
	Nom.	Min.
PINION Z21	30,7	28
PINION Z21	30,7	28

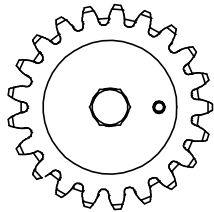

OVERLAP \square [mm]		
	Nom.	Min.
\square	8	5,4

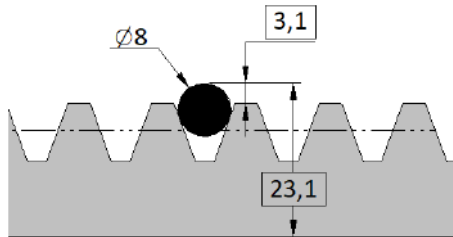
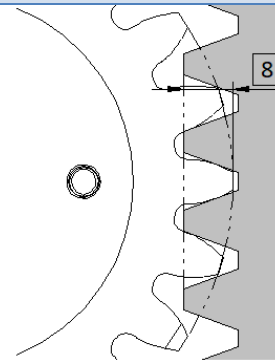

CONTROL DIMENSION \square [mm]		
	Nom.	Min.
\square A	3,1	2
\square B	23,1	22

CHECKING RACK AND PINION WEAR

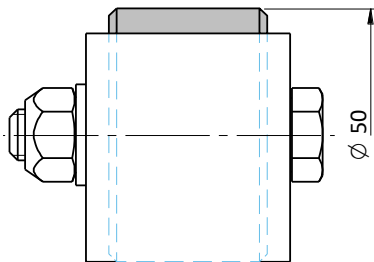

CONTROL DIMENSION \varnothing [mm]		
	Nom.	Min.
\varnothing	50	48

MAST GUIDE ROLLERS COMPROBATION

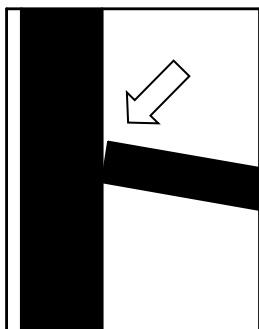

CHECKING MAST WEAR AND DAMAGE

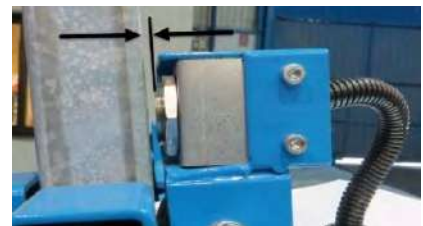
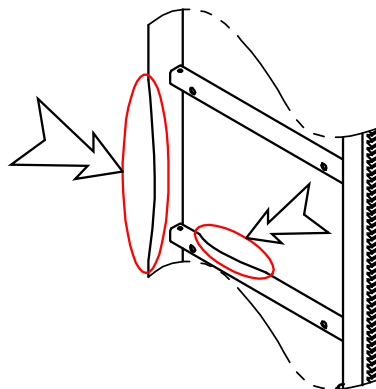

CHECKING MAST DETECTOR



ATTENTION:

ENSURE ROLLER'S WEAR IS UNIFORM ALONG THE CONTACT'S CIRCUMFERENCE



ATTENTION:

CHECK FOR POSSIBLE DAMAGES AND EXCESSIVE WEAR ON MASTS BEFORE AND AFTER ERECTION TAKEN INTO ACCOUNT PERIODICITY INDICATED

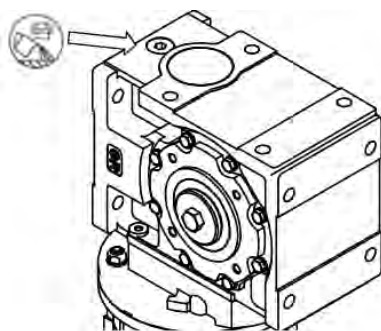

Properties			Method	Shell Omala S4 GXV 220
Kinematic Viscosity	@40°C	mm ² /s	ASTM D445	220
Kinematic Viscosity	@100°C	mm ² /s	ASTM D445	30
Viscosity Index			ASTM D2270	171
Flash Point (COC)		°C minimum	ASTM D92	240
Pour Point		°C	ASTM D97	-42
Density	@15°C	kg/m ³	ASTM D4052	864
Four Ball EP Weld load		kg minimum	ASTM D2783	250
FZG Load Carrying Test		failure load stage minimum	A/8,3/90	14

MOTOR GEAR MAINTENENACE



IMPORTANT:

MOTOR GEARS ARE INSTALLED FILLED OF 220 SYTHETIC OIL FOR ITS LIFE-TIME LUBRICATION, IN ABSENCE OF EXTERIOR CONTAMINATION. REPLACE THE OIL IF NECESSARY. REPLACE WITH OIL ACCORDING TO THE GRADE INDICATED.



IMPORTANT:

MOTORGear OIL IS GOOD TO USE IN RANGE 0°C < T_a < 40°C WITH PEAKS -20°C < T_a < 50 °C. REPLACE OIL COMPLETELY. DO NOT MIX DIFFERENT OILS.

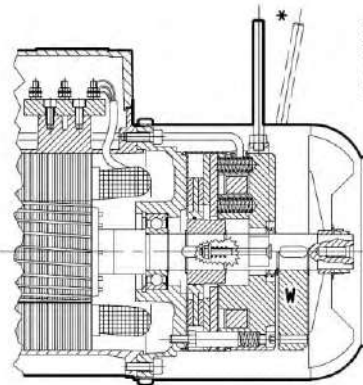
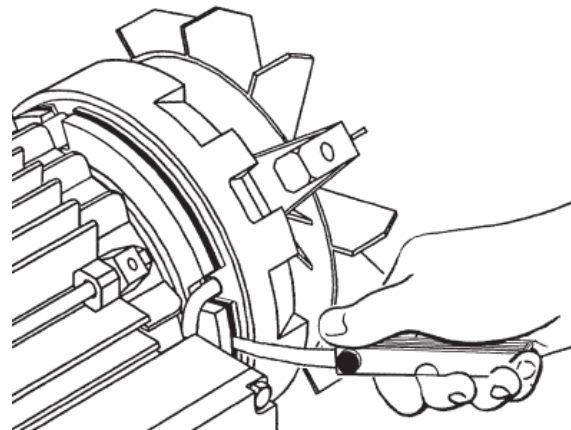
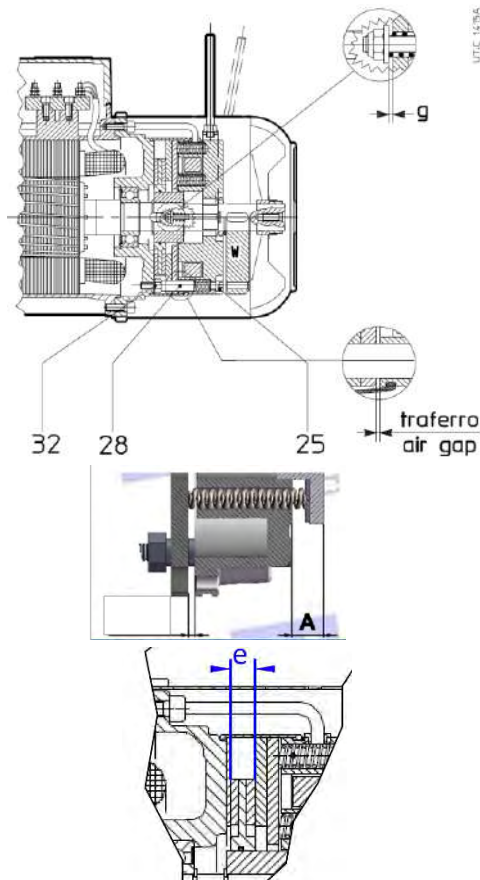
INSTRUCTION FOR MAINTENANCE OF ELECTRIC MOTOR-BRAKE

MOTOR BRAKE WITH D.C. BRAKE AND MANUAL RELEASE LEVER

SINGLE PHASE MOTOR: CONTROL MEASURES [mm]

	Nom.	Max.	Min.
Air gap	-	0,4	0,2
Brake disc thick.(e)	-	-	5,75

THREE PHASE MOTOR: CONTROL MEASURES [mm]

	Nom.	Max.	Min.
Air gap	-	0,45	0,30
Brake disc thick.(e)	-	-	7

BRAKE DISC ADJUSTMENT

IMPORTANT:

AIR GAP HIGHER THAN THE MAXIMUM VALUE MAY AFFECT BRAKE TORQUE. CHECK PERIODICALLY AIR GAP AND BRAKE DISC THICKNESS.

BRAKE ADJUSTMENT PROCEDURE:

1. Unlock nuts **No.32**, located on 3 positions spaced 120°
2. Tight fixation bolts **No.25** [in case of flywheel, act through the available holes] up to reach the minimum airgap measured in 3 positions spaced 120° with feeler gauges, as close as possible to guides **No.28**.
3. Tight nuts **No.32** keeping same position of fixation bolts **No.25**.
4. Check final airgap and compare with values indicated on table.



IMPORTANT:
AFTER SEVERAL AIR GAP ADJUSTMENTS, VERIFY THE BRAKE THICKNESS (e) IS NOT LOWER THAN MINIMUN INDICATED ON TABLE. REPLACE IF NECESSARY

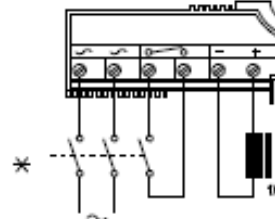
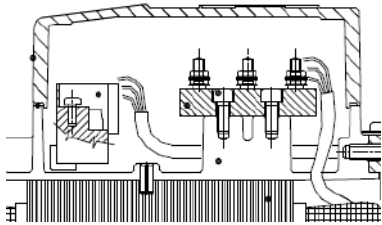

BRAKE'S D.C. SUPPLY RECTIFIER – THREEPHASE MOTOR

RECTIFIER CHECK TABLE

a) Vac power supply	(~ . ~)	230 Vac
b) Vdc power output	(- . +)	75 – 105 Vdc
c) Coil resistance (*)	(- . +)	±250 Ω

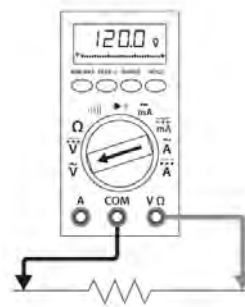
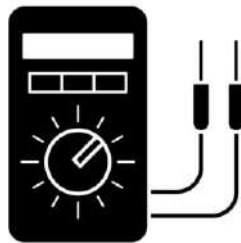

a) ~.~ ; b) - . +

c) Ω

RECTIFIER CHECKING – THREE PHASE MOTOR

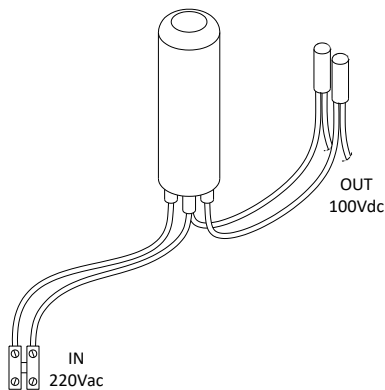

**RECTIFIER CHECKING
 (SINGLE PHASE MOTOR)**



**ADJUSTING BRAKE AIRGAP AND TORQUE
 (SINGLE PHASE MOTOR)**



IMPORTANT:
CHECK POWER INPUT/OUTPUT WITH HOITS WORKING TO ENSURE RECTIFIER FUNCTIONS. ATTENTION! ELECTRIC RISK.



IMPORTANT (*):
TO CHECK BRAKE COIL CONDITION, REMOVE SUPPLY CABLES FROM RECTIFIER (+, -) AND CHECK RESISTANCE READING ACCORDING TO PROCEDURE c). REPLACE IF NECESSARY.

5.3. Instructions for troubleshooting.

Problem	Probable cause	Solution
Hoist doesn't run (REL LIGHT ACTIVATED)	<ul style="list-style-type: none"> • Emergency stop activated • Safety endtrack limit switch activated • Cage door / Landing door / 90°-turning • Mast detector • Motor thermal probe 	<ul style="list-style-type: none"> • Check emergency stop. • Check safety microswitch FCSB. • Check doors and 90°-turning switches. • Check mast detector. • Check motor thermal probe .
Hoist moves doing abnormal noise or it doesn't smoothly	<ul style="list-style-type: none"> • Guide roller or bearing damaged • Lack of grease in mast rack 	<ul style="list-style-type: none"> • Check / replace guide rollers. • Apply grease to mast rack.
Hoist slides down when charging loads	<ul style="list-style-type: none"> • Brake doesn't work • Overload 	<ul style="list-style-type: none"> • Check / replace brake (disk, rectifier). • Check load on carrier.
Electric motor starts very slowly	<ul style="list-style-type: none"> • Brake rectifier doesn't work • Electric motor capacitors doesn't work • Power voltage failure 	<ul style="list-style-type: none"> • Check / replace brake rectifier. • Check / replace capacitors. • Check supply voltage.
Hoist doesn't stop in endtrack	<ul style="list-style-type: none"> • Problem in landing cams • Problem with motor brake 	<ul style="list-style-type: none"> • Check endtrack cams / endtrack switches • Check motor brake .
E1 or E2 shutting down	<ul style="list-style-type: none"> • Problem in transformer 	<ul style="list-style-type: none"> • Check / replace transformer.
Hoist carrier vibrates abnormally	<ul style="list-style-type: none"> • Non tightened screws • Rack – pinion gear problem • Lack of lubrication 	<ul style="list-style-type: none"> • Check and adjust guide roller screws. • Check rack – pinion gearing. • Apply grease to rack and pinion.
Gearmotor sounds / vibrates abnormally	<ul style="list-style-type: none"> •Lack of oil of gearmotor •Gearmotor bearing failure 	<ul style="list-style-type: none"> • Check oil level. • Alert motor technical service.
Hoist suffer stops when moving	<ul style="list-style-type: none"> •Communication cable damaged •Endtrack switch / door switch misadjusted 	<ul style="list-style-type: none"> • Check communication cable. • Check switches adjust.

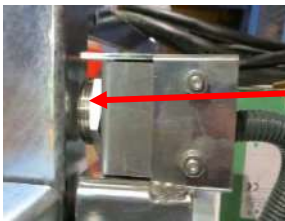

Mast presence detector

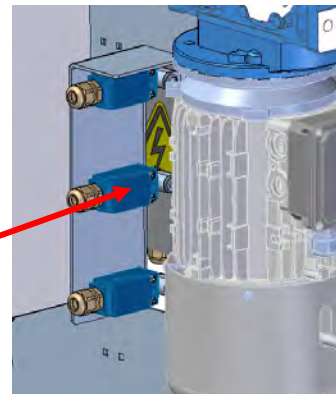

Safety endtrack microswitch

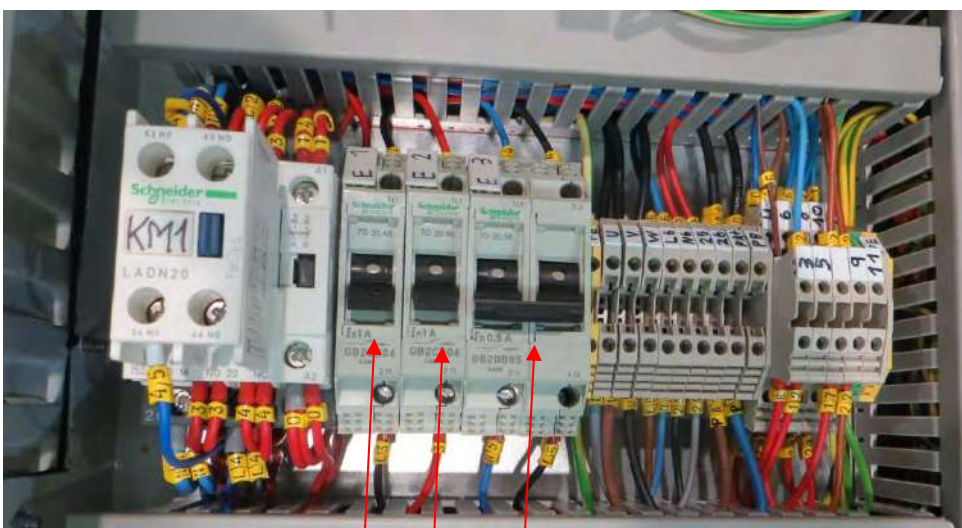

E1 E2 E3

ADDITIONAL INFORMATION FOR TROUBLESHOOTING

5.4. Maintenance record.

According to the procedure specified in the user's manual, the responsible for maintenance of the hoist should fill this table according to the frequency indicated, for the record of scheduled tasks.

No.	DATE	TASK DESCRIPTION	NAME	SIGNATURE
1				
2				
3				
4				
5				
6				
7				
8				
9				
10				
11				
12				
13				
14				
15				
16				
17				
18				
19				
20				
21				
22				
23				
24				
25				
26				
27				
28				
29				
30				
31				
32				
33				
34				
35				
36				
37				
38				
39				
40				
41				
42				
43				
44				
45				

No.	DATE	TASK DESCRIPTION	NAME	SIGNATURE
46				
47				
48				
49				
50				
51				
52				
53				
54				
55				
56				
57				
58				
59				
60				
61				
62				
63				
64				
65				
66				
67				
68				
69				
70				
71				
72				
73				
74				
75				
76				
77				
78				
79				
80				
81				
82				
83				
84				
85				
86				
87				
88				
89				
90				
91				
92				
93				
94				
95				

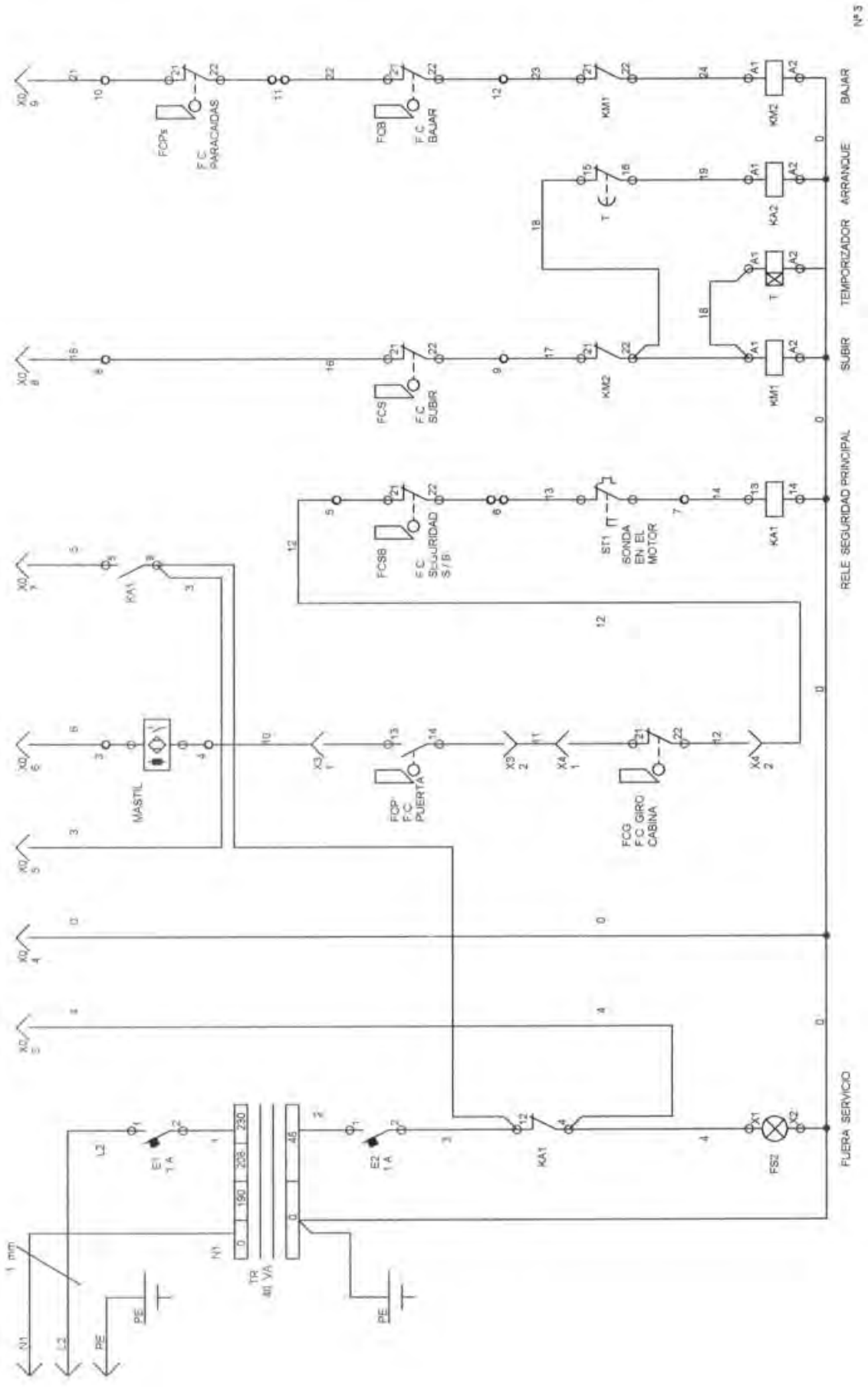

Nº 3

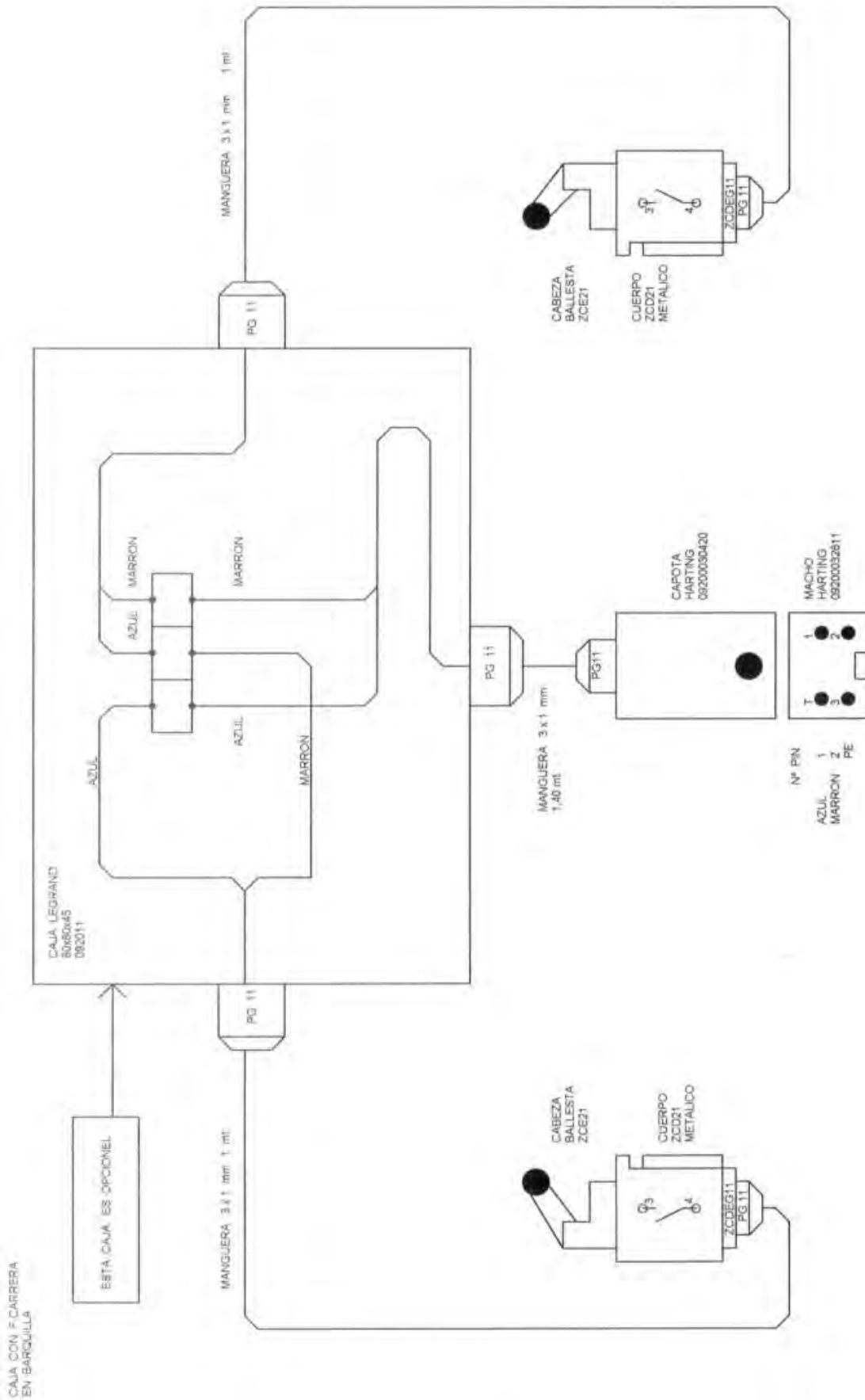

6.2. MC 250V single phase with inverter

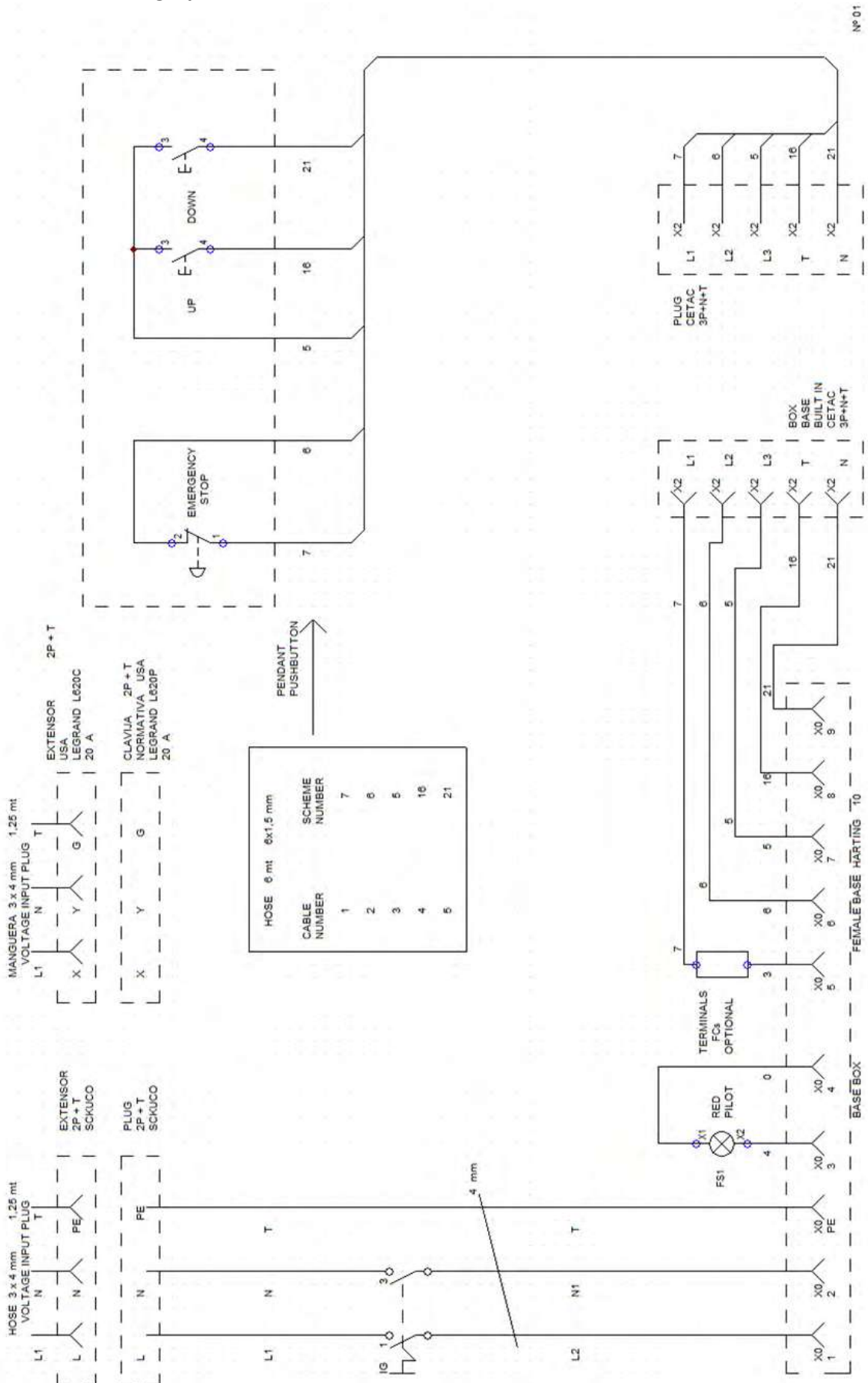

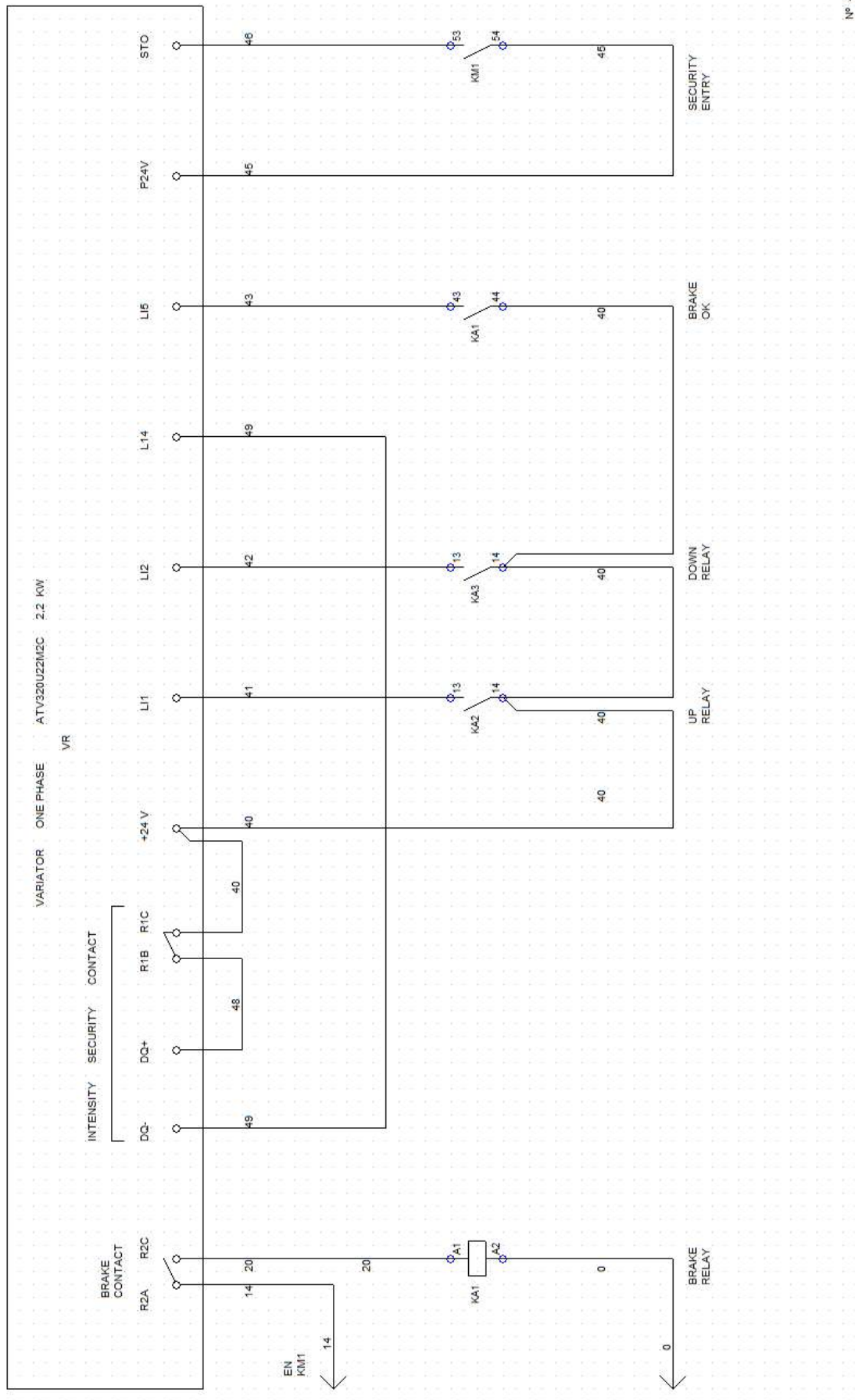

№ 4

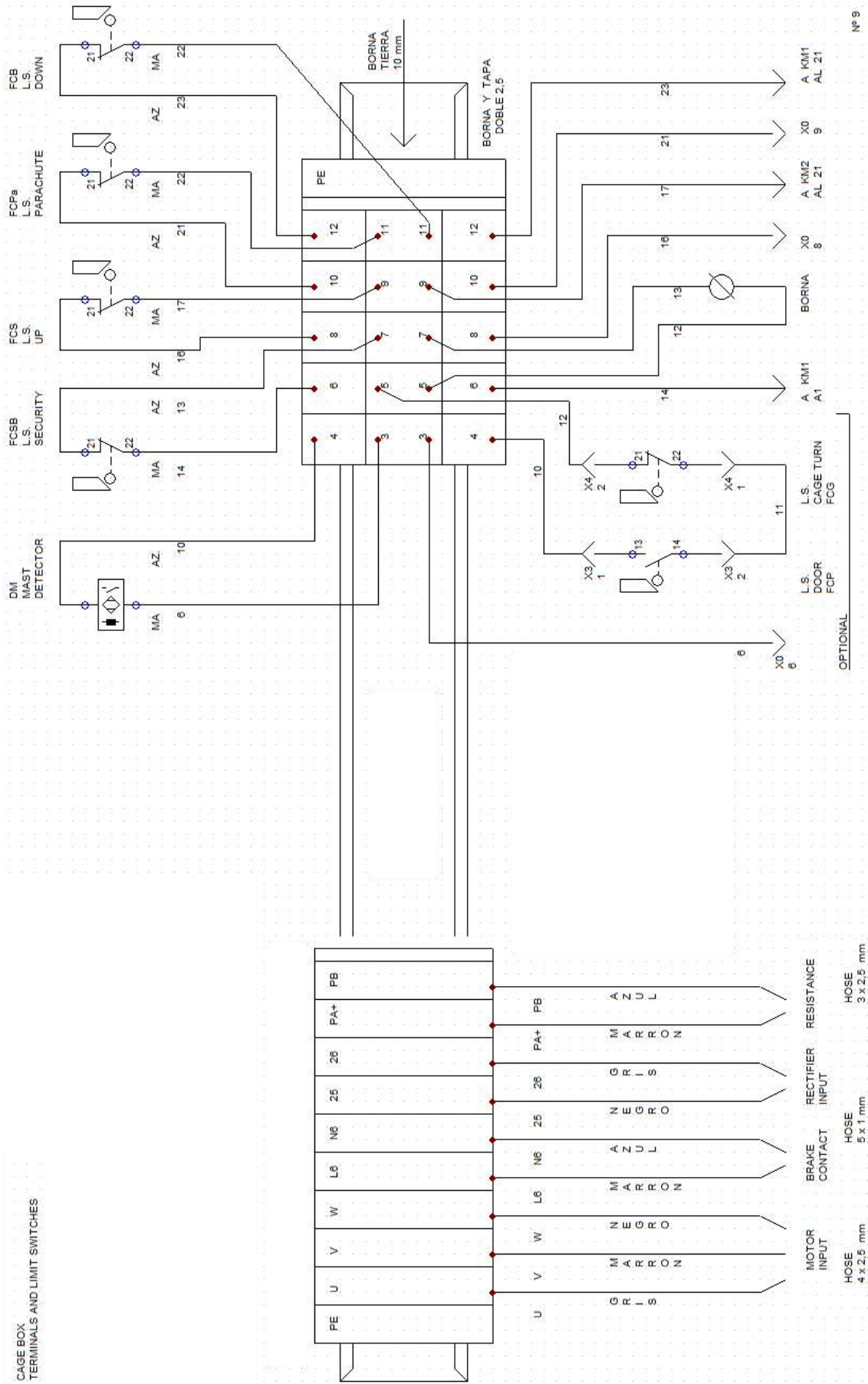

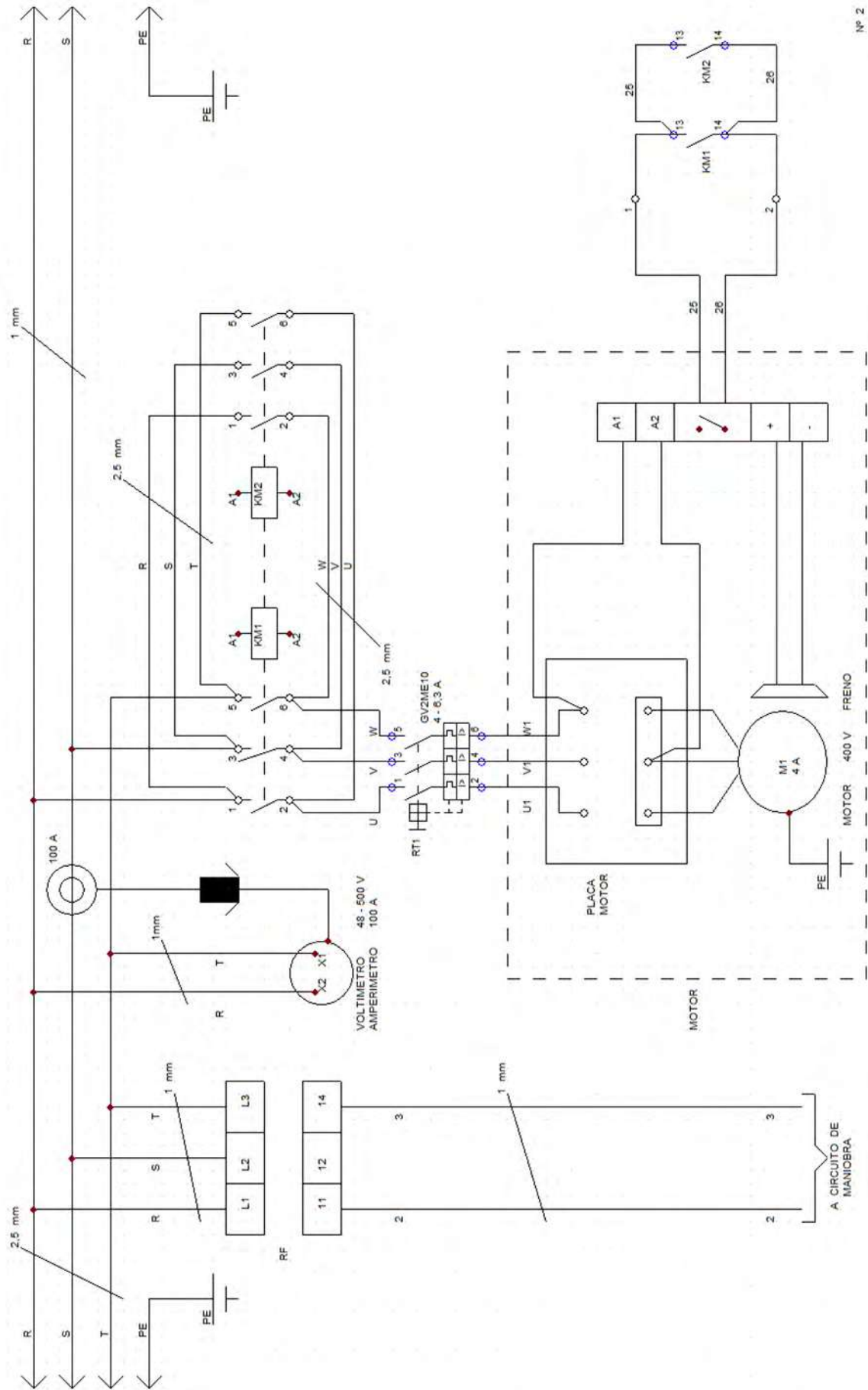

Nº 2

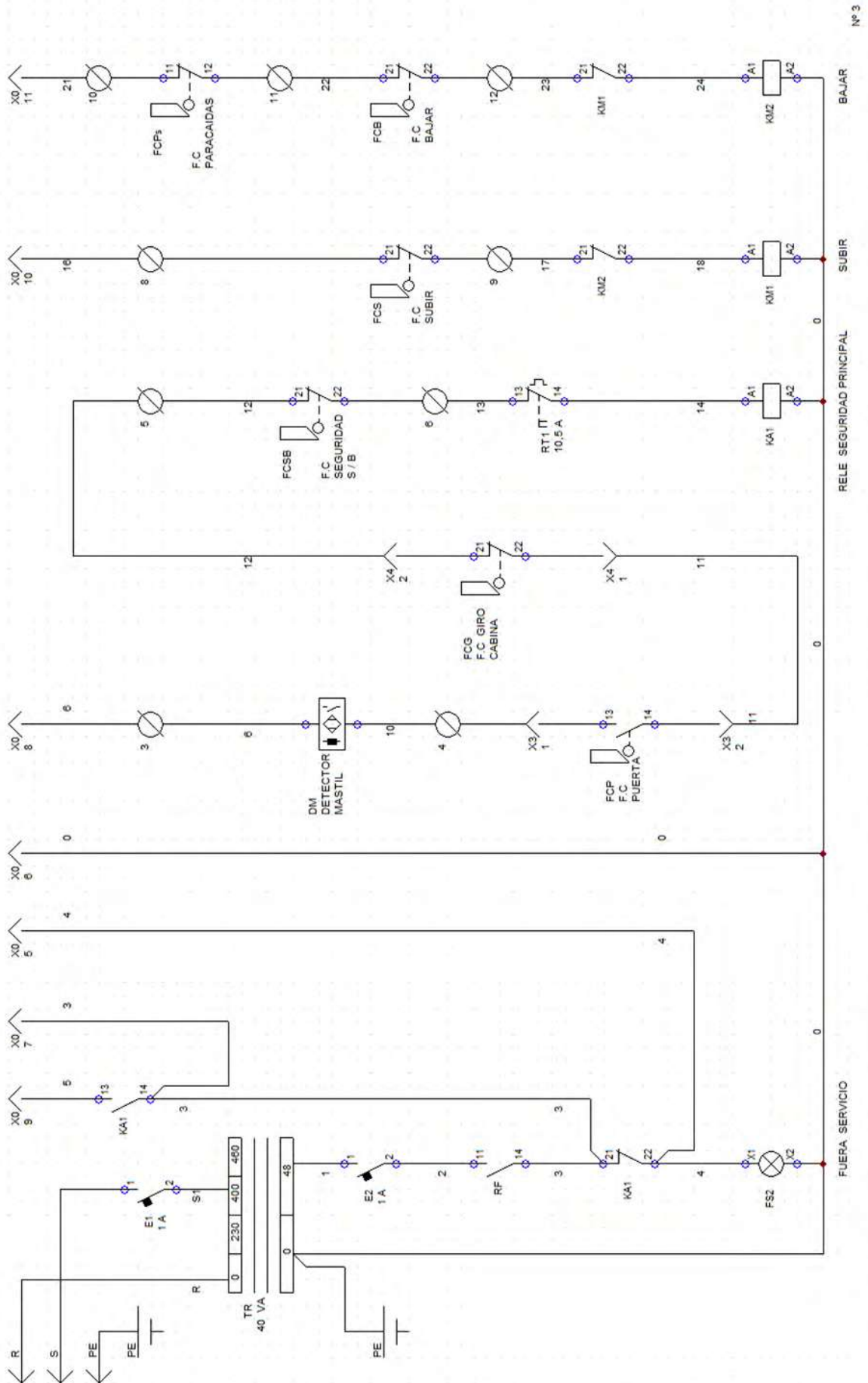

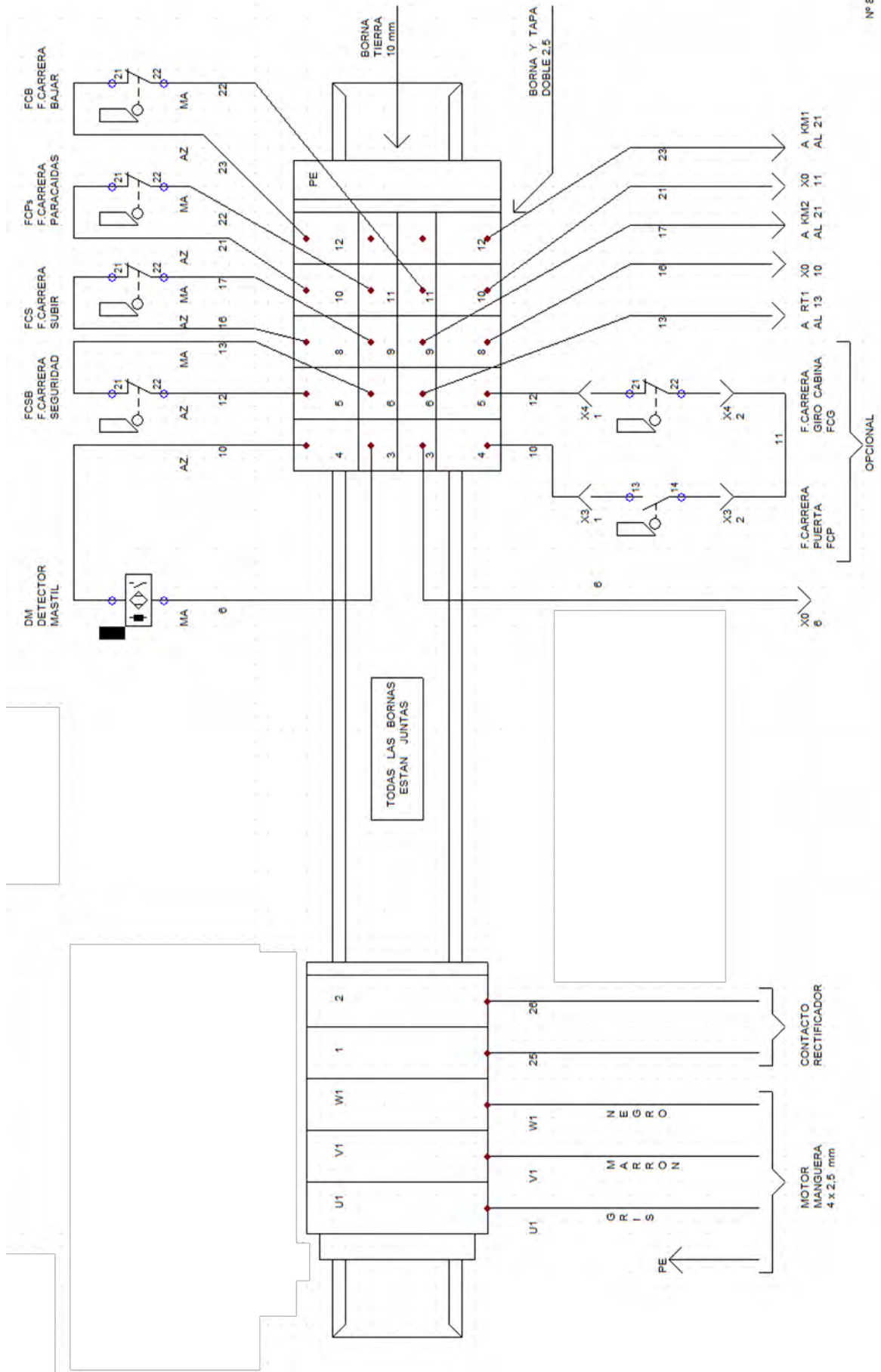

Nº 8

7. SPARE PARTS

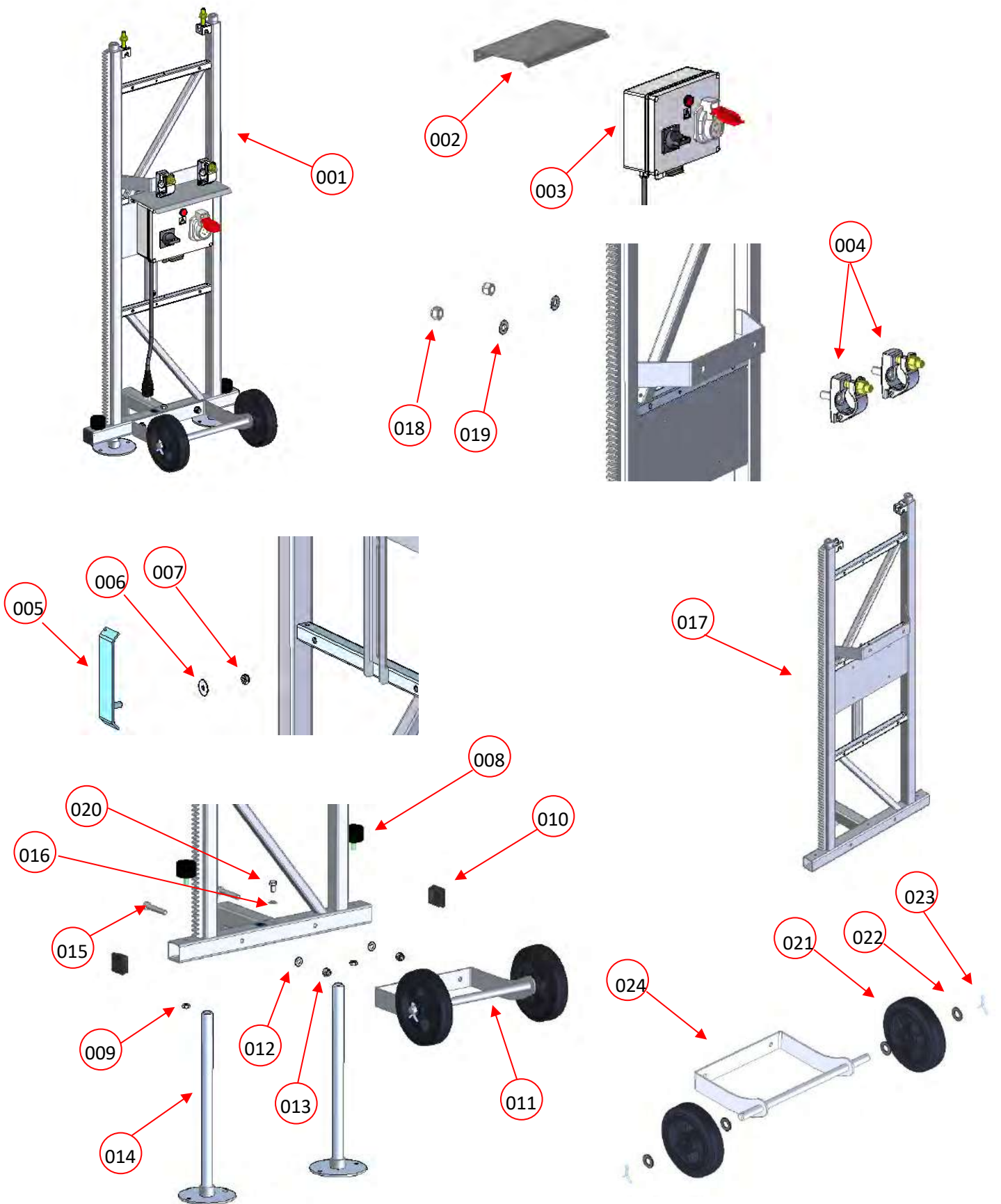

NUMBER	CODE	DESCRIPTION
001	158.0100R	BASE SET MC250 + FIRST MAST
002	158.0111	PROTECTOR OF CONTROL BOX
003	MANIOBRA051	CONTROL BOX
004	158.891	HALF CLAMP WITH WELDED SCREW
005	158.0191	STOP CAM
006	D9021-08,4	WASHER Ø8,4 DIN9021
007	D0985M08	LOCK NUT M8 DIN985
008	DTOPE06	SHOCK ABSORBER Ø50X35
009	D0934M10	NUT M10 DIN934
010	DTAP265050	SQUARE CAP 50
011	158.0150R	WHEEL SET
012	D0125-13	WASHER Ø13 DIN125
013	D0985M12	LOCK NUT M12 DIN985
014	158.0110	HEIGHT ADJUSTMENT SPINDLE
015	D093112075	SCREW M12X75 DIN931
016	D0125-10,5	WASHER Ø10,5 DIN125
017	158.1500	FIRST MAST
018	D0985M14	LOCK NUT M14 DIN985
019	D0125-15	WASHER Ø15 DIN125
020	D093310020	SCREW M10X20 DIN933
021	DRUEDA03	WHEEL
022	D0125-21	WASHER Ø21 DIN125
023	D009404040	PIN 4X40 DIN94
024	158.0151	WHEELS SUPPORT STRUCTURE

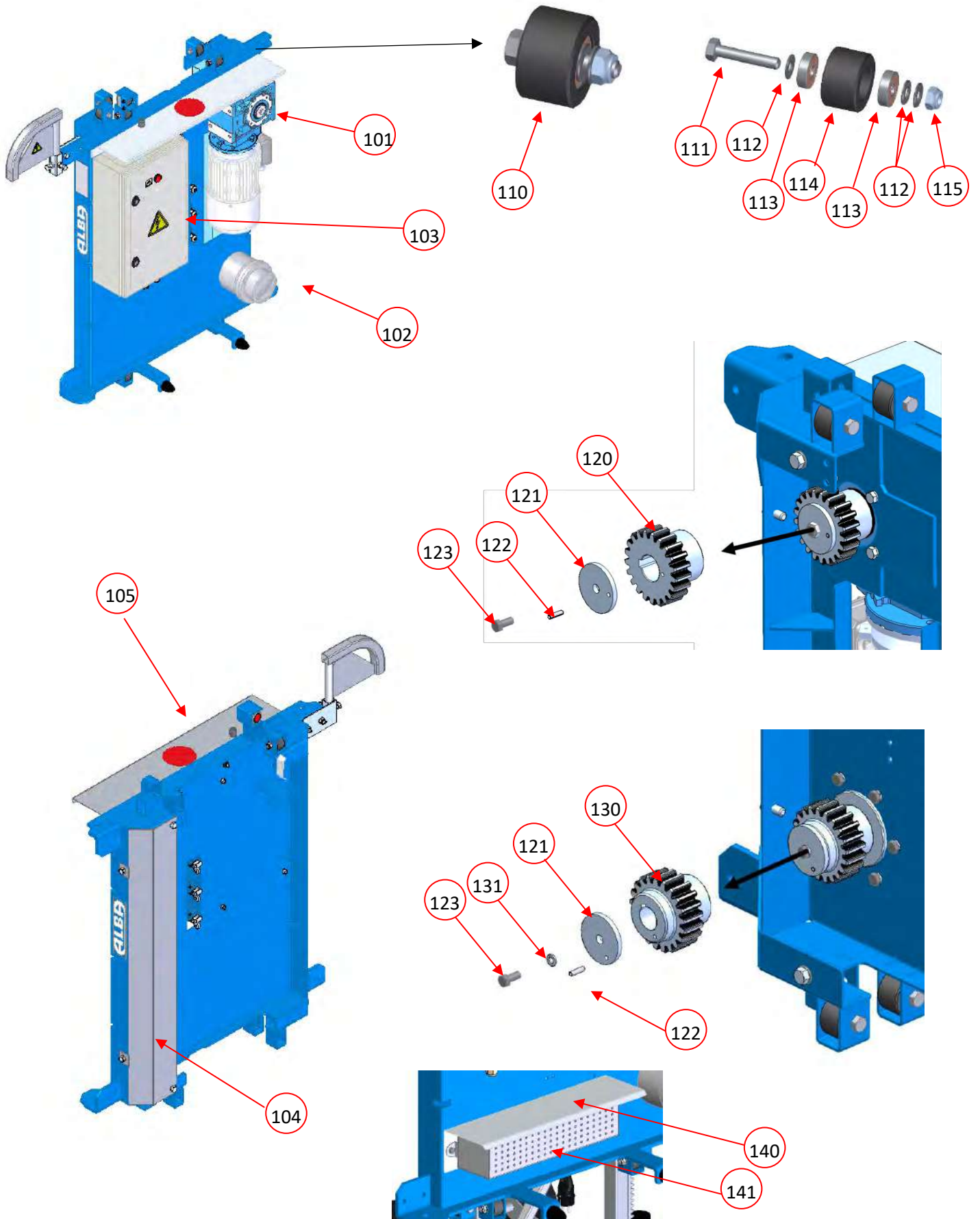

NUMBER	CODE	DESCRIPTION
101	M0045	GEARMOTOR1 PHASE 230 50/60HZ
	M004501	MOTOR1 PHASE 1,5KW 50/60HZ
	M004502	GEARBOX I=20
	M0044	GEARMOTOR3 PHASE 230/400V 50/60HZ
102	099.3003	PARACHUTE
103	MANIOBRA048	ELECTRIC BOX
	MANIOBRA047	ELECTRIC BOX WITH VARIATOR
	MANIOBRA058	ELECTRIC BOX THREEPHASE
104	158.3015	PINION PROTECTOR
105	158.3013	CHASSIS EQUIPMENT PROTECTOR
110	158.316R	GUIDE ROLLER ASSEMBLY
111	D093110055	SCREW M10X55 DIN931
112	D0125-10,5	WASHER Ø10,5 DIN125
113	R6200-2RS	BEARING 6200-2RS
114	158.3024	GUIDE ROLLER
115	D0985M10	LOCK NUT M10 DIN985
120	158.3005	PINION Z=21
121	158.3004	PINION LOCK WASHER
122	D734605020	PIN 5X20 DIN 7346
123	D093308020	SCREW M8X20 DIN933
130	158.3006	PINION
131	D0127-08	ELASTIC WASHER Ø8 DIN127
140	158.3018	RESISTANCE PROTECTOR
141	ERESIST01	RESISTANCE

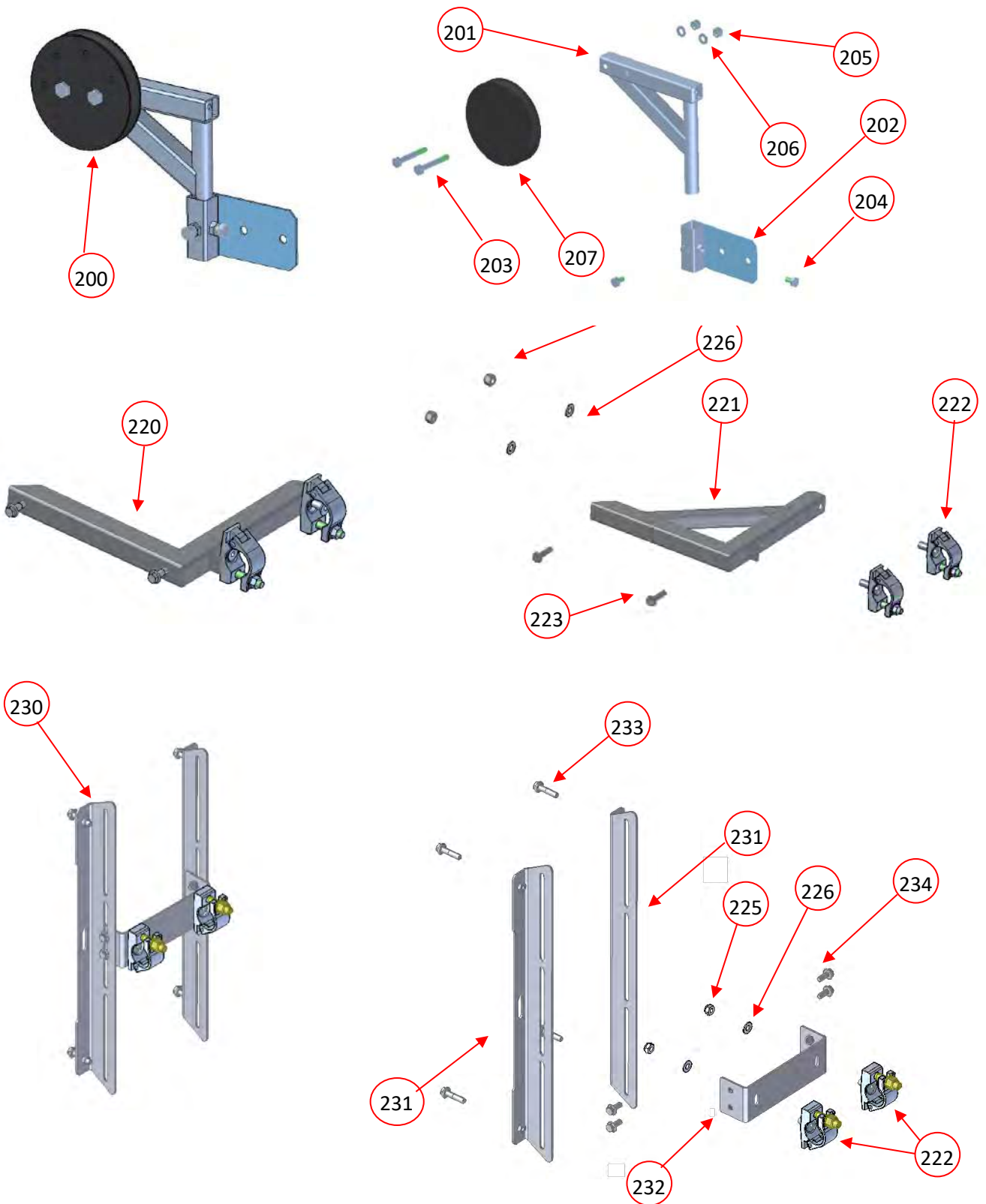

NUMBER	CODE	DESCRIPTION
200	158.64R	DRUM CABLE OUTLET
201	158.641	CABLE OUTLET GUIDE
202	158.642	CABLE OUTLET BRACKET
203	D093310030	SCREW M10X30 DIN933
204	D093310020	SCREW M10X20 DIN933
205	D0985M10	LOCK NUT M10 DIN985
206	D0125-10.5	WASHER Ø10,5 DIN125
207	158.6415	CABLE OUTPUT PULLEY
220	158.81	L TYPE ANCHORAGE
221	158.811	ANCHOR BRACKET
222	158.891	HALF CLAMP WITH WELDED SCREW
223	D692110045	SCREW M10X45 DIN6941
225	D0985M14	LOCK NUT M14 DIN985
226	D0125-15	WASHER Ø15 DIN125
230	158.84	H TYPE ANCHORAGE
231	152.8402	MAST COUPLING ANGLE
232	158.8400	MOUNTED FIXING PLATE
233	D962110045	SCREW M10X45 DIN6921
234	D692110025	SCREW M10X25 DIN6921

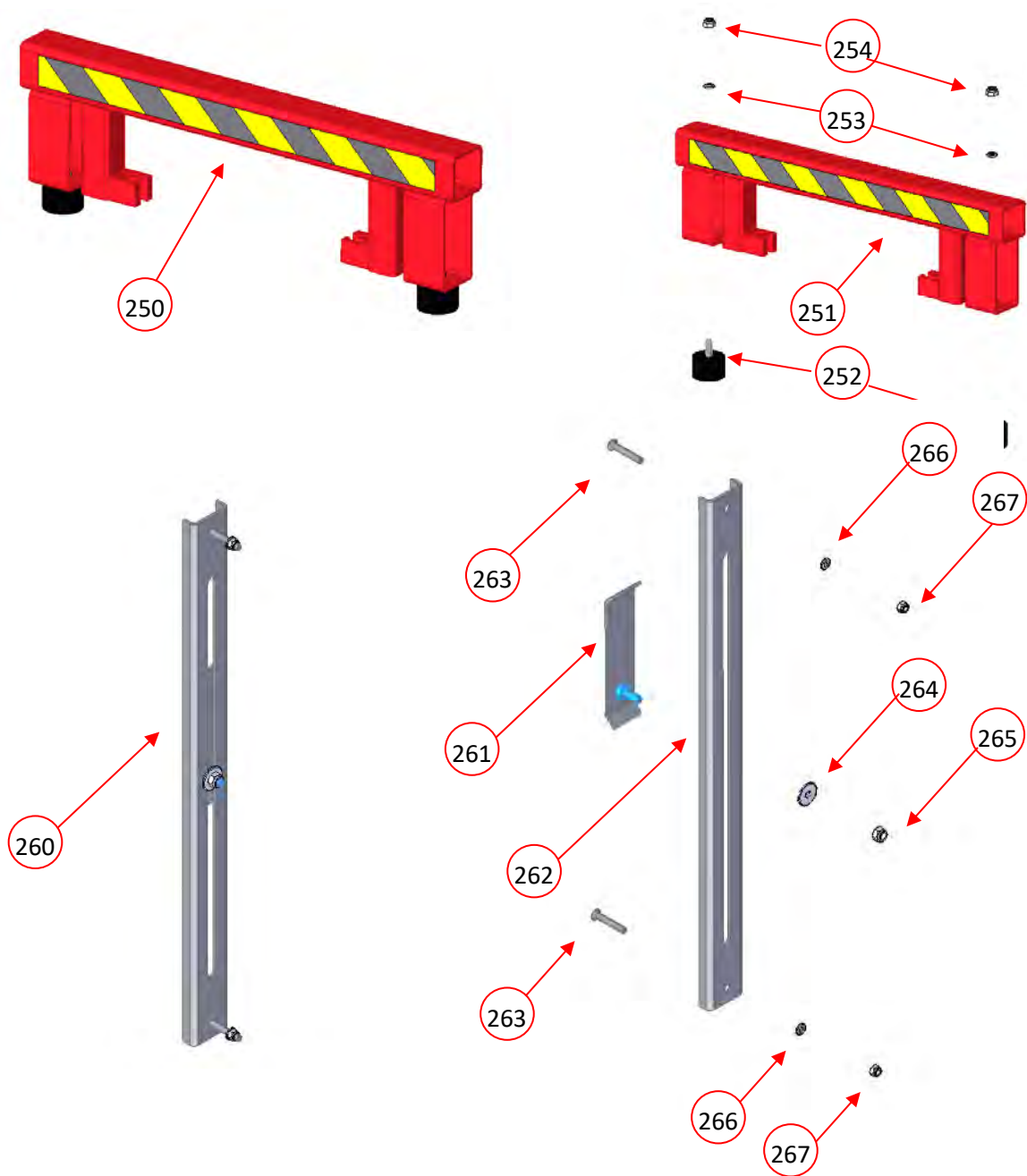

NUMBER	CODE	DESCRIPTION
250	158.014R	UPPER MAST STOP ASSEMBLY
251	158.0140	UPPER MAST STOP
252	DTOPE06	SHOCK ABSORBER Ø50X35
253	D0127-10	ELASTIC WASHER Ø10 DIN127
254	D0985M10	LOCK NUT M10 DIN985
260	158.019R	STOP CAM ASSEMBLY
261	158.0191	STOP CAM
262	158.0192	STOP CAM SLIDER
263	D799106040	SCREW M6X40 DIN7991
264	D0125-06,4	WASHER Ø6,4 DIN 125
265	D0985M06	LOCK NUT M6 DIN985
266	D9021-08,4	WASHER Ø8,4 DIN9021
267	D0985M08	LOCK NUT M8 DIN985

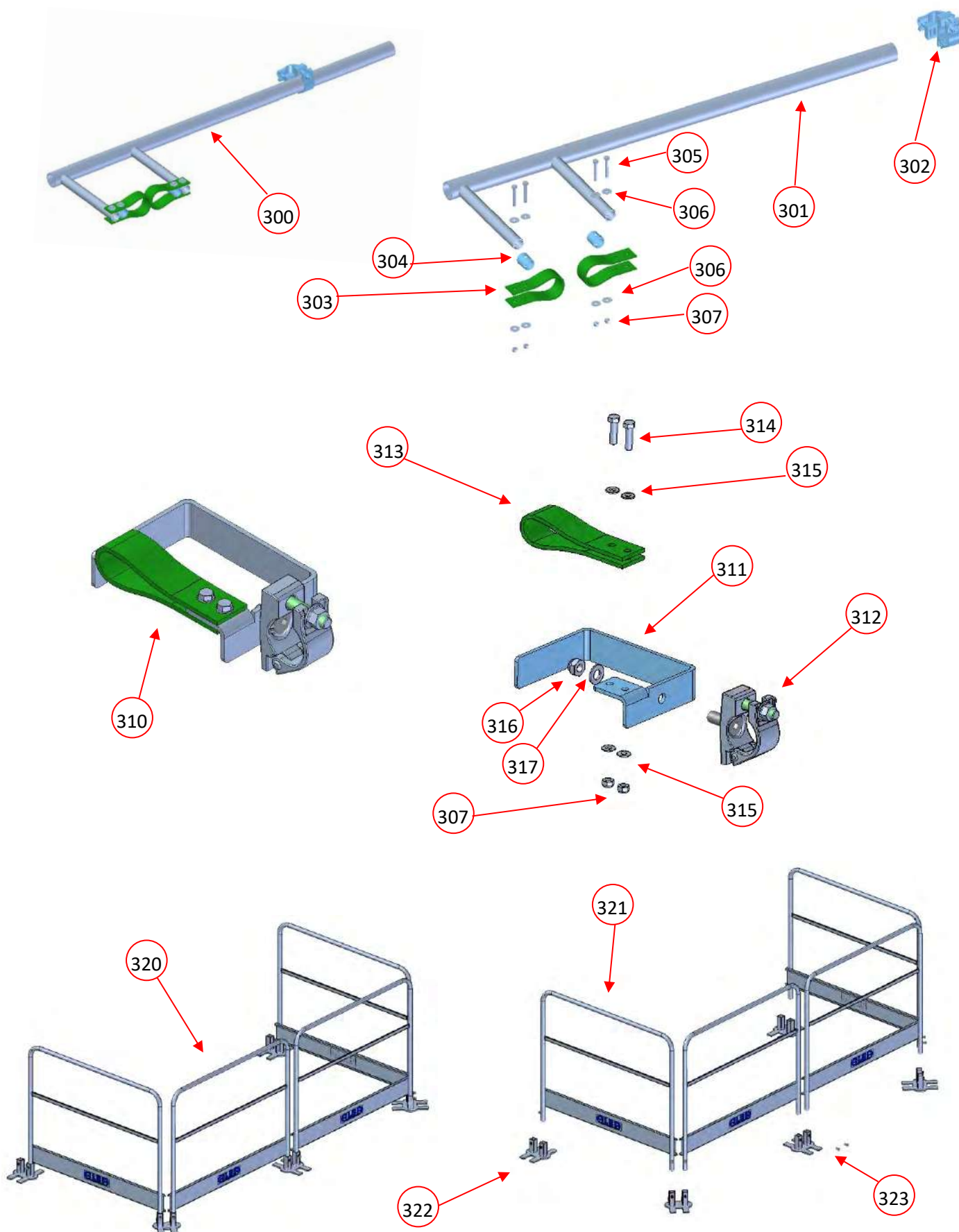

NUMBER	CODE	DESCRIPTION
300	158.671	CABLE GUIDE TYPE 1
301	153.6323	CABLE GUIDE SUPPORT
302	086.26	FIXED CLAMP ANCHOR Ø48
303	153.6325	SHORT RETENTION TIRE
304	153.6304	RETENTION TUBE
305	D093108055	SCREW M8X55 DIN933
306	D9021-08,4	WASHER Ø8,4 DIN9021
307	D0985M08	LOCK NUT M8 DIN985
310	158.672	CABLE GUIDE TYPE 2
311	158.6711	CABLE GUIDE PLATE
312	153.891	HALF CLAMP
313	158.6712	CABLE RETAINING PLATE
314	D093308030	SCREW M8X30 DIN933
315	D0125-08,4	WASHER Ø8,4 DIN125
316	D0985M12	LOCK NUT M12 DIN985
317	D0125-13	WASHER Ø13 DIN125
320	158.12	BASE PROTECTION KIT
321	086.42	DOOR L=1500MM
322	158.1210	DOOR SUPPORT
323	D093312025	SCREW M12X25 DIN933

7.1 900x500 cage

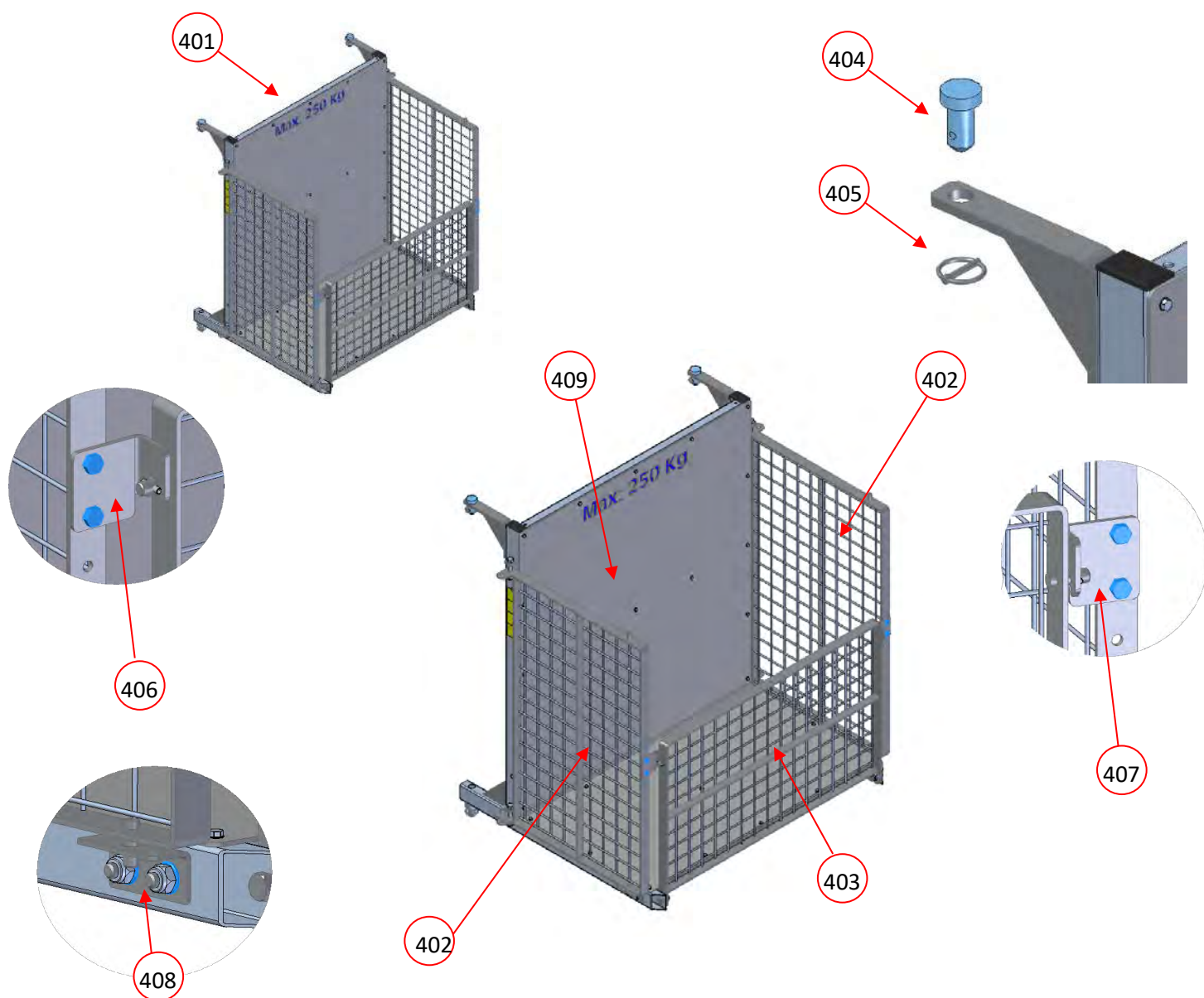

NUMBER	CODE	DESCRIPTION
401	158.41	900X500 CAGE
402	158.412	900X50 CAGE SIDE TRAP
403	158.413	900X50 CAGE FRONT HATCH
404	158.2009	PIN
405	D11023-04,5	WASHER PIN Ø4,5
406	158.4108I	LEFT LOCK TRIGGER
407	158.4108D	RIGHT LOCK TRIGGER
408	158.4105	CLOSING PLATE
409	158.411	CAGE BASE

7.2 Scaffold cage

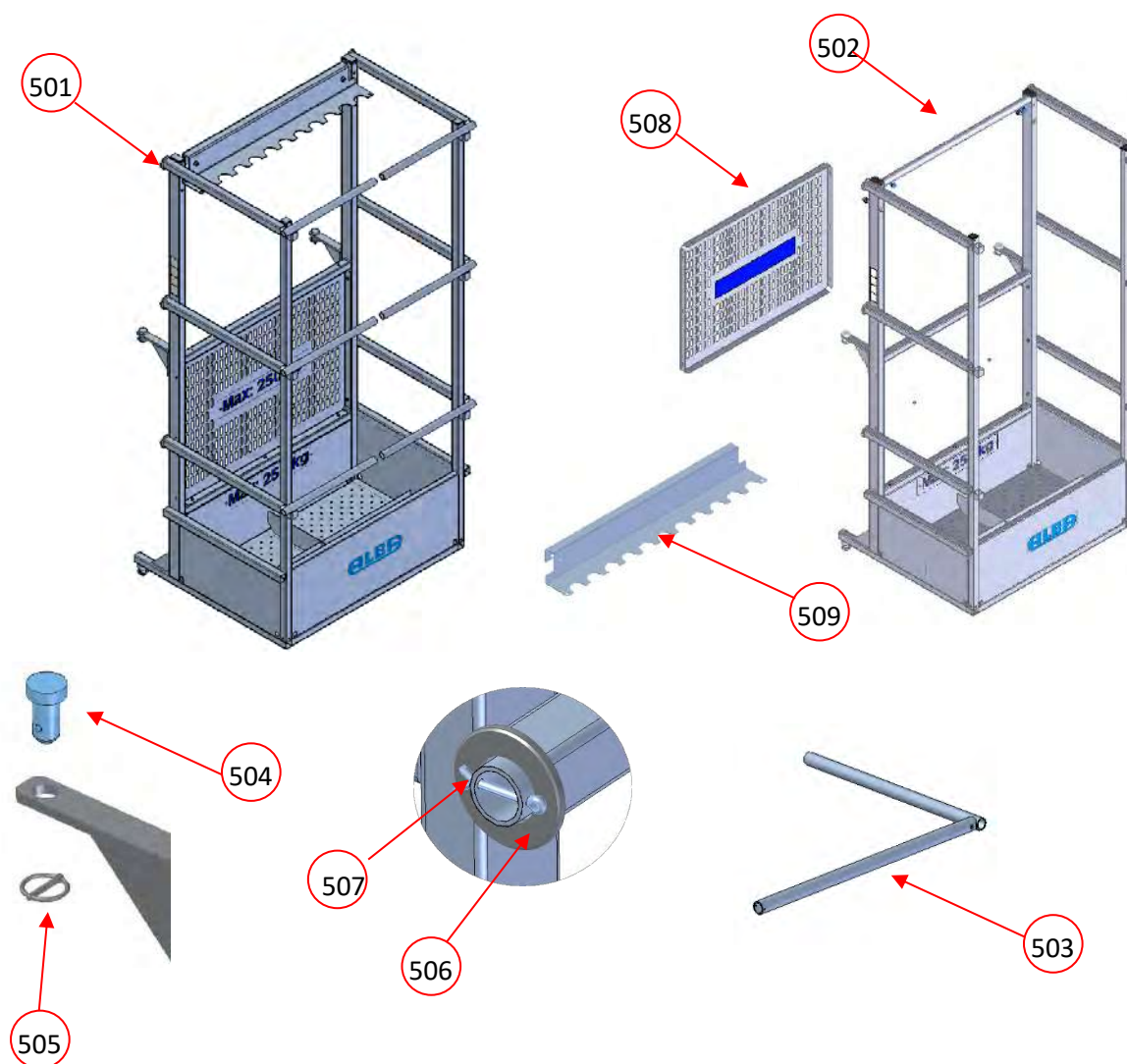

NUMBER	CODE	DESCRIPTION
501	158.42	SCAFFOLD CAGE
502	158.4210	SCAFFOLD CAGE BASE FRAME
503	158.4240	RETENTION ARM
504	158.2009	PIN
505	D11023-04,5	WASHER PIN $\varnothing 4,5$
506	D0125-28	WASHER DIN125 $\varnothing 28$
507	D009404032	PIN $\varnothing 4 \times 3,2$
508	158.4255	MAST SIDE PANEL
509	158.4226	TUBE ORGANIZER

7.3. 900x650 Cage

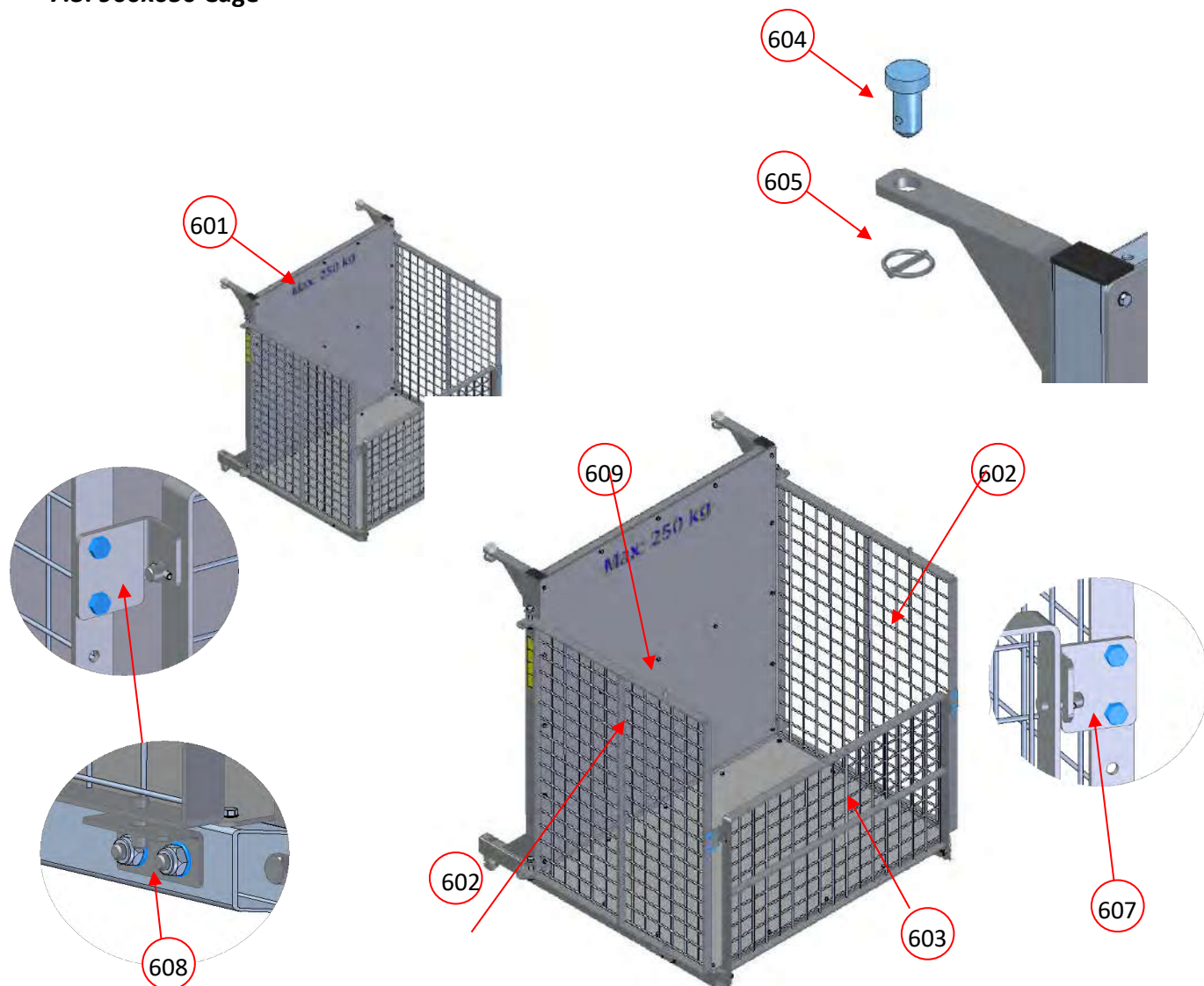

NUMBER	CODE	DESCRIPTION
601	158.46	900X650 CAGE
602	158.462	900X650CAGE SIDE TRAP
603	158.413	900X50 CAGE FRONT HATCH
604	158.2009	PIN
605	D11023-04,5	WASHER PIN Ø4,5
606	158.4108I	LEFT LOCK TRIGGER
607	158.4108D	RIGHT LOCK TRIGGER
608	158.4105	CLOSING PLATE
609	158.461	CAGE BASE

7.4.Electric spare parts

7.4.1 MC250 single phase

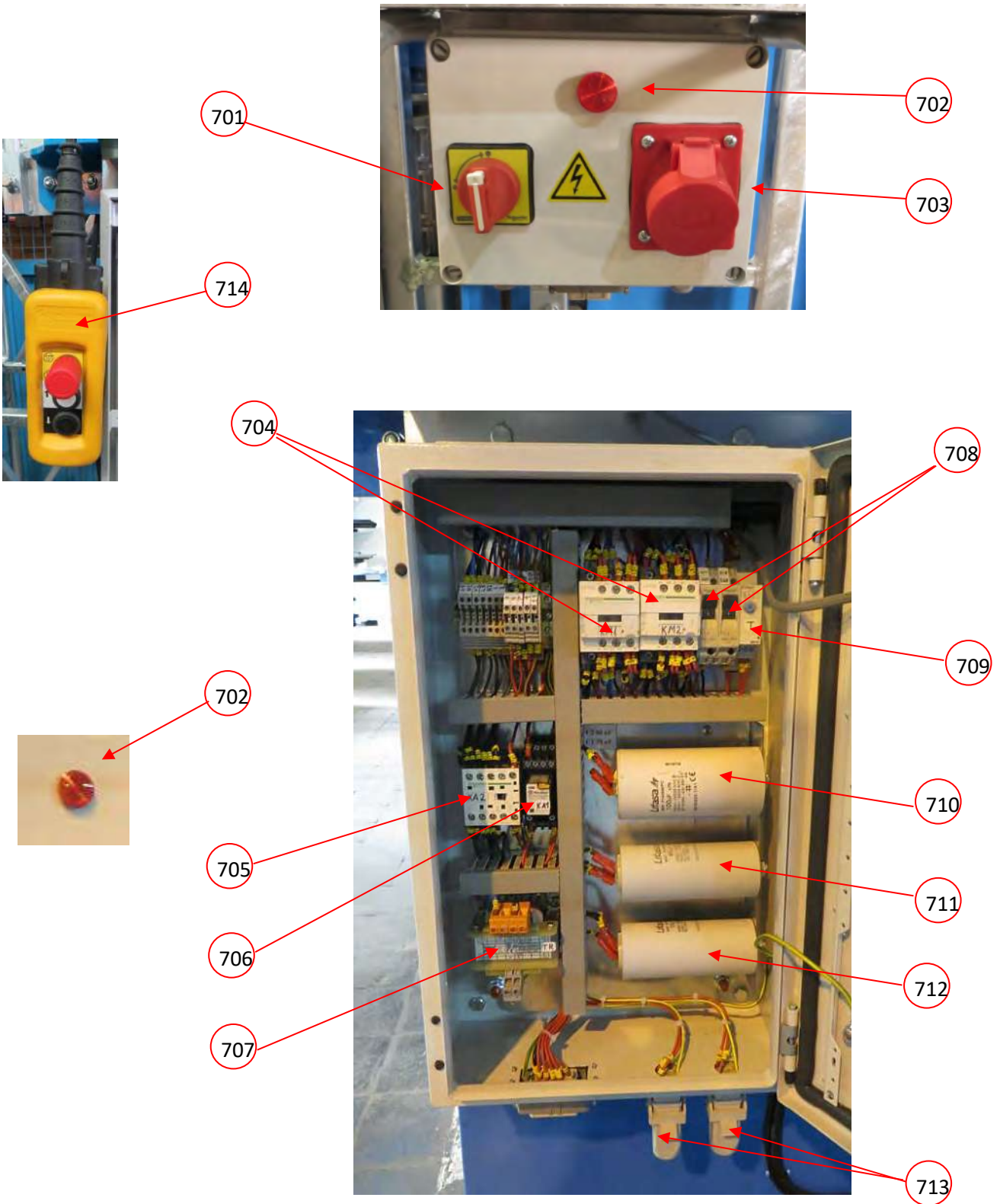

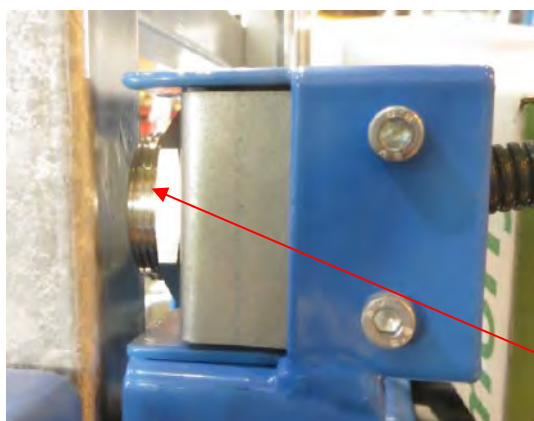

752



751

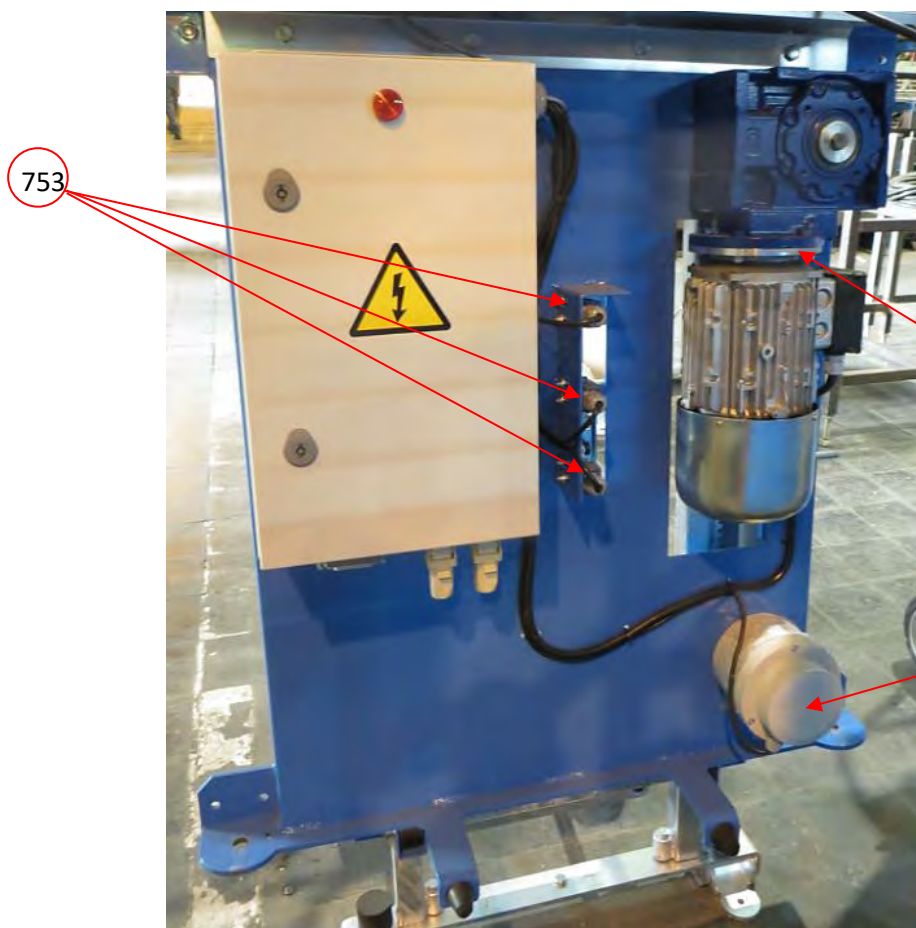

753

754

755

NUMBER	CODE	DESCRIPTION
701	EINTER09	SWITCH
702	EPILOTOR03	RED PILOT LIGHT
703	EBASE06	BASE EMPOTRABLE
704	ELC1D12E7	LC1D12E7 CONTACTOR
705	ELC1K1210E7	LC1K1210E7 MINI CONTACTOR
706	ERELE05	RELAY
707	ETR40VA48	TRANSFORMER 40VA
708	EGB2-CB06	THERMAL MAGNETIC CIRCUIT BREAKER GB2-CB06
709	EMAR1	TIMER MAR1 CROUZET
710	ECONDA100mF	CAPACITOR 100 μ F
711	ECONDA60mF	CAPACITOR 60 μ F
712	ECONDt70mF	CAPACITOR 70 μ F
713	ECAPOTA07	HARTING
714	EBOTONERA03	CONTROL MC250
751	EMICRO015	MAST PRESENCE DETECTOR
752	ERECT04	RECTIFIER
753	EMICRO013	LIMIT SWITCH
754	M0045	ONE PHASE GEARMOTOR 230V 50HZ FULL
	M004501	ONE PHASE MOTOR 230V 50HZ
	M004502	GEAR BOX I=20
755	099.3003	PARACHUTE

7.4.2 MC 250V single phase with inverter



819

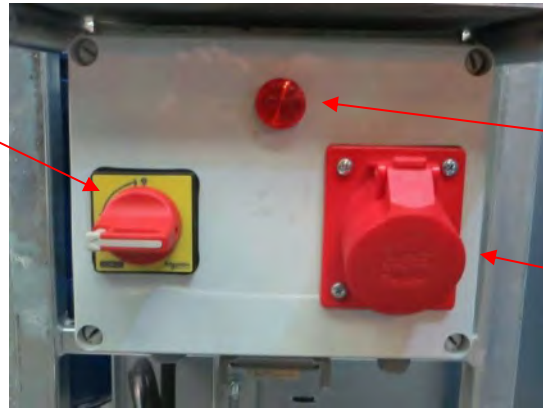

801

802

803



802

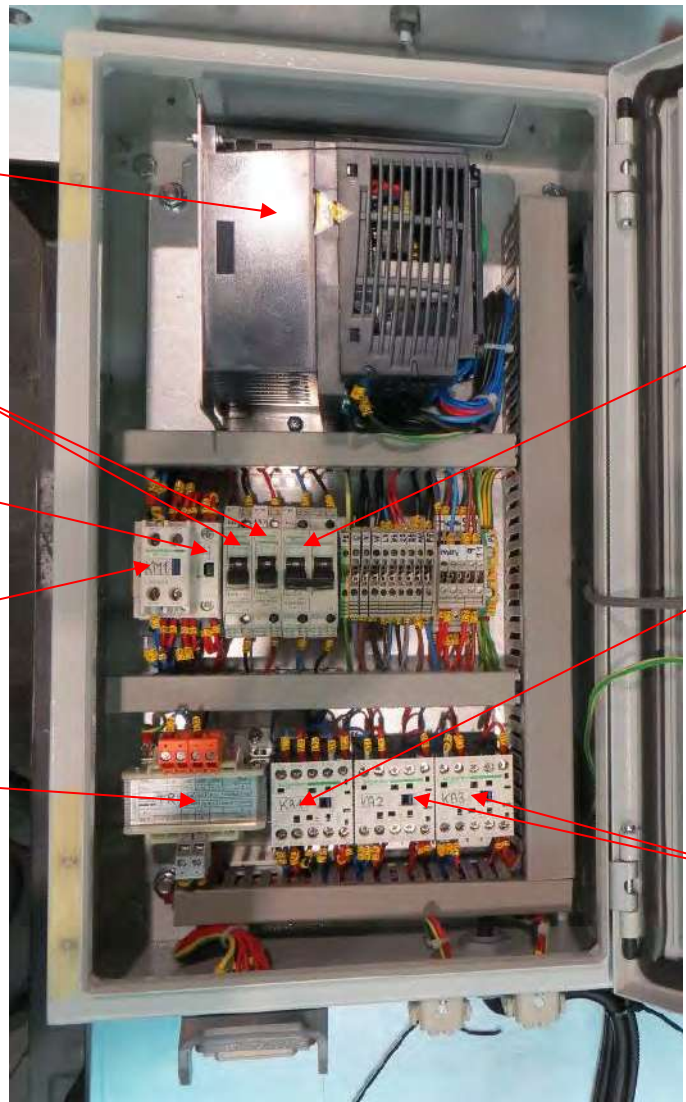

811

814

813

812

816

815

817

818

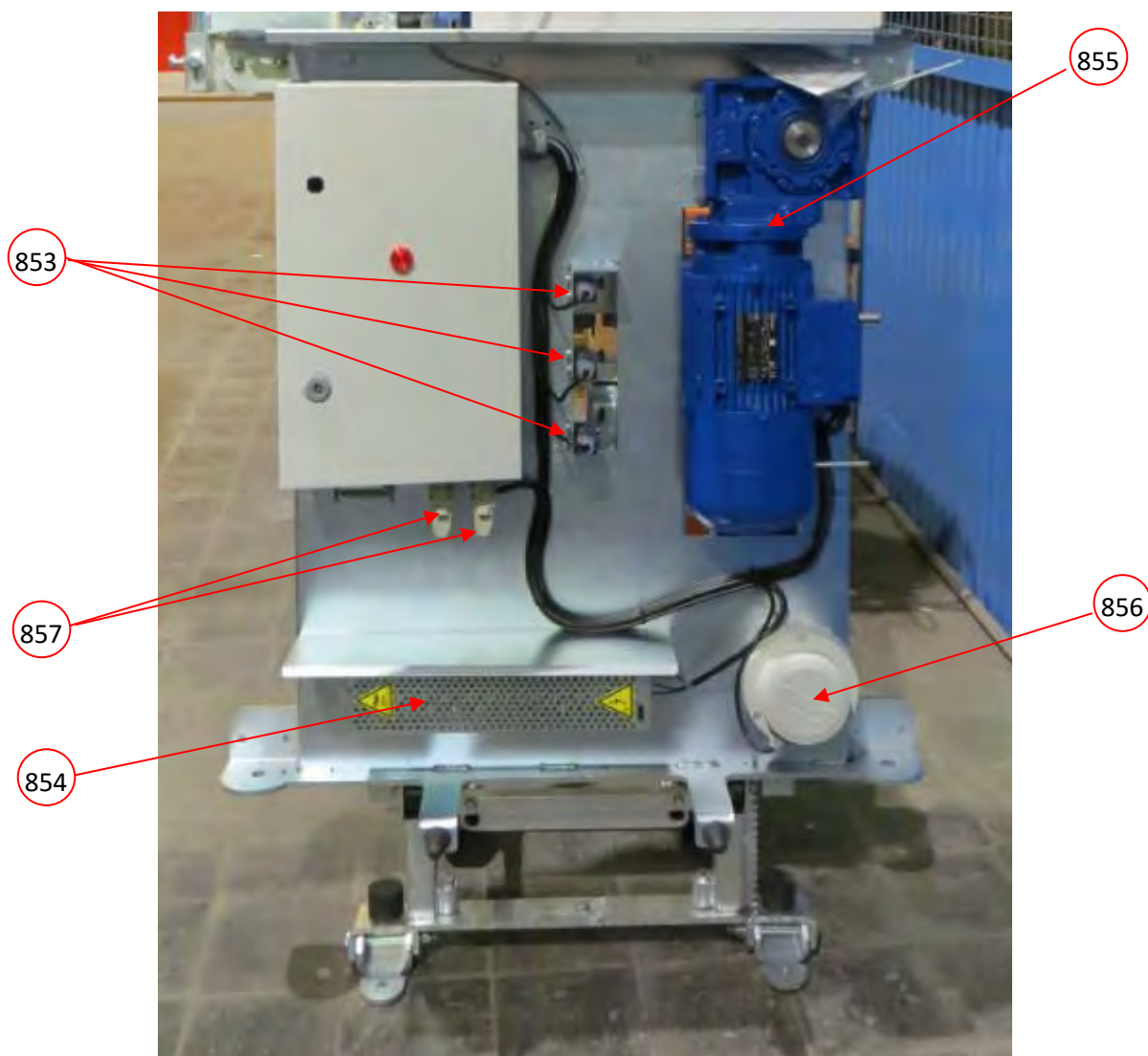
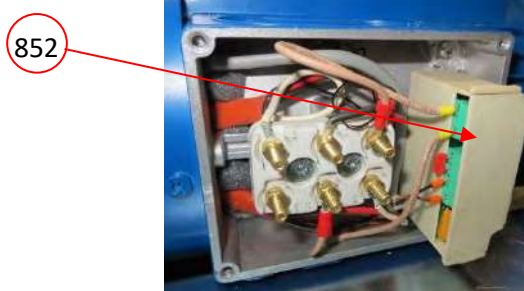
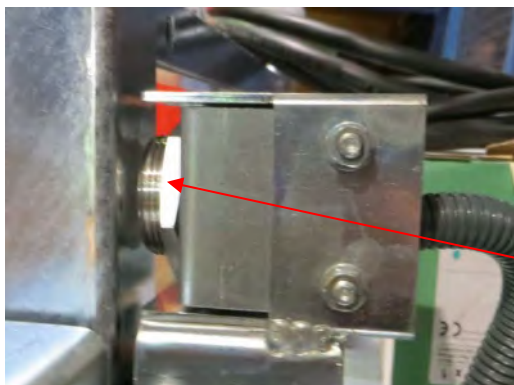

NUMBER	CODE	DESCRIPTION
801	EINTER09	SWITCH
802	EPILOTOR	RED PILOT LIGHT
803	EBASE06	HARTING
811	EVARIADOR03	VARIATOR 2,2KW
812	ELADN20	AUXILIARY LADN20
813	ELC1D18E7	CONTACTOR 18A
814	EGB2-CB06	THERMAL MAGNETIC CIRCUIT BREAKER
815	EGB2-DB05	THERMAL MAGNETIC CIRCUIT BREAKER
816	ETR40VA208	TRANSFORMER 40VA
817	ECA2KN40E7	AUXILIARY CONTACTOR
818	ECA2KN31E7	AUXILIARY CONTACTOR
819	EBOTONERA03	CONTROL MC250
851	EMICRO015	MAST PRESENCE DETECTOR
852	ERECT03	RECTIFIER
853	EMICRO013	LIMIT SWITCH
854	ERESIST001	RESISTANCE
855	M0044	GEAR MOTOR (COMPLETE)
	M004401	MOTOR 3 PHASE 1,5KW 400V 50/60HZ
	M004502	REDUCER I=20
856	099.3003	PARACHUTE
857	ECAPOTA07	HARTING

7.4.3 MC 250 three phase 400V 50Hz

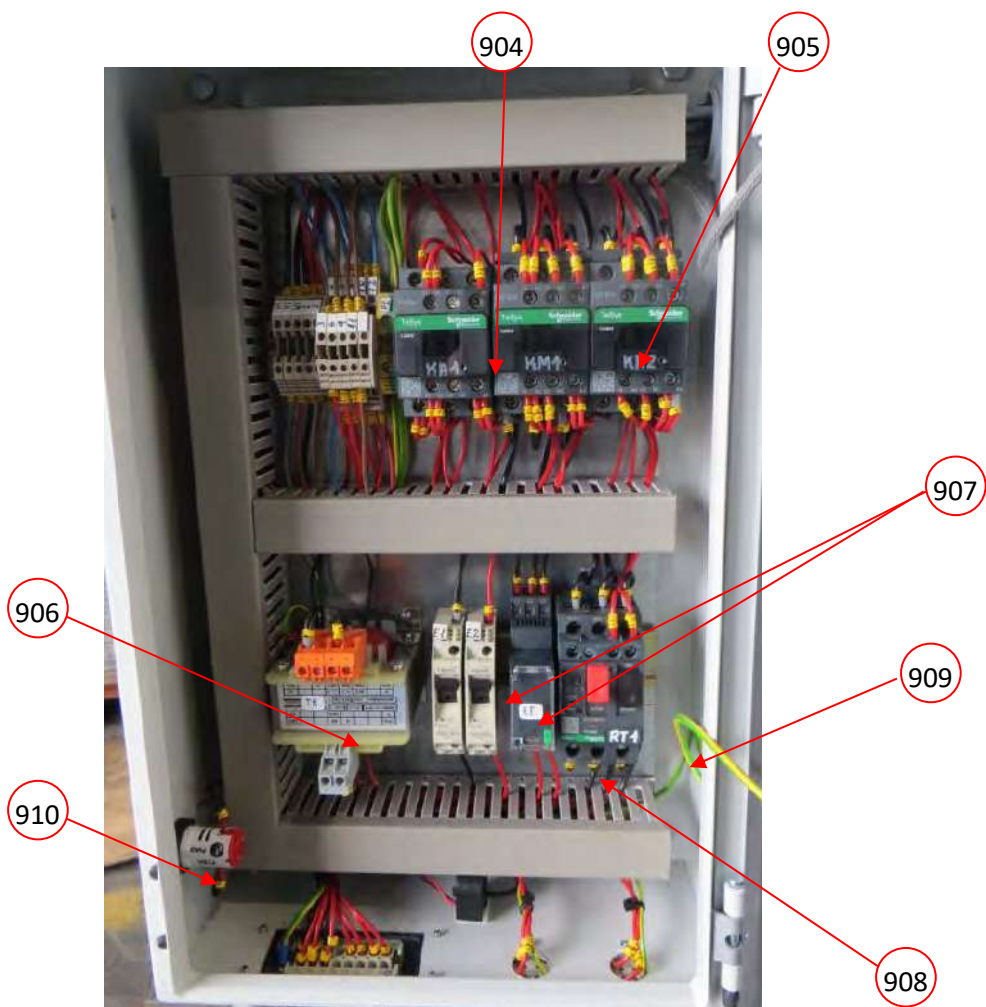
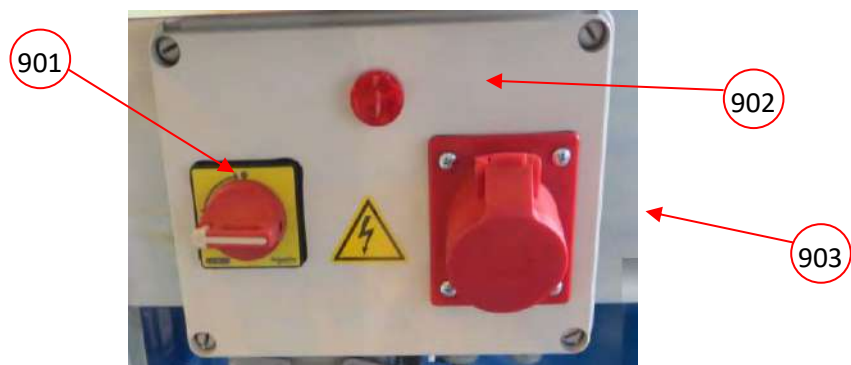

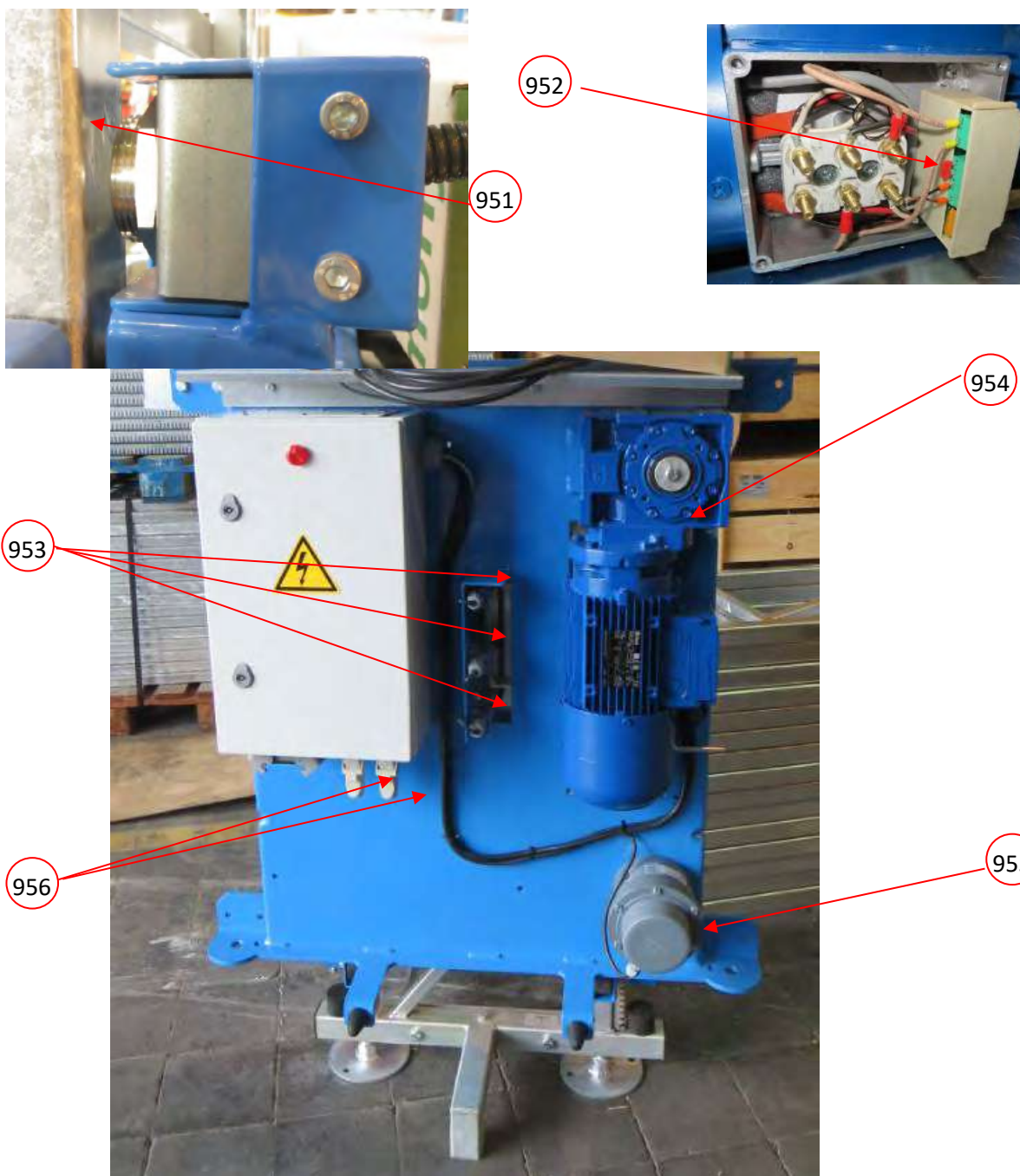

NUMBER	CODE	DESCRIPTION
901	EINTER09	SWITCH
902	EPILOTOR03	RED PILOT LIGHT
903	EBASE06	HARTING
904	ECAD32E7	AUXILIARY CONTACTOR
905	ELC2D12E7	REVERSE CONTACTOR 12A
906	ETR40VA	TRANSFORMER 40VA
907	EGB2-CB06	THERMAL MAGNETIC CIRCUIT BREAKER
908	ERM22TG20	PHASE RELAY
909	GV2ME10	THERMAL RELAY
951	EMICRO015	MAST PRESENCE DETECTOR
952	ERECT03	RECTIFIER
953	EMICRO013	LIMIT SWITCH
954	M0044	RESISTANCE
	M004401	GEAR MOTOR (COMPLETE)
	M004502	MOTOR 3 PHASE 1,5KW 400V 50/60HZ
955	099.3003	REDUCER I=20
956	ECAPOTA07	PARACHUTE

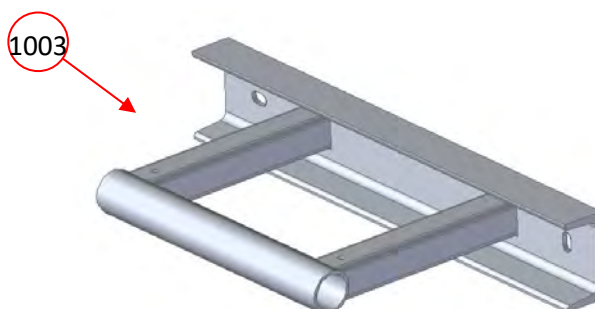
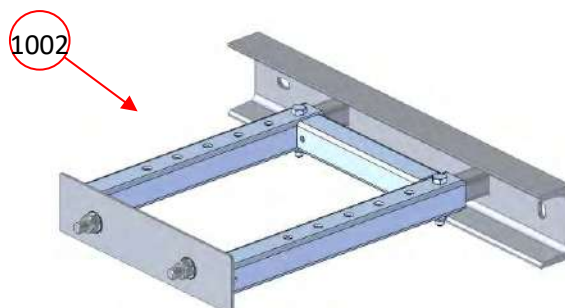
7.5 Wall anchorages

NUMBER	CODE	DESCRIPTION
1001	158.8610	SPECIAL ANCHOR FOR MOUNTING THE MAST COLUMN PERPEND. TO THE WALL
1002	158.8500	SPECIAL EXTENSIBLE ANCHORAGE FOR MOUNTING THE MAST COLUMN PARALLEL TO THE WALL
1003	158.8700	SPECIAL FIXED ANC. FOR MOUNTING THE MAST COLUMN PARALLEL TO THE WALL