



www.alba.es



Manufactured by CANOPY BRANDS EUROPE, S.L.U. (Spain)

Distributed by BEE ACCESS (USA)

2145 Indian Road, West Palm Beach, FL 33409

Ph.: 561.616.9003 / [www.beeaccess.com](http://www.beeaccess.com)

## MAST CLIMBING WORK PLATFORM

# PEC 120

### USER GUIDE

- INSTALLATION, USE & MAINTENANCE INSTRUCTIONS
- SPARE PARTS LIST

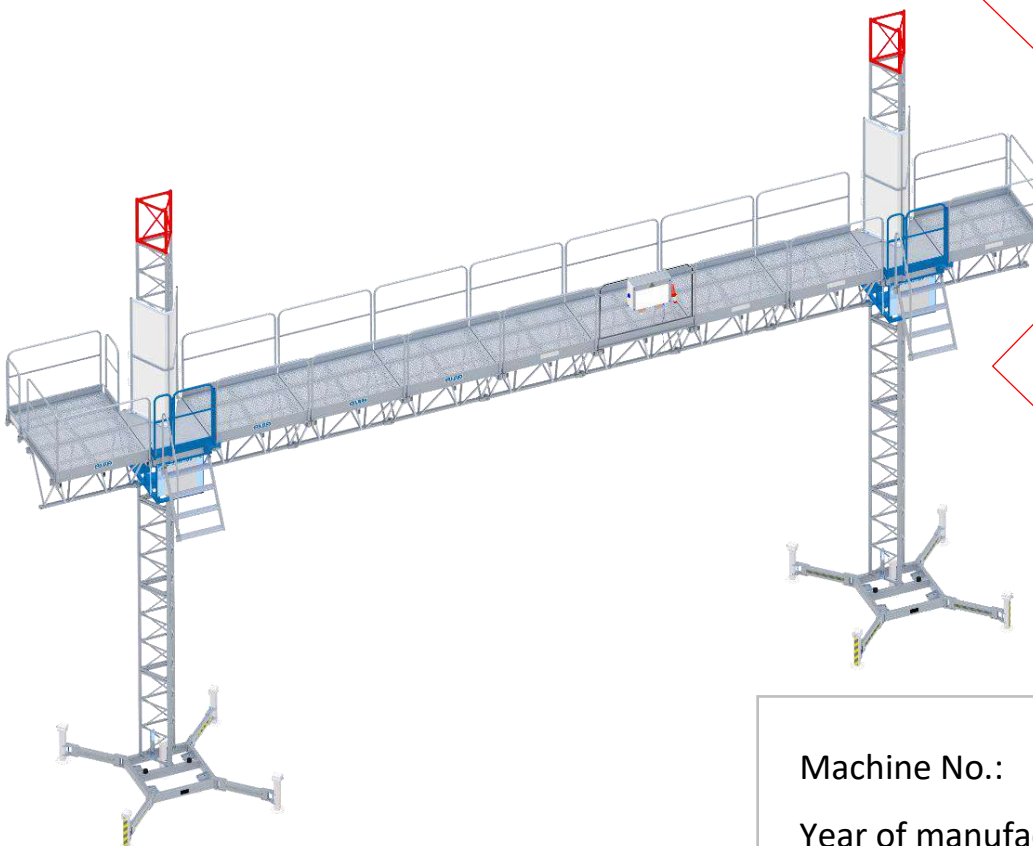

ENGLISH

COPY

Machine No.:

Year of manufacture:

Electric connection:

**KEEP THIS GUIDE FOR FUTURE REFERENCE**



**CONTENTS**

<b>1. DESCRIPTION OF THE MACHINE .....</b>	<b>3</b>
1.1 Introduction .....	
1.2 General information .....	4
1.3 Technical data .....	5
1.4 Main components.....	6
1.5 Main dimensions and weights .....	9
1.6 Safety devices of platform .....	14
<b>2. ASSEMBLY OF THE MACHINE.....</b>	<b>15</b>
2.1 Introduction.....	15
2.2 Transport and handle.....	15
2.3 Machine erection procedure .....	16
Step 1 Base to ground positioning.....	16
Step 2 Base leveling and resting on floor .....	19
Step 3 Assembly of platform .....	20
Step 4 Assembly of handrails, door and ladder .....	24
Step 5 Assembly of floor extensions and inner side perimeter protection .....	25
Step 6 Electrical equipment connection.....	29
Step 7 Adjusting leveling system .....	30
Step 8 Assembly of mast column.....	31
Step 9 Assembly of mast anchorage.....	34
Step 10 Assembly of end track cams and red mast .....	36
Step 11 Assembly of mast protector .....	37
Step 12 Filling MCWP handover certificate .....	37
2.4 Dismantling platform .....	38
<b>3. USING THE MACHINE .....</b>	<b>39</b>
3.1 Introduction .....	39
3.2 Use of control panel .....	40
3.3 Emergency stop .....	41
3.4 Emergency lowering .....	41
3.5 Checking platform operation before commissioning.....	43
3.6 Setting OUT OF SERVICE .....	44
3.7 Environmental conditions for safe use of machine .....	44
3.8 Intended applications .....	45
3.9 Applications and uses forbidden .....	45
<b>4. MAINTENANCE OF THE MACHINE .....</b>	<b>47</b>
4.1 DAILY Maintenance.....	47
4.2 PERIODICALLY Maintenance .....	58
4.3 Instructions for troubleshooting.....	69
4.4 Maintenance record .....	60
4.5 Breakdown record .....	62

**ANNEX I:** Load diagram.

**ANNEX II:** Handover certificate (Template)

**ANNEX III:** Mounting compatibility with PEC 120 prior to 2009

**TEST CERTIFICATE**

**ELECTRICAL SCHEME**

**LIST OF ELECTRICAL COMPONENTS**

**SPARE PARTS LIST**

The user's manual must be kept in good condition. This document contains 64 pages.  
Canopy brands Europe S.L.U. reserves the right of incorporating contents or modifications at any time with the purpose of improving both the machine and the information available on the same.



Copyright © Canopy brands Europe S.L.U.  
Rev. 06: Jan. 2025

## 1. DESCRIPTION OF THE MACHINE

### 1.1. Introduction.

Prior to erection and use, all users must read this manual. A thorough reading is recommended for full compliance with safety regulations.

This manual is delivered with the hoist, and its purpose is to give instructions for proper handling during transportation, erection and maintenance, in compliance with the provisions of ANSI/SAIA A92.9 for Mast Climbing Work Platforms. This instruction manual deals with proper use of the machine as well as proper erection and maintenance.

The manufacturer reserves the right to modify the machine for improvements, so that differences may be found in some manual details. In any case, the manufacturer commits to immediately adapting the manual to the improvements.

#### **Responsibility:**

CANOPY BRANDS EUROPE, S.L.U., declines any responsibility for damage caused by improper use of the machine as consequence of non-compliance with the provisions of the present Manual. Specifically declines any responsibility for damage derived from:

- Non-compliance with the provisions of this manual.
- Improper use of the machine.
- The use of non-original spare parts mentioned in the applicable section of this manual.
- Modifications introduced without express authorization from the manufacturer.
- Handling by not trained personnel for this purpose.

Only appointed personnel may use the machine and only qualified technical personnel acquainted with the machine may operate on any part of the same.

This manual must be available to the user at any time for any type of immediate consultation. In order to maintain it in perfect condition, keeping always a copy close to the machine is recommended.

In any case, the manual is aimed at strengthening knowledge and as a reminder for the personnel, who must previously be well trained by engineers or supervisors, who at the same time must be very experienced in this machine operation.

---

## 1.2. General information.

The rack and pinion mast climbing work platform is based on the principle of geared motor transmission to a rack and pinion mechanism. Components are modular and easy to install. It is simple to use and safe for facade work or rehabilitation, significantly reducing the erection time and man-hours.

This machine has been designed for temporary installation on site to work over facades and vertical structures, in single or double mast version depending on total work length. Its main advantage is the ability to access work point for materials and people in a fast and safe way. Below, please find the main points to bear in mind prior to erection and use of the machine.

- The platform is designed for transporting **people, along with their equipment and materials**.
- The machine runs vertically, geared to the mast rack and guided with support rollers.
- Machine operation must be carried out by **personnel appointed** by the person responsible for the machine on site. Operators must be trained in safe use of platforms.
- For erection, dismantling, maintenance and repair tasks, only **competent technical personnel** are allowed. These personnel must work under the overseeing and directing of a person qualified, and with practical experience. They must be trained in:
  - Understanding of assembly plan, dismantling or transformation of the platform.
  - Safety rules on assembly, dismantling or transformation of the platform.
  - Measures to prevent the falling of people or material.
  - Security measures in case of changing weather conditions could adversely affect the safety of the work platform.
  - The permissible load conditions, and other risks arising from those operations.
- The person responsible for installation will prepare an ASSEMBLY PLAN for the platform that will contain the manufacturer's general instructions contained in this manual. The assembly plan will be completed with **MCWP HANDOVER CERTIFICATE** (See example in Annex III), including specific features and capabilities of the particular installation. Any information on special assemblies not contained in the general instructions of manufacturer is to add as ANNEX into assembly plan.
- The machine is designed to be fixed to intervals adapted to a structure, i.e. concrete structure of construction building, a metallic structure, or similar. ALBA includes in the user's manual of the machine all the necessary information related to loads transmitted to the structure of vertical support and to the ground. It is the responsibility of the person responsible of contractor technical personnel to assure that, both the structure of support and the ground, support the loads indicated by the manufacturer.

### 1.3. Technical data.

#### TECHNICAL FEATURES:

	SINGLE MAST	TWIN MAST
Maximum length:	9,99 m [32-10]	32,11 m [105-4]
Maximum load:	1.800 Kg [4,000 lb]	4.100 Kg [ 9,050 lb]
Vertical speed (60 Hz):	9 m/min [30 ft/min]	
Platform width:	1.200 mm [47 in]	
Platform extension:	· Standard: 1.000 mm [40 in] · Max: 2.000 mm [80 in] (*)	
Motor power (60 Hz):	2 x 2,65 KW	4 x 2,65 KW
Maximum height:	120 m [ 390 ft]	
Anchorage each (max.):	6 m [ 20 ft]	
Height over last anchorage:	1,5 m [5 ft]	
First anchorage height (max.):	6 m [ 20 ft]	
Loading height-to-ground:	1.500 mm [5 ft]	
Reference normative:	ANSI/SAIA A92.9	
Mast	Triangle	
Length:	1,5 m [59,37 in]	
Weight:	48 Kg [ 106 lb]	

(\*) Case of longer floor extension, ask manufacturer.

#### ELECTRIC FEATURES:

	SINGLE MAST	TWIN MAST
	60 Hz	60 Hz
Motor power:	2 x 2,65 KW	4 x 2,65 KW
Input power connection:	460 V – 60Hz (*)	460 V – 60Hz (*)
Power consumption:	5,3 KW	10,6 KW
Nominal current (460V):	12 A	24 A
Supply power:	10 KVA	20 KVA
Starting current:	66 A	132 A
Overload protection (**)	4 x 32 A	
Differential protection (**)		
Caliber:	32 A	
Sensitivity:	300 mA	
Control voltage:	48 V	
Aux. hand tools socket:	120 V – 60Hz - 13 A	
Cable section:	4 x 4 mm <sup>2</sup> [AWG 11]	4 x 6 mm <sup>2</sup> [AWG 9]

(\*) Transformer 220-460V available for 220V-60Hz main supply. Ask the manufacturer.

(\*\*) Required on electric main supply point where machine is connected.

**1.4. Main components**

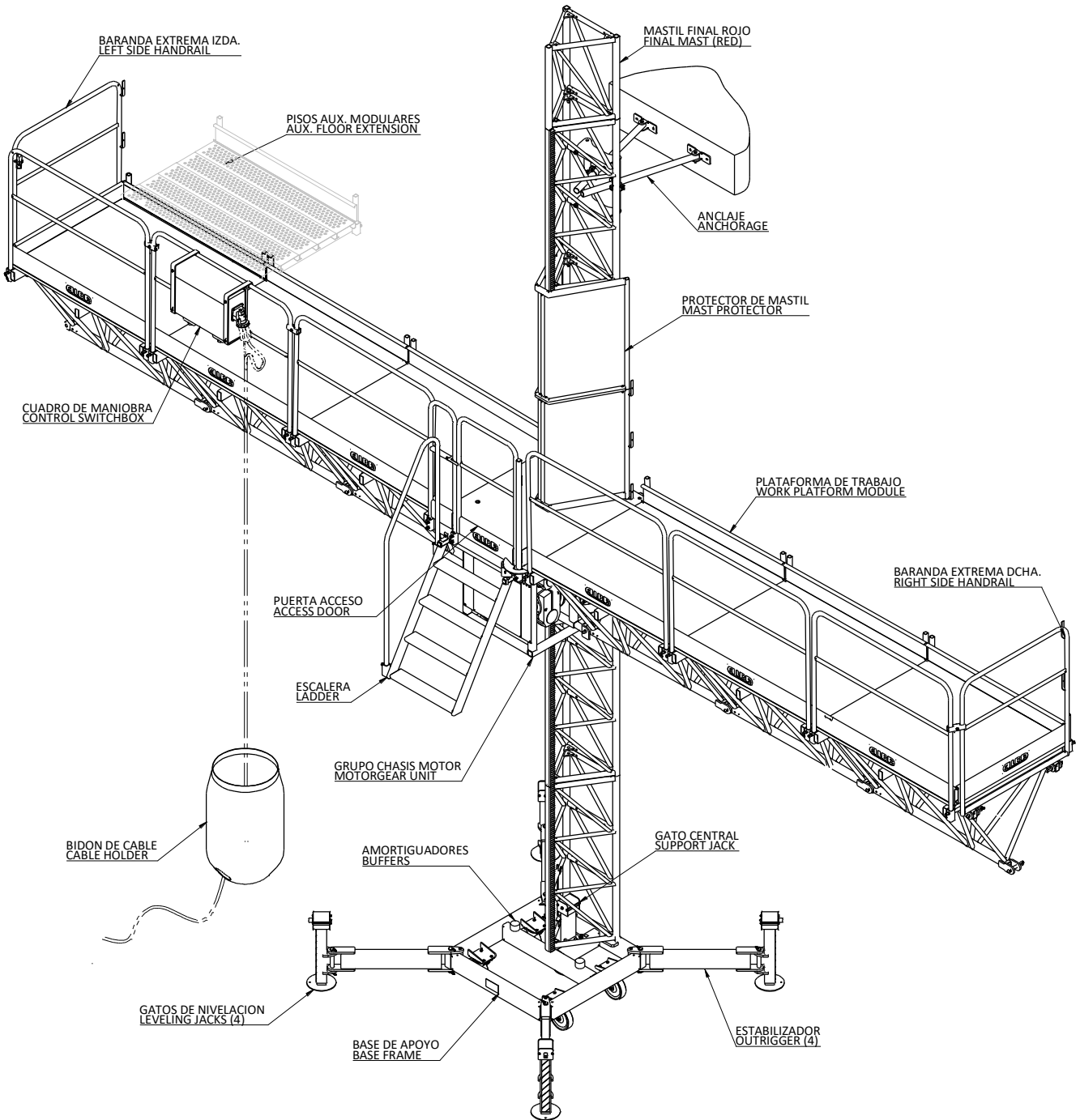

**SINGLE MAST PLATFORM**

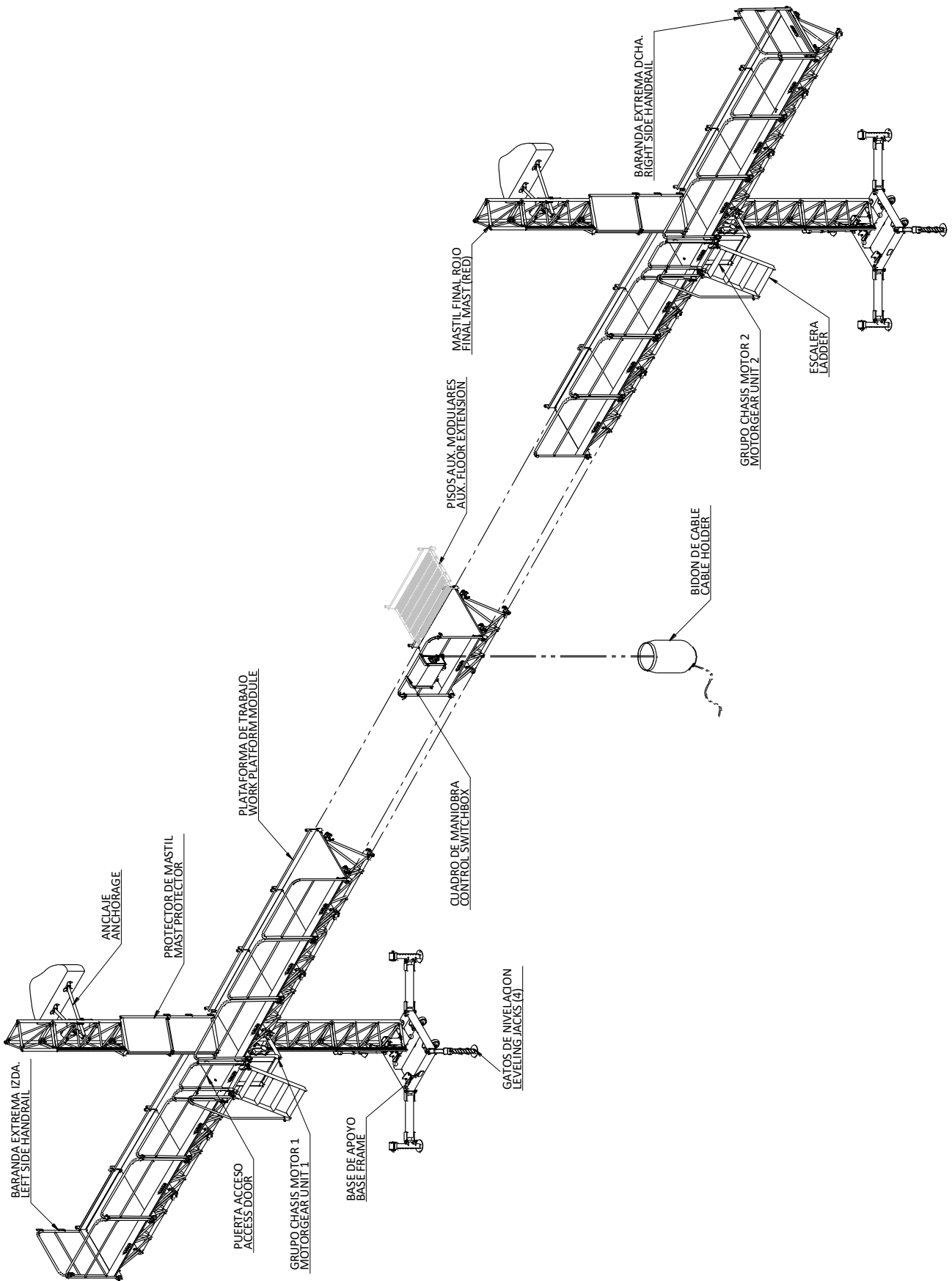

**TWIN MAST PLATFORM**

- **MAST BASE SUPPORT:**  
Main structure that is used as a support for the hoist and for the column of masts. It transmits the efforts generated to the ground. It has rotating stabilizers for levelling and support jacks. Base also incorporates buffers to avoid the platform hitting metallic structure.
- **MAST:**  
Modular structure for the vertical movement of the machine. It consists of a modular triangle structure of 1,5 m. It has one welded rack for the travel of platform across. Mast modules are designed for their union by means of screws and for the anchorage to a vertical structure of support to suitable intervals.
- **MOTOR GROUP:**  
Structure that incorporates gearmotor system and that provides the movement to the platform. It incorporates both the gearmotor and the safety systems to control the movements of the machine. It fits to the platform by means of bolts on the sides of the chassis.
- **PLATAFORM:**  
Modular horizontal working structure, with several length possibilities, that are fitted ones to each other by means of 3 safety bolts with pins and chains to avoid losing the pins. Platform modules are made by a tubular structure in a triangle truss, with a metallic floor at the top area serving as a working zone. It has handrail brackets and it's possible to assemble modular extensions of the main platform.
- **EXTREME SIDE HANDRAILS:**  
Lateral handrails on the platform sides to cover the whole perimeter of the platform. They have brackets to fit them to the platform with superior bolts, and also to extend protection to auxiliary extension floor if necessary.
- **ANCHORAGE:**  
That's the system of mast anchorage to an external support structure. There is several anchorage arm's length, depending on distance to façade when installing the platform.
- **CONTROL SWITCHBOARD:**  
It contains the main electrical components of the platform, and the control knobs, and it's connected to the electrical supply with a feed cable (not supplied with the platform). The cable is collected into the cable bin (supplied with the platform)
- **CABLE BIN:**  
It's used to wind the electrical supply wire when the platform moves, avoiding cable hitch. The cable bin receives wire winding inside.
- **FINAL MAST MODULE:**  
Mast module without rack that is installed in the top limit of the column of masts. It prevents the machine from exceeding the top limit of the mast, and its red color allows immediate identification.

**1.5. Main dimensions and weights**

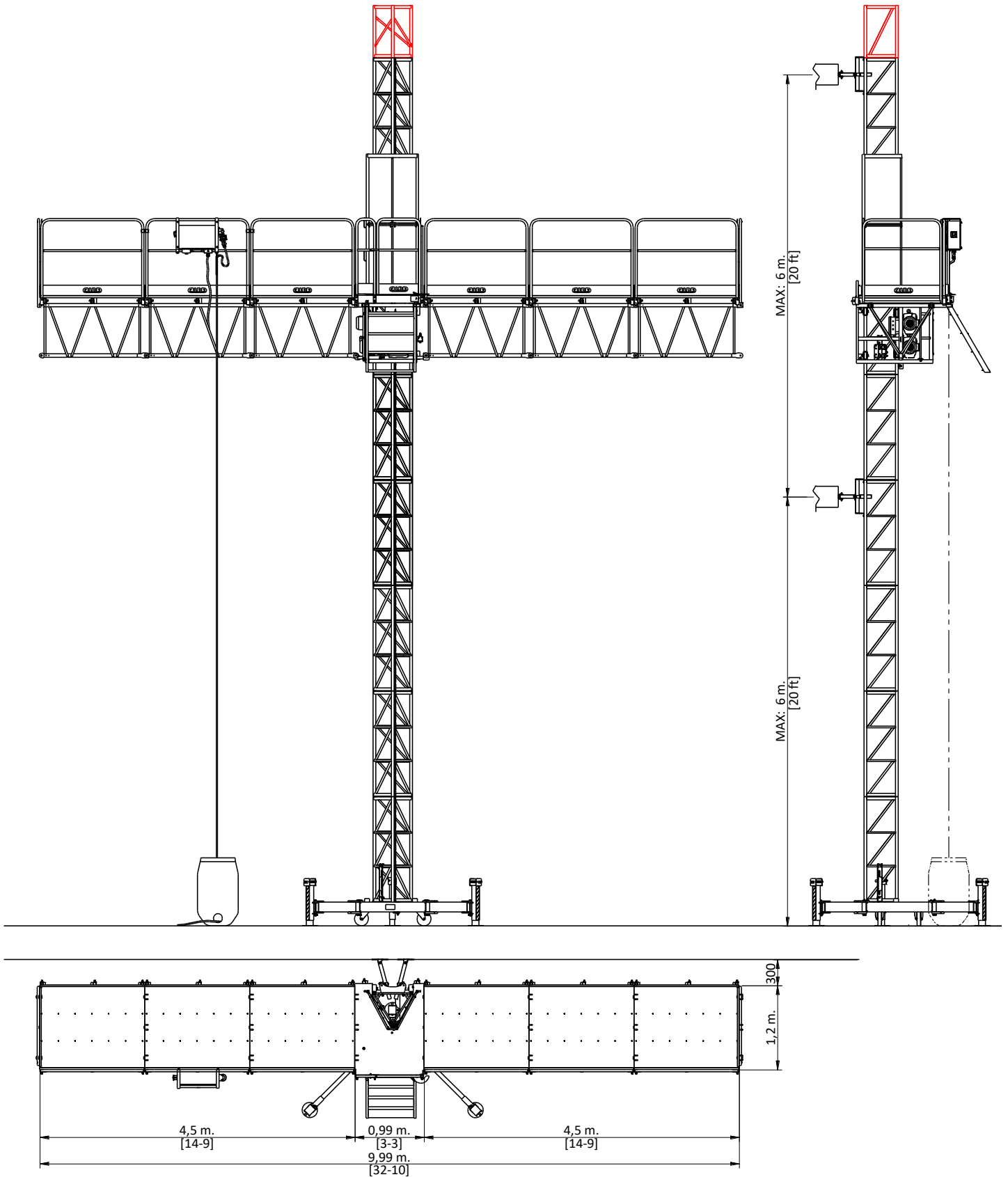

**SINGLE MAST PLATFORM**

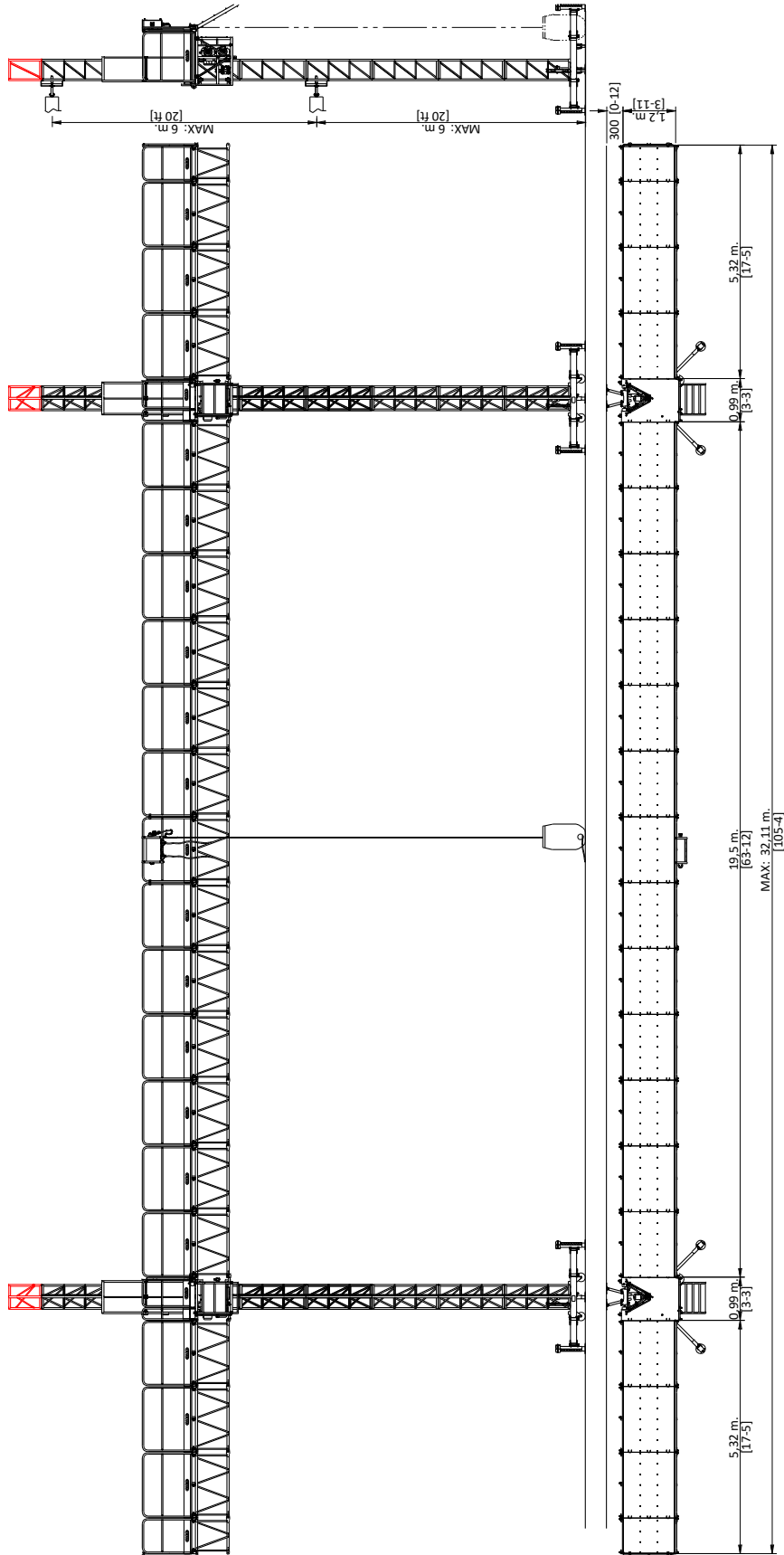

**TWIN MAST PLATFORM**

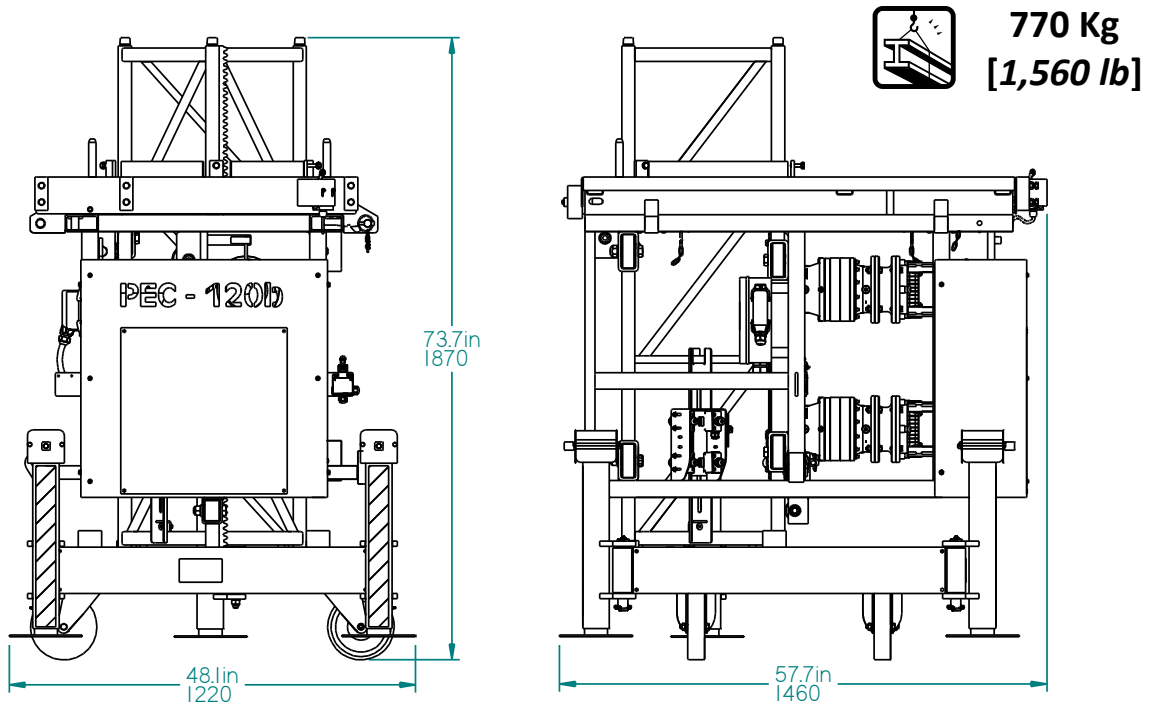

**BASIC MACHINE SET (SHIPPING)**

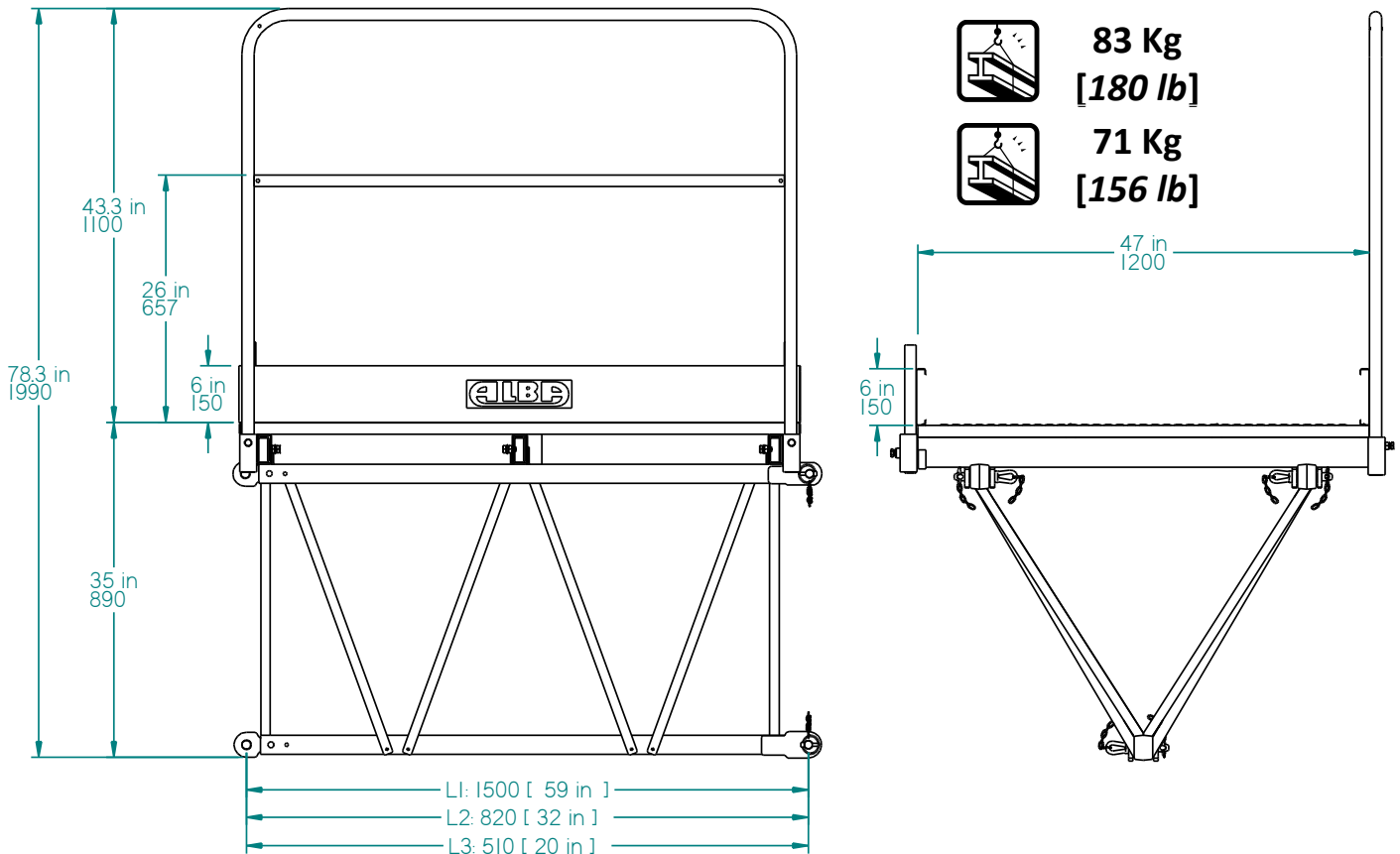
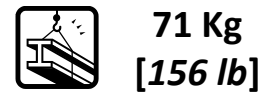
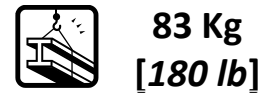
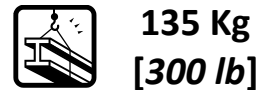

**PLATFORM SET**

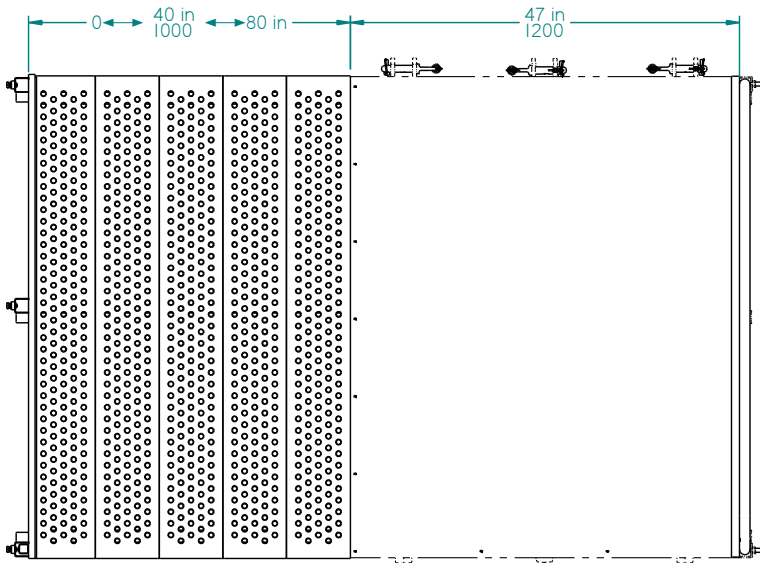

**PLATFORM EXTENSION**



**7 Kg**  
**[15.4 lb]**



**4 Kg**  
**[8.8 lb]**



**2,5 Kg**  
**[5.5 lb]**

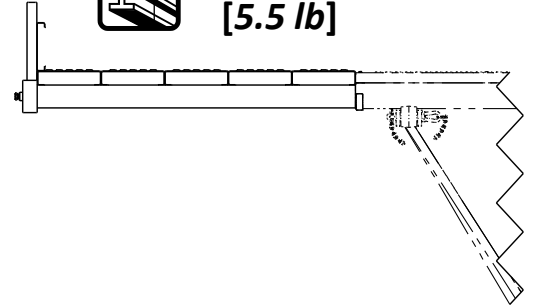

**20...25 Kg**  
**[44...55 lb]**



**30 Kg**  
**[66 lb]**



**36 Kg**  
**[80 lb]**

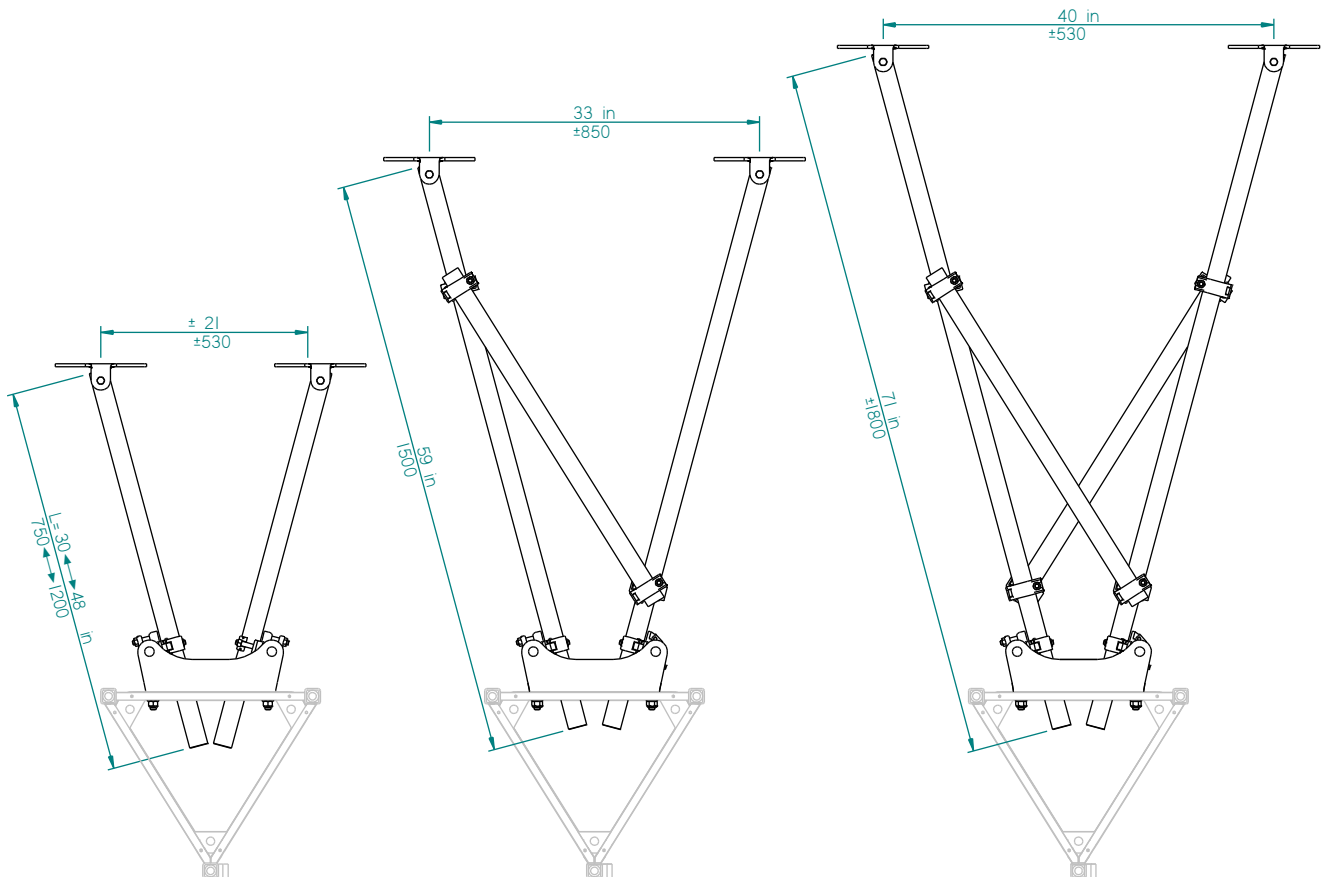

**ANCHORING SETS**

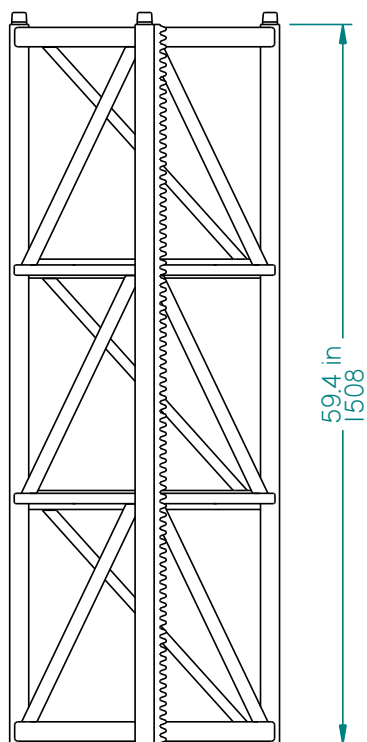

**48 Kg**  
**[106 lb]**

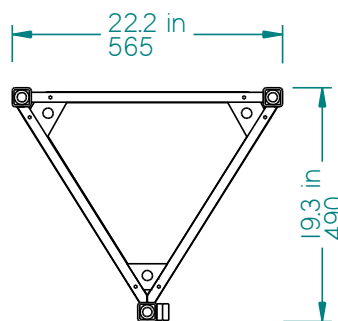

**MAST SET**



**30 Kg**  
**[66 lb]**

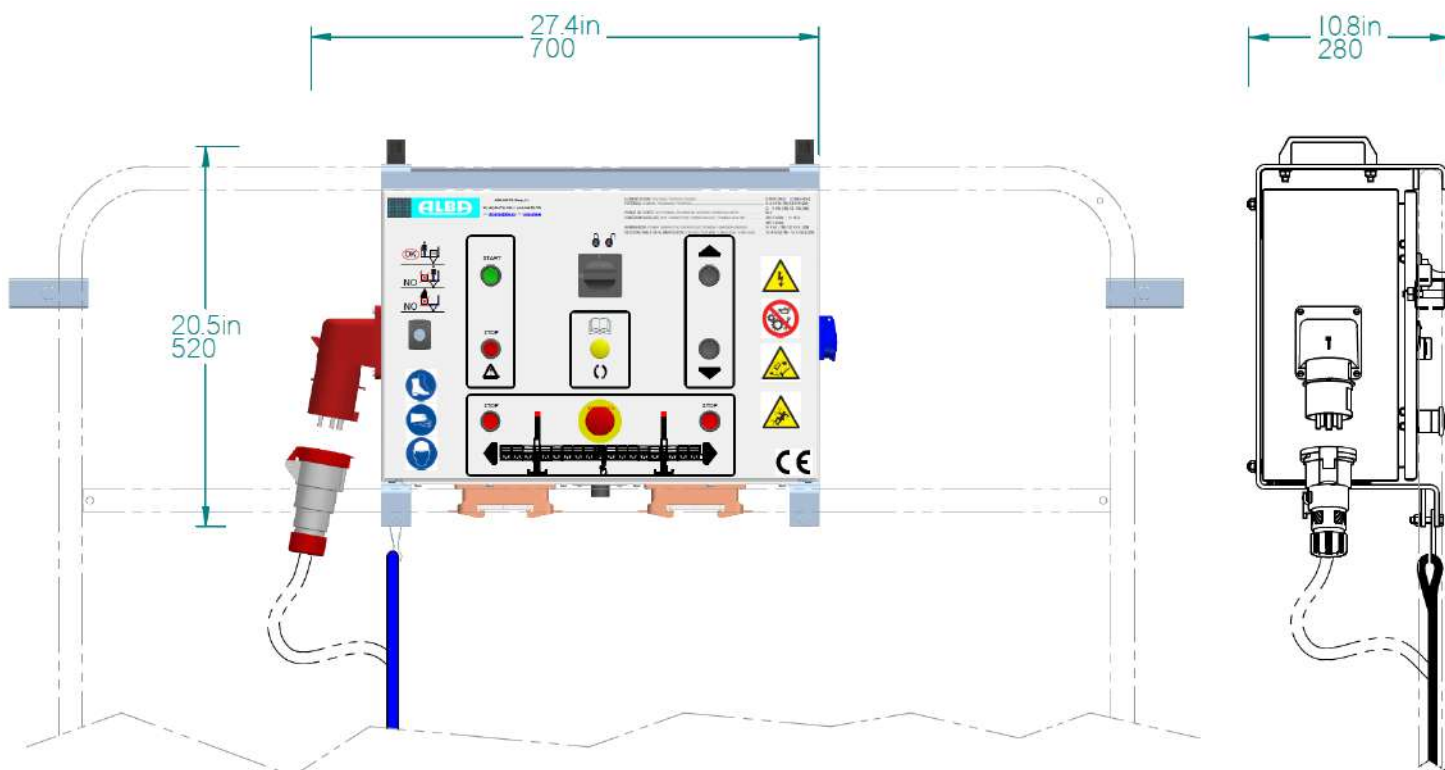

**CONTROL BOARD SET**

### 1.6. Safety devices of platform

- a) Geared motors with **electromagnetic brakes** (friction type) capable of braking at speeds of 9 m/min [30 ft/min] (and even 25% overspeed) with a deceleration of 0.1 up to 0.2 g. with maximum load.
- b) Rubber buffers to damp eventual frame impacts against the base.
- c) Limit switches at first mast and next to last mast. Stop the platform when reaching the lower or upper limit switches.
- d) Upper and lower safety limit switch. Operate in case of failure of upper or lower limit switches.
- e) Rear frame extension detection switches. Stop the platform when going past an anchor in case the extensions between the mast and the facade have not been removed.
- f) Inductive mast presence detectors be used mainly during mast erection.
- g) **Automatic platform levelling** instrument. Prevents the platform from being tilted during up or down travel. Redundancy to prevent failures. In case the redundant instrument operates, the platform gets blocked.
- h) Manual **Emergency down travel** in case of power outage, with speed control through centrifugal brake
- i) Railing with skirting board on the entire platform and skirting board on facade side.
- j) Non-slip steel platform deck.
- k) Open access door interlock switch. Prevents the hoist from starting with an open door.
- l) Platform access ladder. Easy and safe access to Platform.
- m) Mast protector. Prevents eventual trapping when the hoist is in motion.
- n) End mast (in red), without rack, to prevent the cage from running off in case of failure of other systems.

#### NOISE EMISSION DECLARATION

	Condition
	Control panel position
<b>A-weighted emission sound pressure level, LpAd:</b>	<b>70 dB</b>
Values determined according to the acoustic test given in EN 12159 with use of basic international standards EN ISO 3744 y EN ISO 4871.	
<b>Note:</b> Noise emission values "declared combined" are the sum of the measured values and uncertainty. Represent an upper limit of the range in which the measured values are susceptible to being present.	

## 2. ASSEMBLY OF THE MACHINE

### 2.1. Introduction.

The following section is dedicated to the safely assembly of the machine. The installation of the hoist can only be performed by TECHNICAL PERSONNEL, who have received adequate training.

**WARNING:**

**TO MOUNT THE HOIST SHALL BE USED PROTECTIVE EQUIPMENT AGAINST FALLS FROM HEIGHT, AND IN ANY CASE A PROTECTIVE HELMET FOR THE HEAD, PLUS ADDITIONAL MEANS OF PROTECTION DEFINED ON THE CONSTRUCTION SITE.**



It is important to follow the instructions described in detail, so that to avoid risks in the process of Assembly and disassembly of the machine. The user is obliged to observe, for itself, and by all those who work in the vicinity, all sources of additional risk, as well as to comply with all security standards required for the type of equipment used.

### 2.2. Transport and handle.

The work platform is supplied unassembled, in accordance with the sets that are specified in section 1.5. Also indicates the dimensions and weights of the main assemblies to be handled during installation.

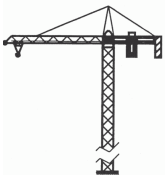
**IMPORTANT:**

**FOR ASSEMBLY OF THE COMPONENTS AND PLATFORM MOUNTING, IT IS RECOMMENDED TO USE A BUILT-IN CRANE TRUCK, OR IF AVAILABLE, THE CRANE TOWER OF THE WORK IS GOING TO BE USED.**



**IF IT'S NOT AVAILABLE, 3 PERSONS ARE REQUIRED TO HANDLE COMPONENTS.**

**2.3. Machine erection procedure:**



**IMPORTANT:**  
BEFORE STARTING PLATFORM ASSEMBLY, IS IMPORTANT TO PLAN THE PLATFORM POSITION AT THE BUILDING SITE, WITH SPECIAL ATTENTION TO:

- LENGTH AND EXPECTED PLATFORM CONFIGURATION.
- INTENDED USE FOR THE PLATFORM.
- MIN. DISTANCE TO FACADE – 20 cm [8 in].
- INSTALLATION OF AUXILIARY EXTENSIONS.
- Nº OF ANCHORS AND DISTANCE BETWEEN ANCHOR POINTS.
- INTENDED LENGHT OF ANCHOR ARMS.
- ....



**IMPORTANT:**  
CHECK THAT THE POSITION CHOSEN FOR THE INSTALLATION ALLOWS ASSEMBLY OF THE PLATFORM WITHOUT APPROACHING ANY DANGEROUS POINT IN ITS VERTICAL TRAJECTORY.

MINIMUM DISTANCE BETWEEN TWO ADJACENT WORK PLATFORM IS 0.5 m [20 in] TO AVOID RISK TO PLATFORM USERS.



IN CASE OF NEED A SPECIAL CONFIGURATION OF PLATFORM, OR MODIFICATION OF THE STANDARD FEATURES, ASK THE MANUFACTURER TO PROVIDE DRAWINGS WITH SPECIFIC DIMENSIONS AND FEATURES AND ADD IN AS ATTACHMENT TO THE ASSEMBLY PLAN.

• Step 1. Base to ground positioning

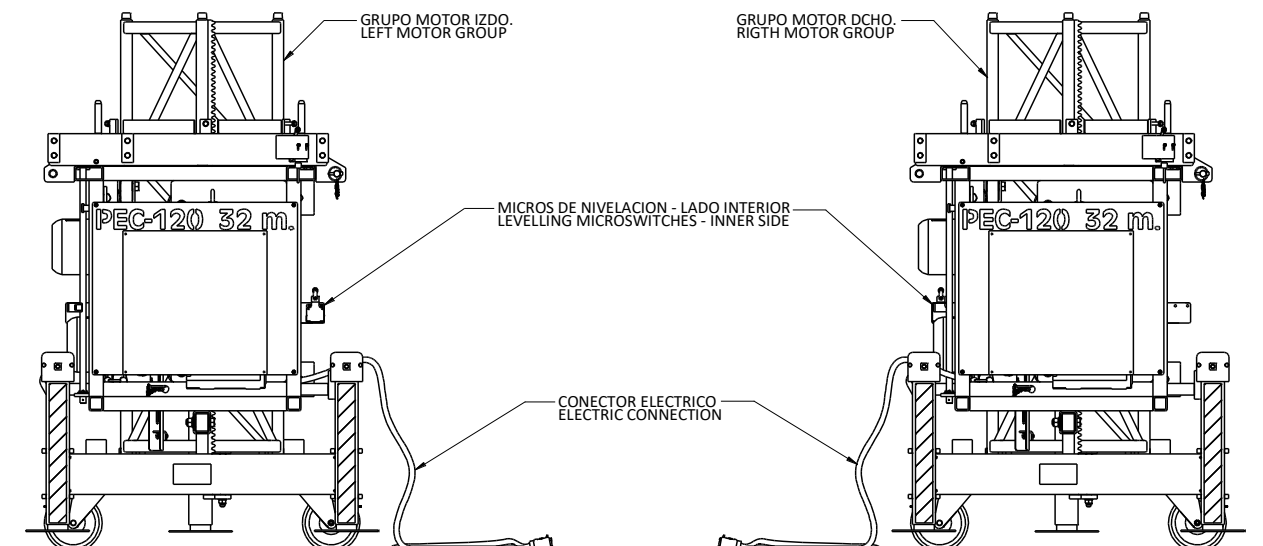

**POSITIONING BASES AT THE GROUND**



**ATTENTION:**

**PUT MOTOR GROUPS AT PLANNED INSTALLATION POINTS WITH SPECIAL ATTENTION TO THE POSITION OF THE ELECTRICAL CONNECTOR**

- **TWIN MAST: PUT MOTOR GROUP SO THAT THE LEVELING MICROS AND CONNECTORS ARE FACING THE INSIDE**  
(IN CASE THAT THE TWO GROUPS ARE THE SAME, MICROS AND CABLE OUTPUT POSITION SHOULD BE CHANGED IN ONE OF THEM)
- **SINGLE MAST: INSTALL EITHER ONE OR ANOTHER GROUP**

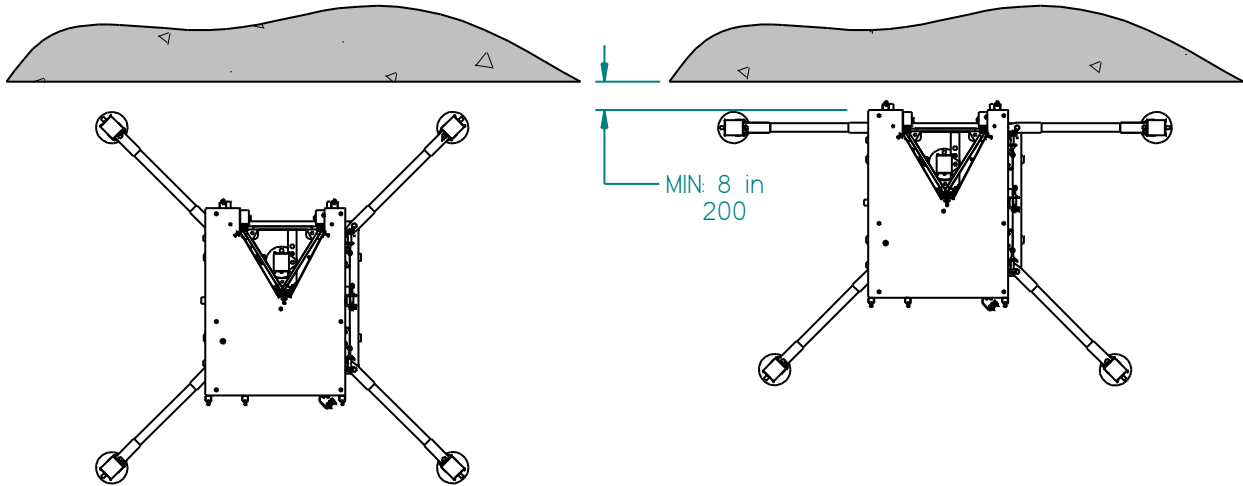

**BASE POSITIONING OPTIONS**



**ATTENTION:**

**THE BASE CAN BE MOUNTED WITH THE STABILIZERS IN VARIOUS POSITIONS. IF POSSIBLE, CHOOSE THE POSITION OF THE JACKS MORE SEPARATED. IF STABILIZERS ARE NOT INSTALLED, THE FIRST ANCHOR IS TO BE MOUNTED AT 2 m [3.3 ft].**

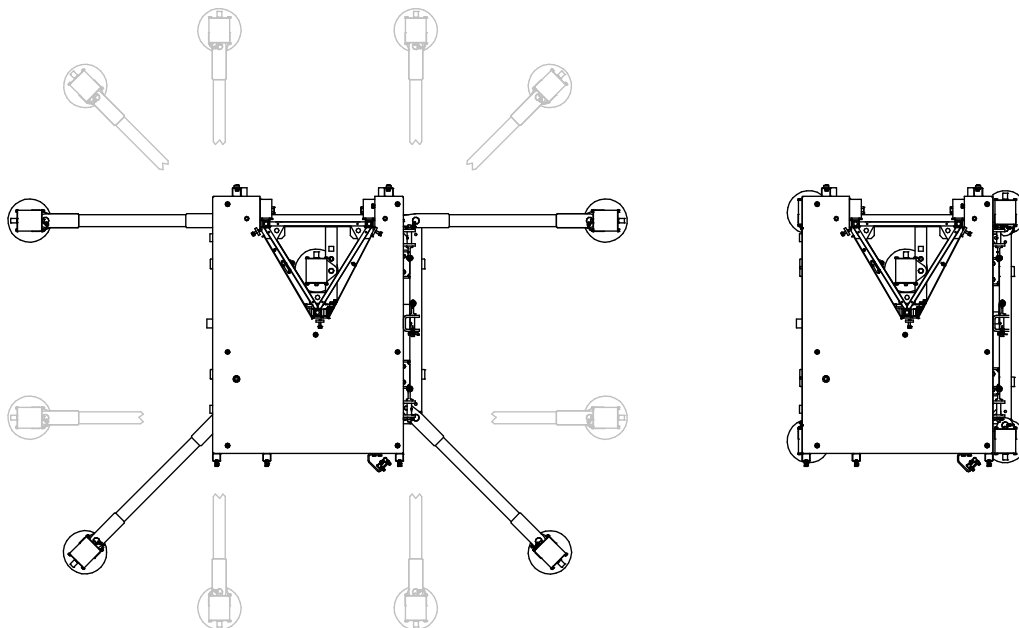

**ASSEMBLY WITH STABILIZERS**

**ASSEMBLY WITHOUT STABILIZERS**



**IMPORTANT:**  
**CHECK THE RESISTANCE OF SOIL TO WITHSTAND MAXIMUM LOADS TRANSMITTED TO GROUND BY THE PLATFORM DURING OPERATION.**  
**IT'S RECOMMENDED TO USE WOOD PLATES OF 40x40cm [15x15in] FOR A CORRECT SUPPORT OF THE JACKS.**  
**SPECIAL ATTENTION TO JACKS NEXT TO THE MAST, ON WHICH RESTS THE MAIN WEIGHT OF THE MACHINE, ENSURING THAT TOUCH THE GROUND PROPERLY.**

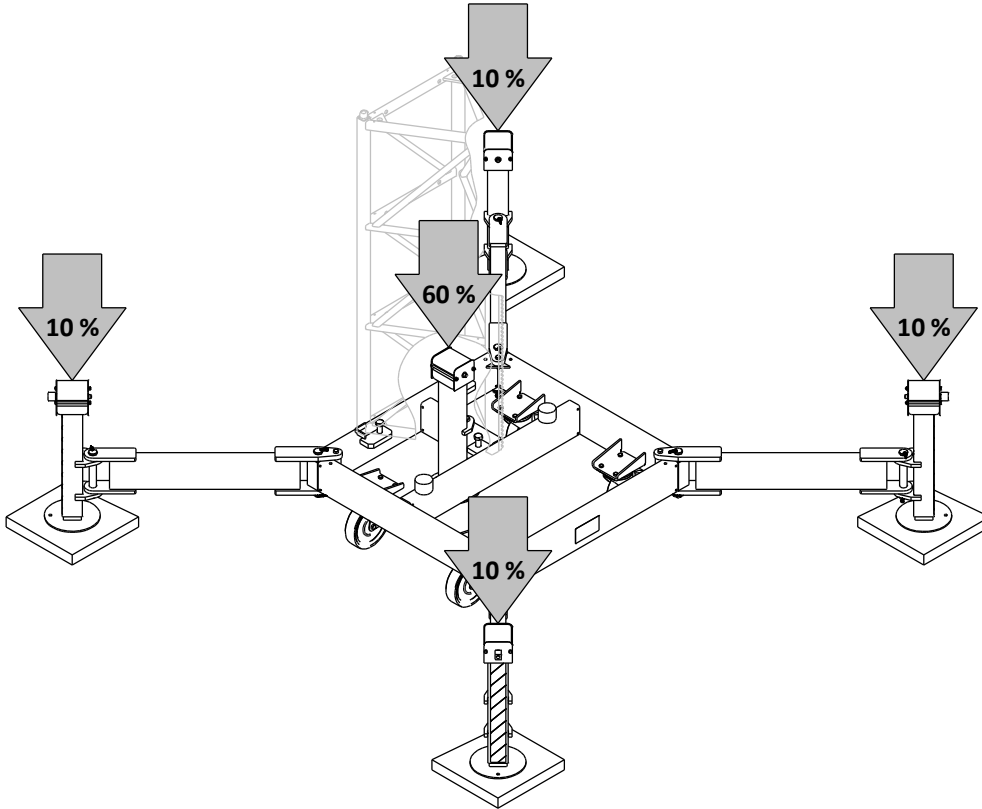

**LOADS TO GROUND DISTRIBUTION**



**IMPORTANT:**

**MAXIMUM PLATFORM LOADS TRANSMITTED TO GROUND:**

	TOTAL LOAD (EST.) [KN]	TOTAL LOAD (DIN.) [KN]
SINGLE MAST	72,5	82,5
TWIN MAST	153	175,5

(x225) = [lbf]

**USE THE ABOVE VALUES TO VERIFY THAT THE GROUND IS CAPABLE OF SUPPORTING THE LOADS TRANSMITTED AT EACH POINT.**

**CASE OF SPECIAL ASSEMBLIES, CONTACT THE MANUFACTURER.**

**GROUND RESISTANCE EXAMPLES**

MATERIAL	MAX PRESS.
CRYSTALLINE SOLID ROCK	20.000 Kg/m <sup>2</sup>
SEDIMENTARY ROCK	1000 Kg/m <sup>2</sup>
STONE OR GRAVEL	1000 Kg/m <sup>2</sup>
SAND, MUDDY SAND, MUDDY GRAVEL	700 Kg/m <sup>2</sup>
SAND, CLAY, MUD	450 Kg/m <sup>2</sup>



**ATTENTION:**

**IF IN DOUBT ABOUT THE CHARACTERISTICS OF SUPPORTING SOIL, IT'S RECOMMENDED TO USE LOAD DISTRIBUTION PLATES. IF INSTALL THE MACHINE ON A HOLLOW FLOOR OR BASEMENT ACCESSIBLE, IT'S NECESSARY TO UNDERPIN BOTTOM IN THE PLATFORM BASE AREA.**

- Step 2. Base leveling and resting on floor.

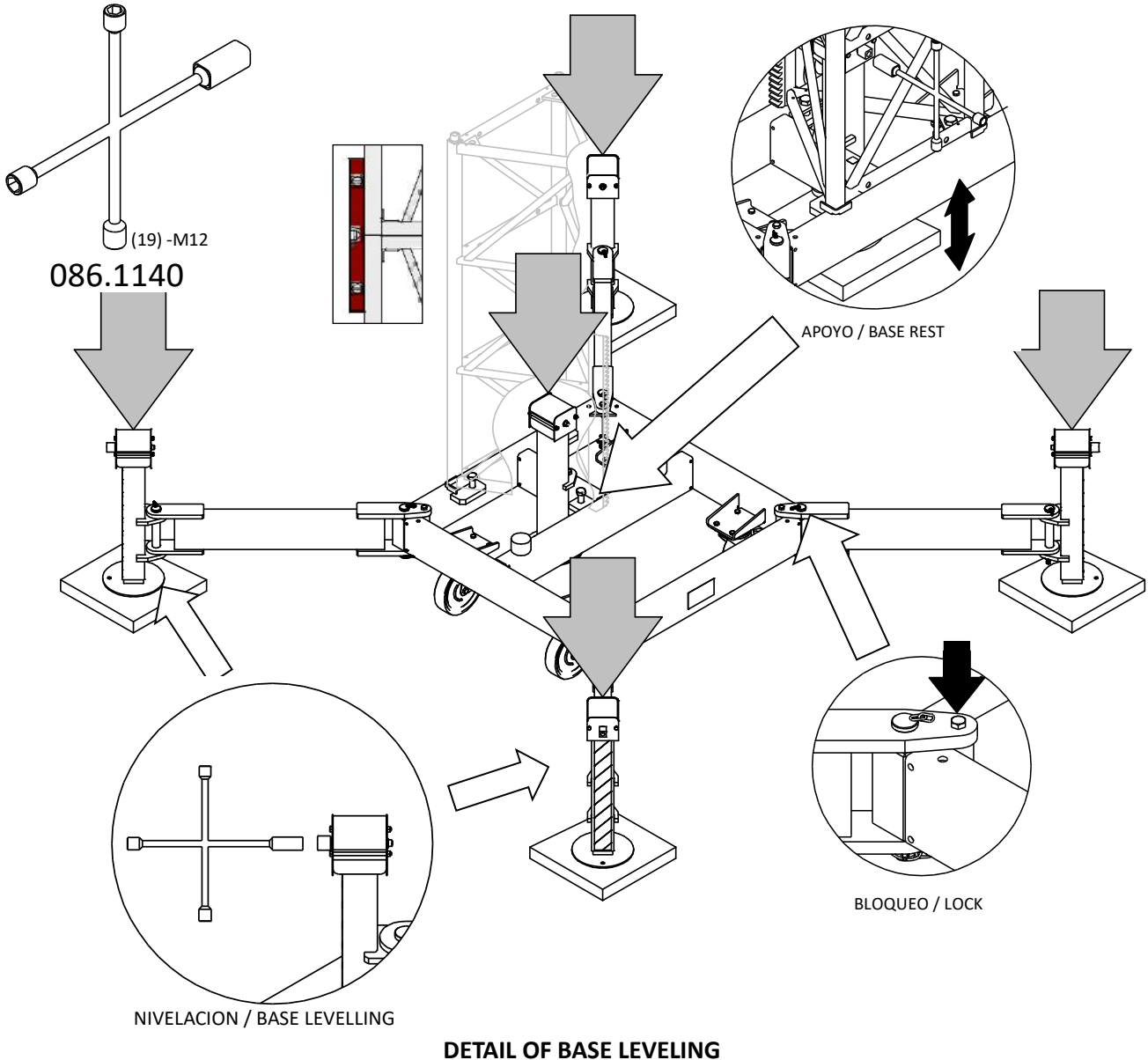

**ATTENTION:**

**LEVEL VERTICALLY PLATFORM BASE, ACTING ON THE LEVELLING JACKS. USE A SPIRIT LEVEL ALONG ON TWO PERPENDICULAR FACES OF FIRST MAST IN THE PLATFORM BASE.**



**ATTENTION:**

**ONCE PLATFORM BASE IS LEVELED, SUPPORT FIRMLY THE BASE CENTRAL JACKS. BLOCK STABILIZERS IN ITS POSITION WITH THE PIN, TO AVOID FURTHER MOVEMENT.**

• Step 3. Assembly of the platform



**ATTENTION:**

**ONCE THE BASE IS LEVELED AND CENTRAL JACK LEANING ON THE GROUND, YOU CAN START ASSEMBLY OF THE MODULAR PLATFORM.**

**ASSEMBLY OF PLATFORM: SINGLEMAST**

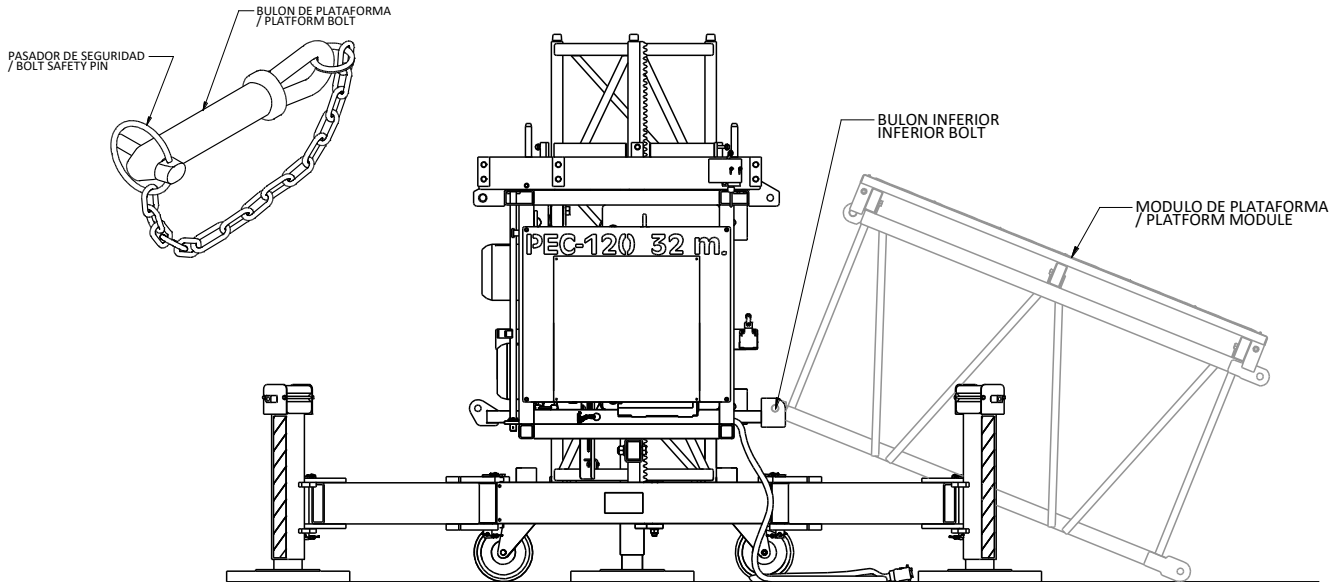

**1: INSTALLING INFERIOR BOLT**

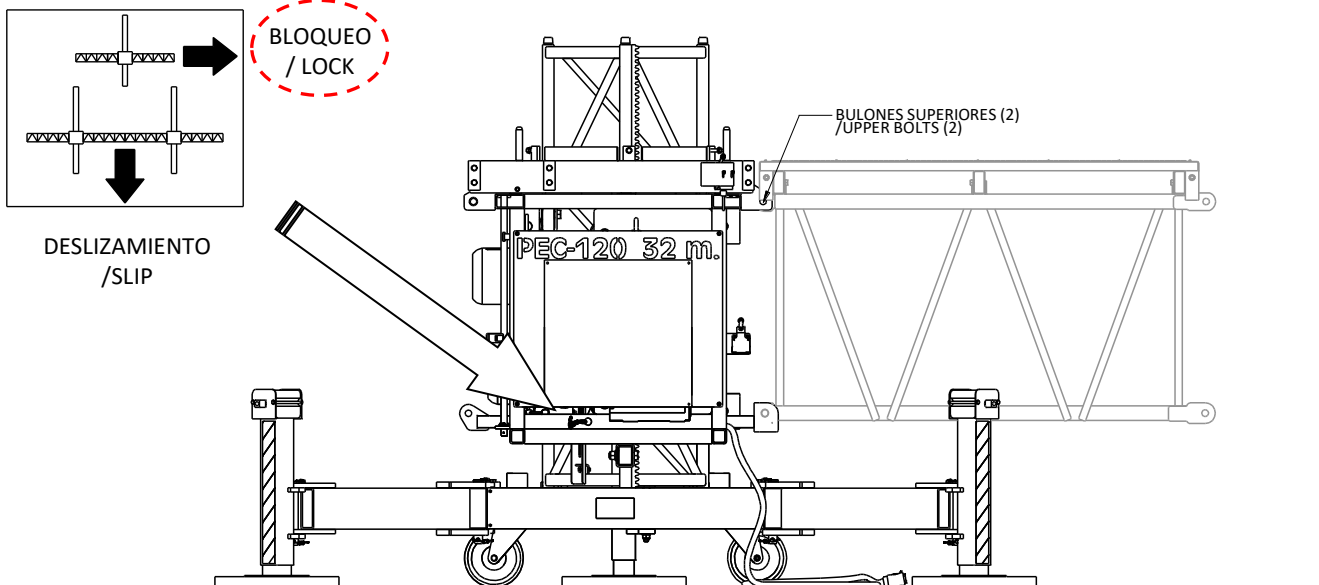

**2: INSTALLING UPPER BOLTS**



**IMPORTANT:**

**CASE OF SINGLE MAST PLATFORM, INSTALL CHASSIS BLOCKING BOLT, SO AS TO PREVENT FREE MOVEMENT OF THE BOTTOM CHASSIS ARM.**

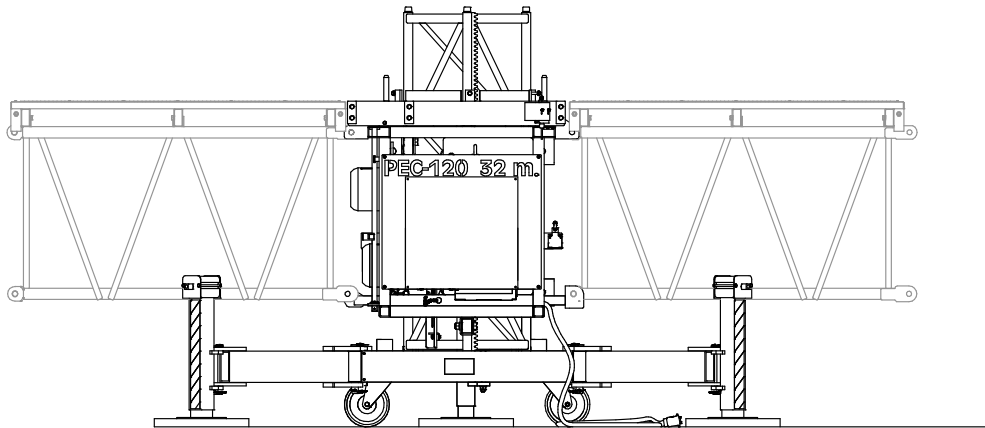

### 3: MONTAJE SIMETRICO DE LAS PLATAFORMAS



**IMPORTANT:**  
 COMPLETE ASSEMBLING MODULES ON BOTH SIDES OF THE CHASSIS GROUP  
 ALTERNATELY UNTIL DESIRED LENGTH.

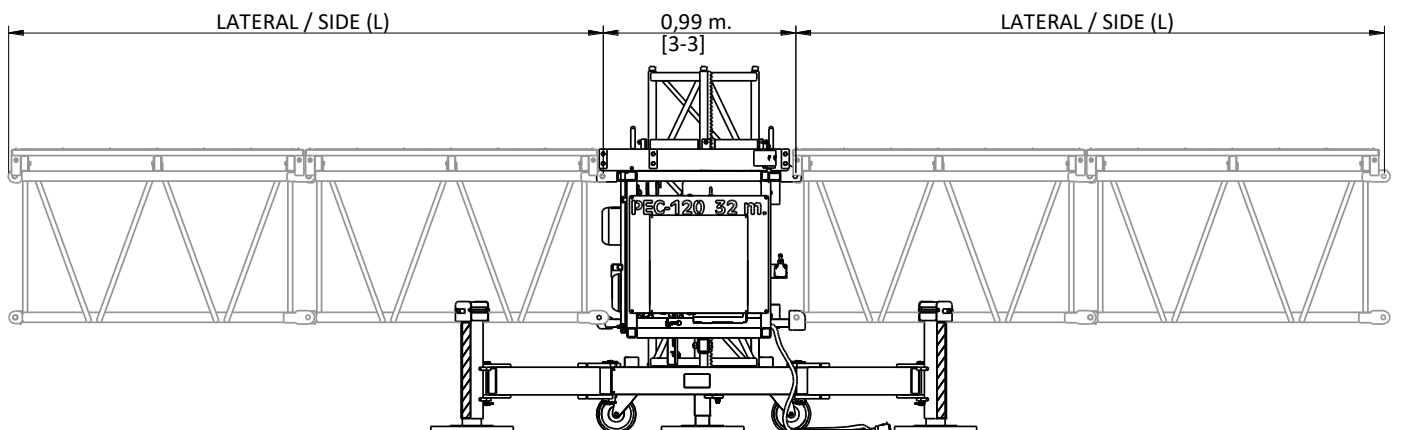

**ATTENTION:**  
 NEVER EXCEED THE MAXIMUM PLATFORM LENGTH INDICATED ON THE LOADS  
 DIAGRAM.  
 CASE OF MOUNTING A SINGLE MAST PLATFORM, IT'S NECESSARY AN INITIAL  
 CONFIGURATION WITH A MAXIMUM OF 2 + 2 MODULES AND, ONCE COLUMN OF  
 MASTS AND ANCHORS ARE MOUNTED, COMPLETE ASSEMBLY OF PLATFORM  
 MODULES TO DESIRED LENGTH. CASE OF ANCHOR DISTANCE FROM 9m [30ft] TO  
 12m [40ft], INITIAL CONFIGURATION FOR ERECTION PURPOSE MUST BE 1 + 1  
 PLATFORM MODULES (L = 4 m [13.1 ft])

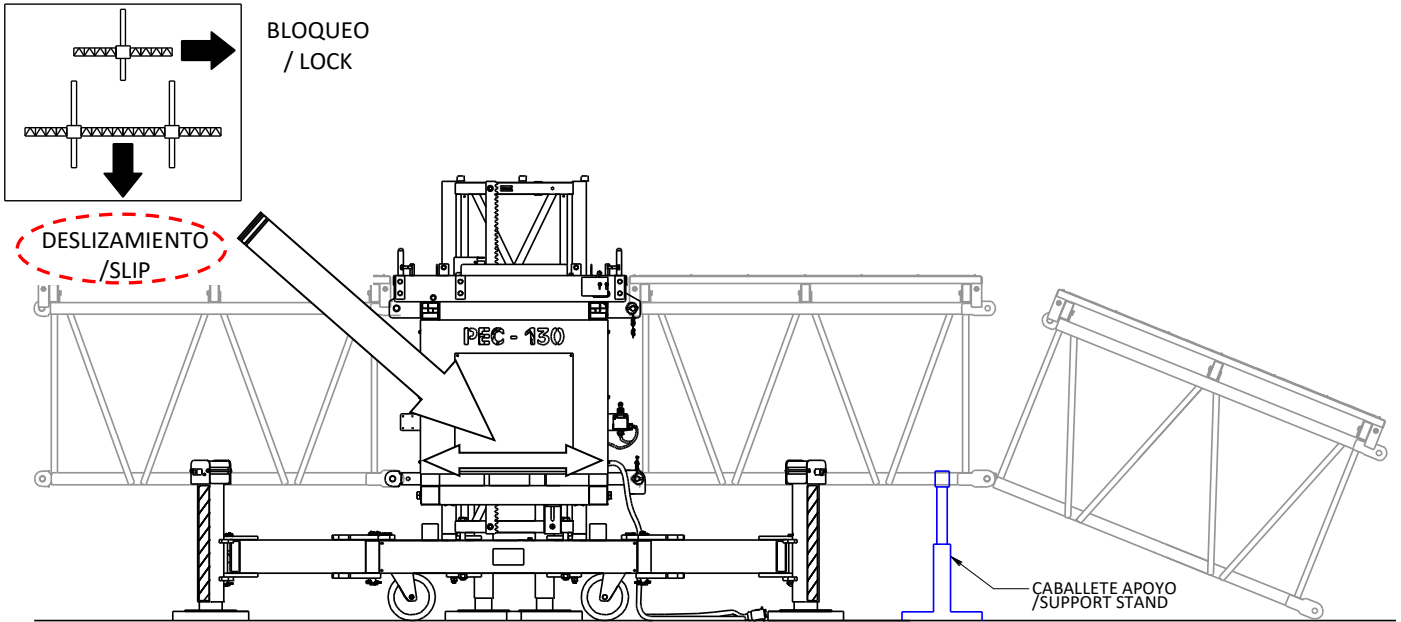

**IMPORTANT:**  
 MAXIMUM LENGTH IN SINGLE MAST CONFIGURATION IS 13m [42.7 ft]. REFER TO  
 THE LOADS DIAGRAM TO SELECT LIMITS OF LOAD DEPENDING ON ASSEMBLY  
 CONFIGURATION CHOSEN.

**ASSEMBLY OF PLATFORM: TWIN MAST**

**IMPORTANT:**

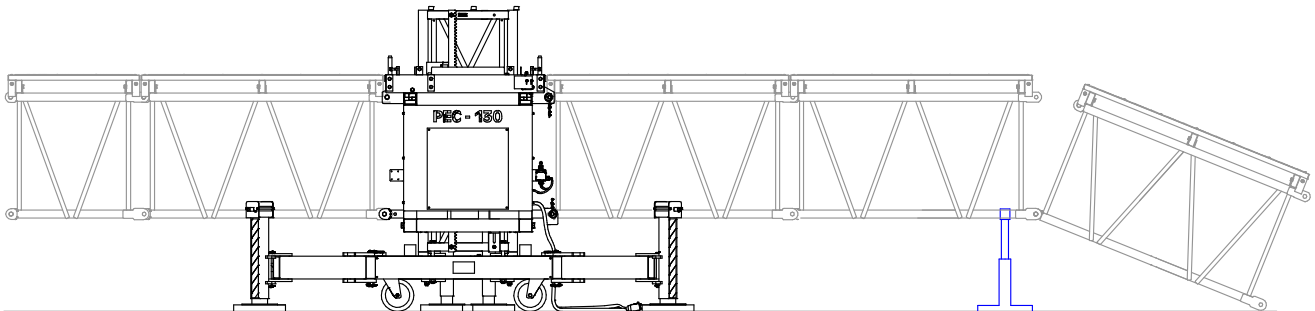
**CASE OF TWIN MAST PLATFORM, FREE THE LOCK CHASSIS BOLT, ALLOWING THE FREE MOVEMENT OF CHASSIS BOTTOM ARM.**

**ATTENTION:**

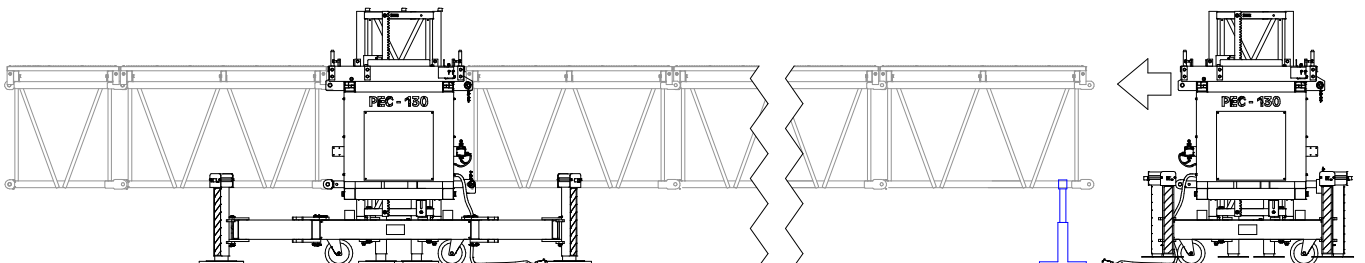
**USE AN EASEL FOR THE MOUNTING OF MODULES OF CENTRAL PLATFORM, USING IT AS A POINT OF SUPPORT TO ASSEMBLY PLATFORM MODULES. YOU CAN USE A PLATFORM MODULE REVERSED AS AN EASEL.**



**ATTENTION:**

**ONCE THE CENTRAL PLATFORM IS COMPLETED, INSTALL THE RIGHT MOTOR GROUP AND GET IT CLOSE TO THE PLATFORM TO JOIN IT UP TO THE LAST PLATFORM WITH THREE BOLTS. REMOVE THE LOWER CHASSIS GROUP BOLT.**

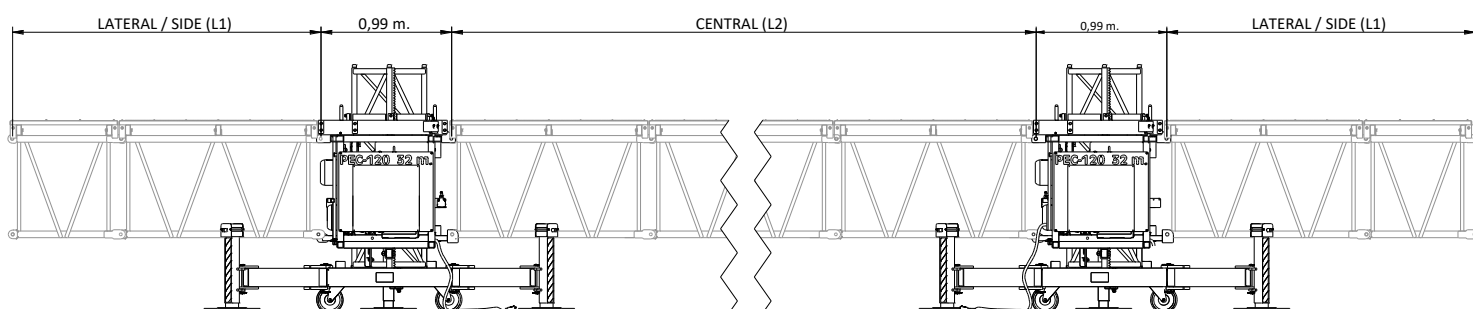

**IMPORTANT:**  
 FOR A CORRECT OPERATION OF THE PLATFORM THE RELATIONSHIP OF PLATFORMS BETWEEN THE SIDES AND THE CENTRAL BRIDGE MUST BE OF 1 TO 4. PROVIDE FOR THE CONFIGURATION LIKE SHOWN BELOW:

No OF LATERAL PLATFORM MODULES (L1)	No OF CENTRAL PLATFORM MODULES (L2)
1	From 1 to 4
2	From 5 to 8
3	From 9 to 12



FINAL CONFIGURATION OF TWIN MAST PLATFORM



**ATTENTION:**  
 COMPLETE ASSEMBLY OF THE REMAINING PLATFORM MODULES ON THE PLATFORM RIGHT SIDE. MAKE SURE THAT TWO BOTTOM BLOCKING CHASSIS BOLTS ARE OUTSIDE OF LOCKED POSITION, ALLOWING THE FREE MOVEMENT OF INFERIOR CHASSIS ARM.



**IMPORTANT:**  
 MAXIMUM LENGHT IN TWIN MAST CONFIGURATION IS 34,32 M. REFER TO THE LOADS DIAGRAM TO SELECT LIMITS OF LOAD DEPENDING ON ASSEMBLY CONFIGURATION CHOSEN.



**IMPORTANT:**  
 THE CONFIGURATION OF THE PLATFORM SHOULD BE SYMMETRICAL TO AVOID MALFUNCTION OR DAMAGE. IF IT IS NOT POSSIBLE TO INSTALL SYMMETRICAL PLATFORM CONFIGURATION, CONSULT RESTRICTIONS TO MANUFACTURER.



**IMPORTANT:**  
 TO FINISH THE ASSEMBLY OF THE WORK PLATFORM, MAKE SURE THAT ALL BOLTS AND THEIR SAFETY PINS ARE PROPERLY INSTALLED.

ALSO MAKE SURE THAT THE BASES ARE VERTICALLY LEVELED AND CENTRAL JACKS REST ON THE FLOOR PERFECTLY

• Step 4. Assembly of handrails, door and ladder



**ATTENTION:**  
**INSTALL GUARDRAILS AROUND THE PERIMETER OUTSIDE OF THE PLATFORM. LOCK INTO POSITION WITH FIXING SCREWS. INSTALL EXTREME HANDRAILS, USING THE NUTS AND BOLTS OF UNION OF PLATFORMS AND ANCHORING WITH A CLAMP TO SIDE HANDRAIL.**

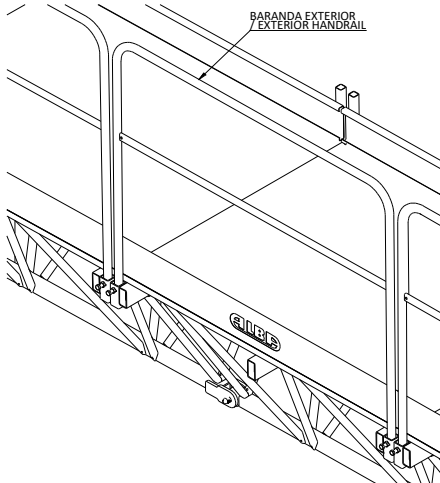

INSTALLING HANDRAILS

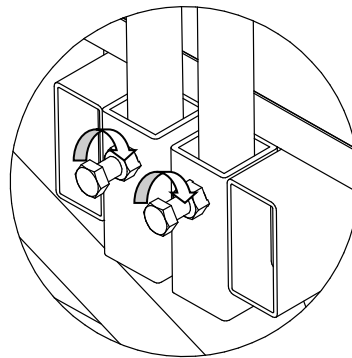

FASTENING HANDRAILS

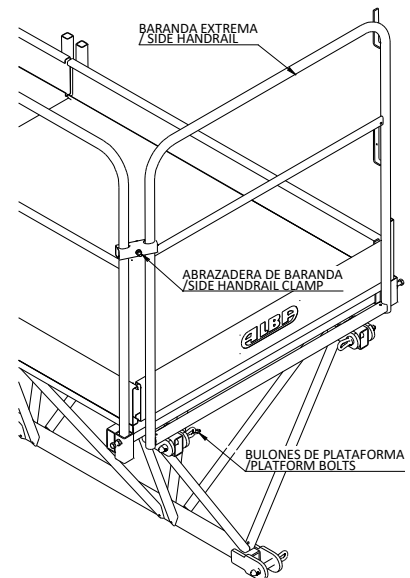

EXTREME HANDRAIL



**ATTENTION:**  
**MOUNT THE ENTRANCE LADDER AND TIGHTEN FIXING SCREW TO CHASSIS. FINALLY FIT THE DOOR INTO POSITION AND FIX FASTENING SCREWS. COMPLETE ASSEMBLY BY ADJUSTING DOOR SWITCH.**

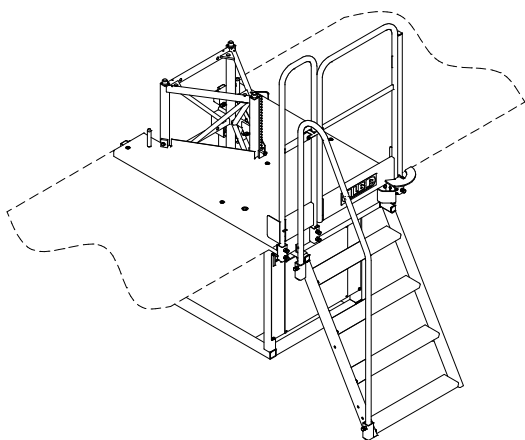

INSTALLING PLATFORM DOOR

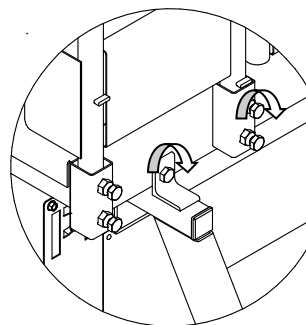

FASTENING DOOR  
 ADJUSTING DOOR  
 SWITCH

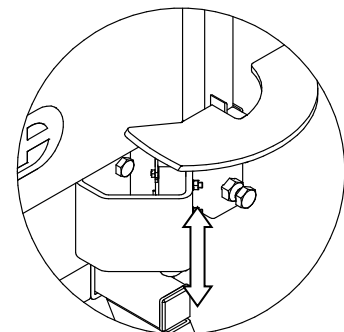

INSTALLING LADDER

- Step 5. Assembly of floor extensions and inner side perimeter protection.



**IMPORTANT:**

**ONCE MOUNTED PROTECTION ON THE EXTERIOR OF THE PLATFORM PERIMETER, PROTECTION MUST BE INSTALLED IN THE INNER AREA.**

**THE PLATFORM ALLOWS THE INSTALLATION OF AUXILIARY MODULAR FLOOR EXTENSIONS ON THE INNER SIDE.**

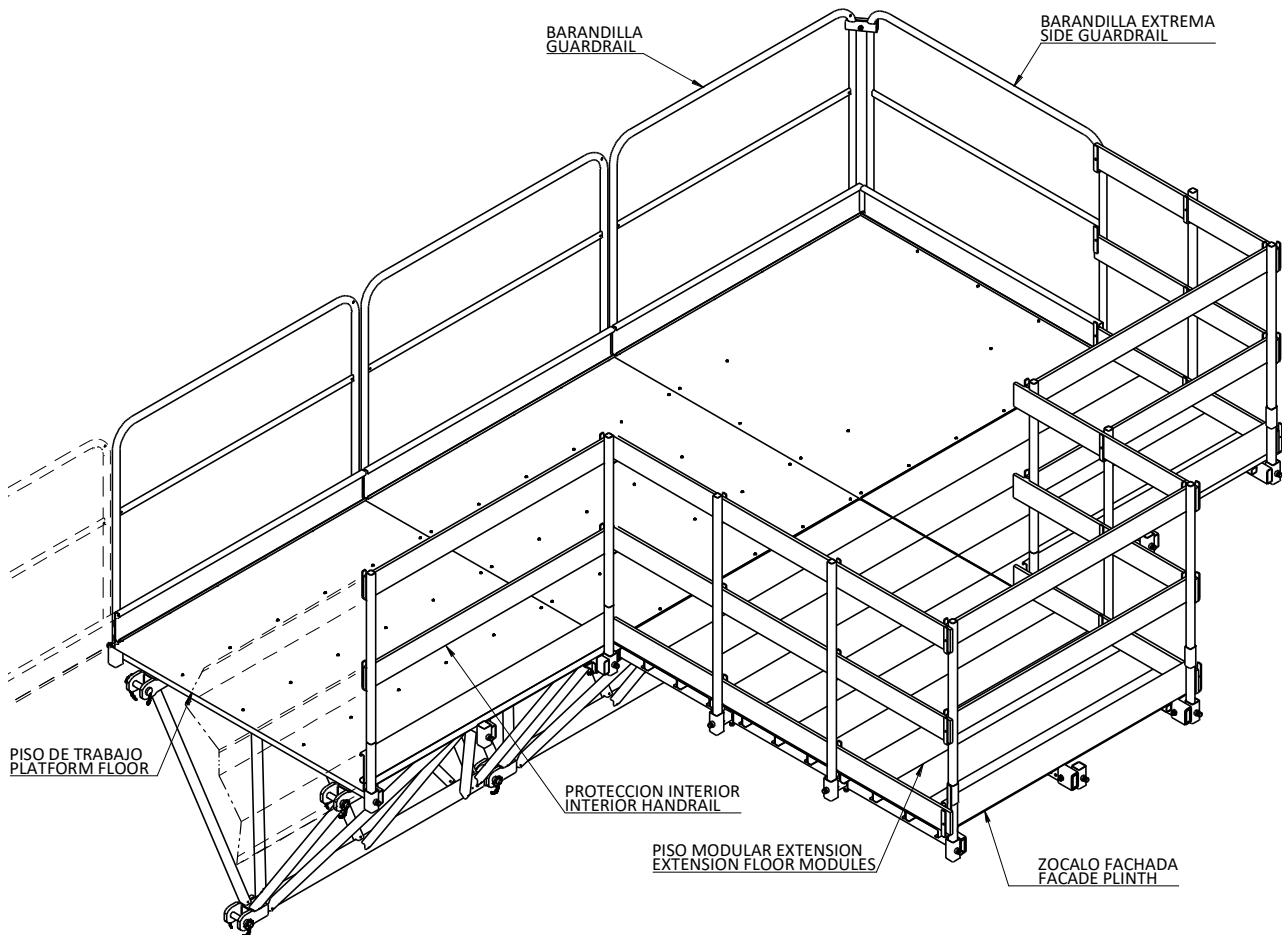

**PERIMETER ENCLOSURE OF THE PLATFORM**



**IMPORTANT:**

**INSTALL THE MODULAR FLOORS EXTENSION, AND SUBSEQUENTLY PROTECTION AT THE INNER SIDE OF THE PLATFORM, SO THERE´S NO DANGEROUS GAPS FOR USERS OF THE PLATFORM. INSTALL ADDITIONAL POSTS TO PROTECT THE SIDES OF THE EXTENSION FLOOR.**



**IMPORTANT:**

**MODULAR FLOORS MUST BE INSTALLED ADJUSTING FIRMLY IN THE EXTENSION SUPPORTING TUBES, FOLLOW THE STEPS:**

- 1. EXTRACT EXTENSIBLE, AT MOST UNTIL THE STOP SCREW.**
- 2. PLACE MODULAR FLOORS VERY TIGHT ONE ON EACH OTHER**
- 3. BLOCK THE MOVEMENT OF EXTENSION TUBES.**
- 4. FIT EXTENSION FLOOR TUBE TO EXTENSION SUPPORT TUBE WITH BRIDLES**

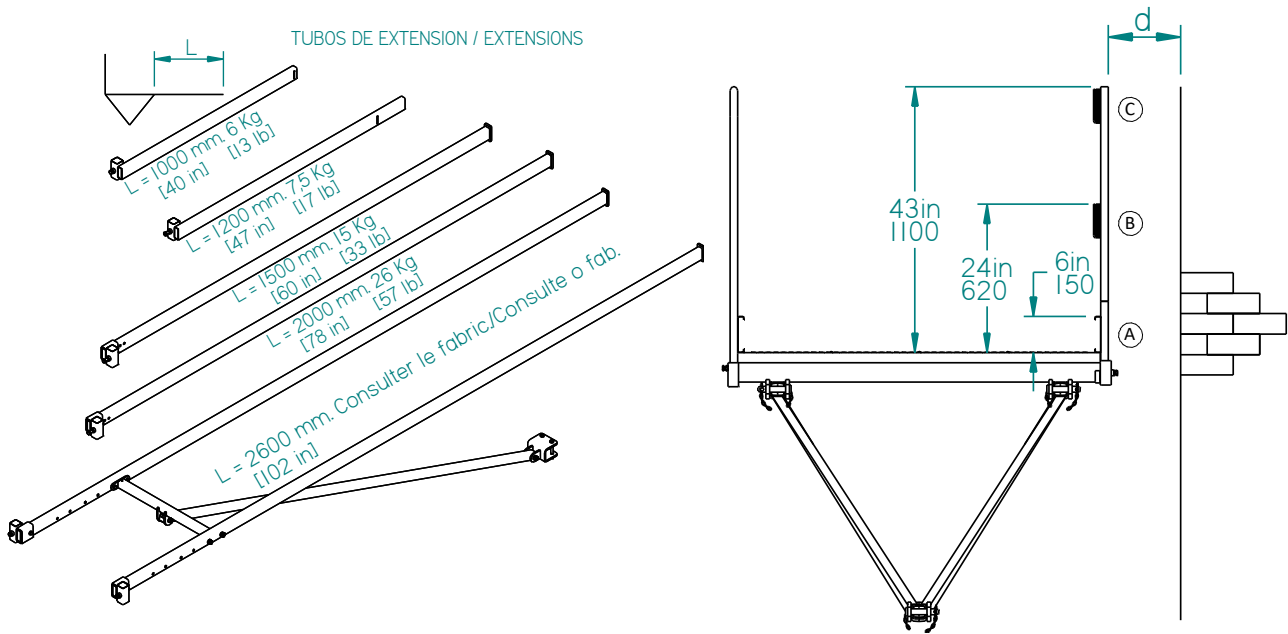
**DISTANCE TO FACADE AND INNER PROTECTION**

PROTECTION	A	B	C
If $d < 0,35 \text{ m}$ [14 in]	0	0	0
If $d > 0,35 \text{ m}$ [14 in]	X (*)	X	X (*)
If $0,35 \text{ m}$ [14 in] $< d < 0,45 \text{ m}$ [18 in]	0 (**)	0 (**)	0 (**)

 (\*) Case of  $d > 0,35 \text{ m}$  [14 in]. protections A+B+C can be replaced with a standard handrail

(\*\*) Only for plastering and lathing operations

**EXTENSION INSTALLING OPTIONS – ACCORDING TO ANSI/SAIA A10.4**

**IMPORTANT:**
**ALWAYS RESPECT THE INDICATIONS OF THE TABLE TO AVOID THE RISK OF FALLING OF THE WORKERS OR MATERIALS FROM THE PLATFORM.**
**INSTALL THE PLATFORM TO A DISTANCE MINIMUM OF 20cm [8 in] OF FACADE, TO AVOID THE RISK OF HITTING WITH THE STRUCTURE OF BUILDING.**

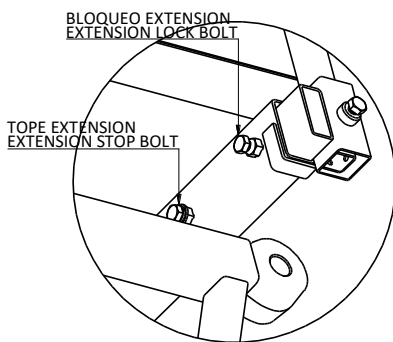
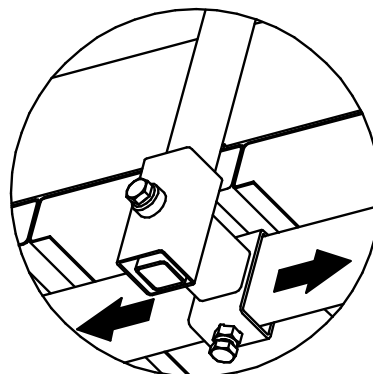
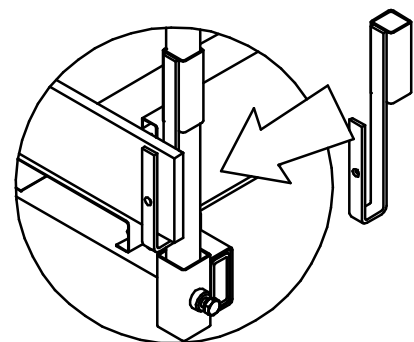
**IMPORTANT:**
**DON'T USE AS AUXILIARY EXTENSIONS FLOOR DIFFERENT OTHER THAN THOSE SUPPLIED BY MANUFACTURER.**

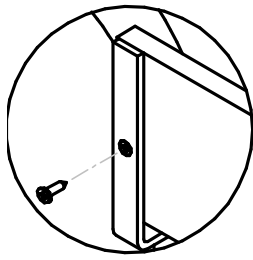
**EXTENSION TUBE  
STOP AND BLOCKING**

**LATERAL POST SUPPORT  
086.4810**

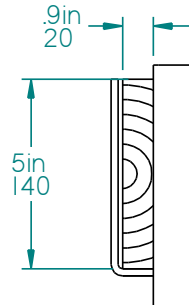
**LATERAL PLINTH SUPPORT  
086.405**

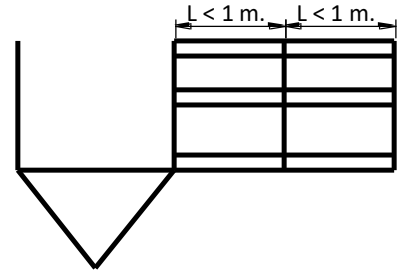

FITTING WITH SCREWS



FIXATION PLANK (CLIENT)



MAX. POST DISTANCE

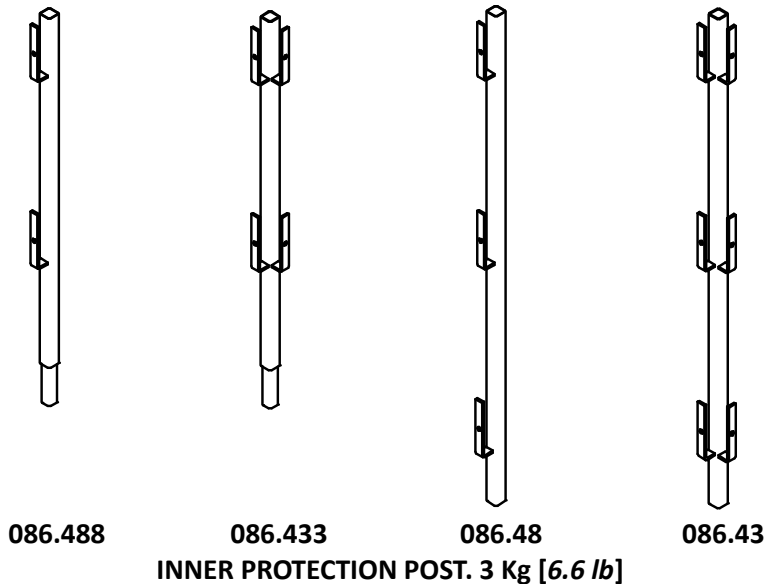
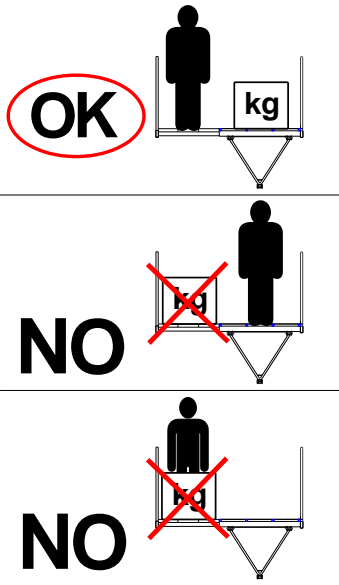

**IMPORTANT NOTES ABOUT USING EXTENSIONS:**

- MODULAR FLOORS ARE AUXILIARY EXTENSION, AND ONLY USE FOR WORK IT IS ALLOWED FOR PEOPLE AND THEIR EQUIPMENT.
- DURING THE MOVEMENT OF PLATFORM, THE USERS THAT WORK IN THE EXTENSIONS IS TO BE LOCATED IN THE MAIN PLATFORM.
- EXTENSION TUBES OF SPECIAL LENGTHS SHOULD BE USED WITH EXTREMELY CAUTION, DUE TO THE INCREASE IN SIZE OF PLATFORM THAT PRODUCE.
- IN ANY CASE, IT RECALLS THAT AUXILIARY EXTENSIONS AND ALL THEIR ACCESSORIES, SUCH AS HANDRAILS, POSTS, ... IS COUNTED AS PAYLOAD, AND ITS WEIGHT MUST BE DEDUCTED FROM LOAD CAPACITY OF THE PLATFORM FOR EACH CONFIGURATION. THE NEW LIFTING CAPACITIES MUST BE REGISTER ON THE MCWP HANDOVER CERTIFICATE
- WHEN REQUIRING A CHANGE IN THE CONFIGURATION OF THE PLATFORM, ONCE EXTENSIONS ARE INSTALLED, SUCH MODIFICATION MAY ONLY BE PERFORMED SAFELY BY AUTHORIZED PERSONNEL. THE CHANGE AND THE NEW LOAD CAPACITY MUST BE REPORTED ON THE MCWP HANDOVER CERTIFICATE.
- IN CASE OF DOUBT REGARDING THE USE OF EXTENSIONS AND CORRECTED LOAD CAPACITY, CONSULT THE MANUFACTURER.

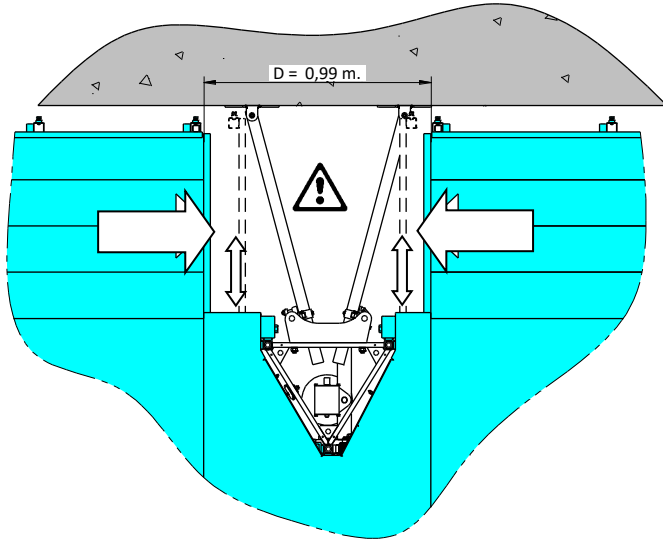

**ATTENTION:**

**IF NECESSARY, EXTENSIONS CAN BE INSTALLED IN THE BACK ZONE OF MAST. TO AVOID DANGER OF BEATING WITH ANCHOR ARMS, INSTALL ANCHOR ARMS DETECTION CAMS 086.392, AND MOTOR GROUP EXTENSION FLOORS 086.373**



**REAR ZONE OF MAST COLUMN**

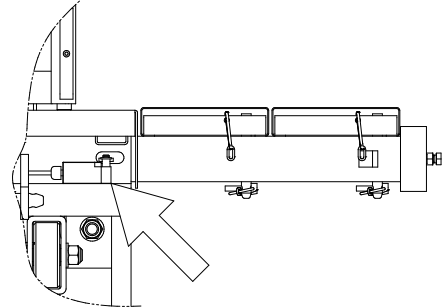

**EXTENDED EXTENSION TUBE MICROSWITCH**

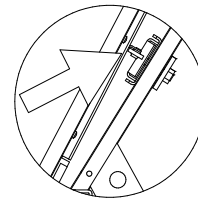

**ANCHORAGE ARMS MICROSWITCH**

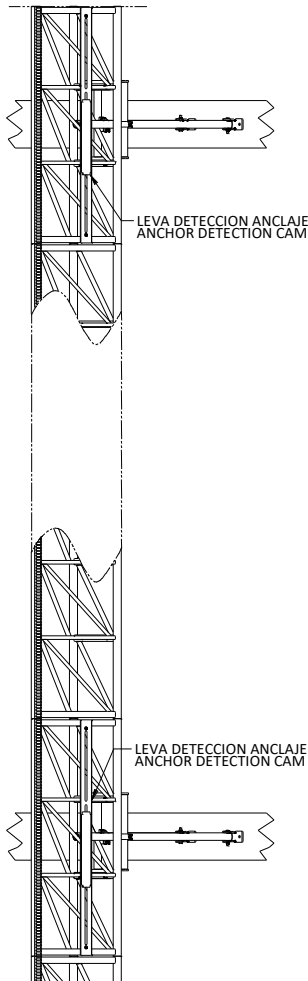

**ANCHOR CAMS 086.392**

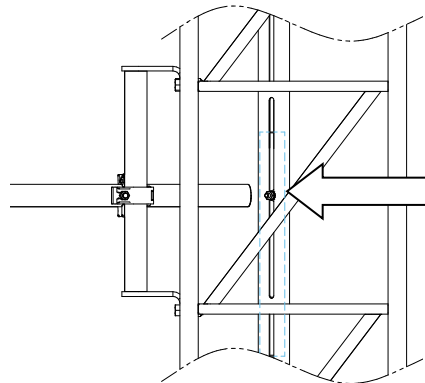

**ADJUSTING ANCHOR CAM**

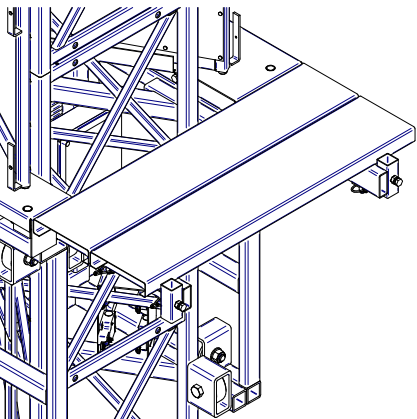
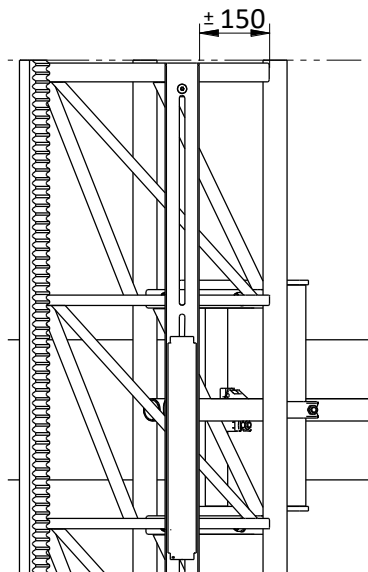

**REAR EXTENSION FLOORS 086.373**

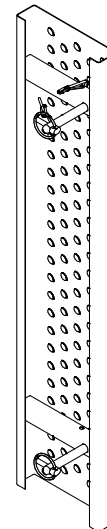

• Step 6. Electrical equipment connection.



**IMPORTANT:**

**INSTALL THE CONTROL PANEL ON THE HANDRAIL AT A POINT FROM WHICH YOU HAVE THE BEST VIEW OF THE COMPLETE PLATFORM, PREFERABLY IN CENTRAL ZONE.**



**IMPORTANT:**

**CONNECT THE ELEVATOR TO A POWER SOCKET WITH MAGNETOTHERMAL AND DIFFERENTIAL PROTECTION AVAILABLE. THE CONNECTION ONLY BE CARRIED OUT BY QUALIFIED TECHNICIANS.**

**INSTALLATION ELECTRICAL DATA**

	<b>60 Hz</b>
CONNECTION:	460 V
POWER/EACH GROUP:	2 X 2,65 KW
SUPPLY POWER:	
• SINGLE MAST:	10 KVA
• TWIN MAST:	20 KVA
NOMINAL CURRENT (460V):	
• SINGLE MAST:	12 A
• TWIN MAST:	24 A
CROSECTION WIRE	
• SINGLE MAST:	4 X 4 mm <sup>2</sup> [AWG 11]
• TWIN MAST:	4 X 6 mm <sup>2</sup> [AWG 9]
MAGNETOTHERMAL PROTECTION (*)	32 A
DIFFERENTIAL PROTECTION (*)	32 A
• SENSIBILITY:	300 mA

(\*) Elements required on electric supply board on site.

Connect earth point of the base frame to a proper earth wire on site.

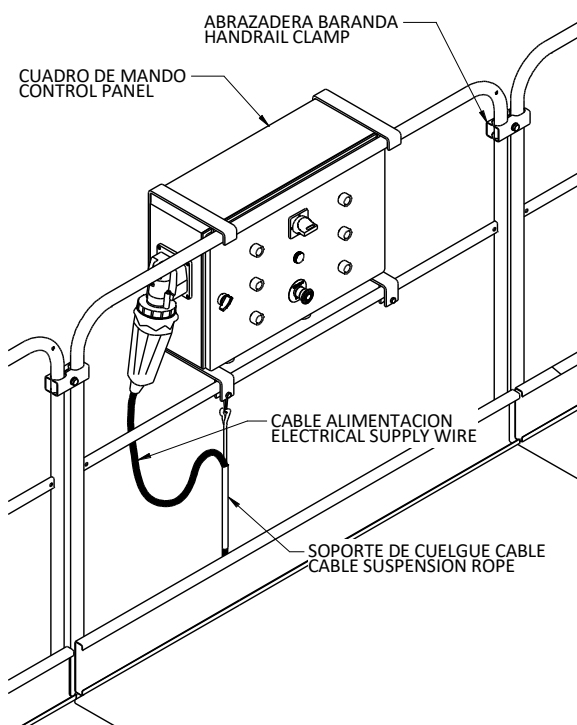

**INSTALLING CONTROL BOARD**

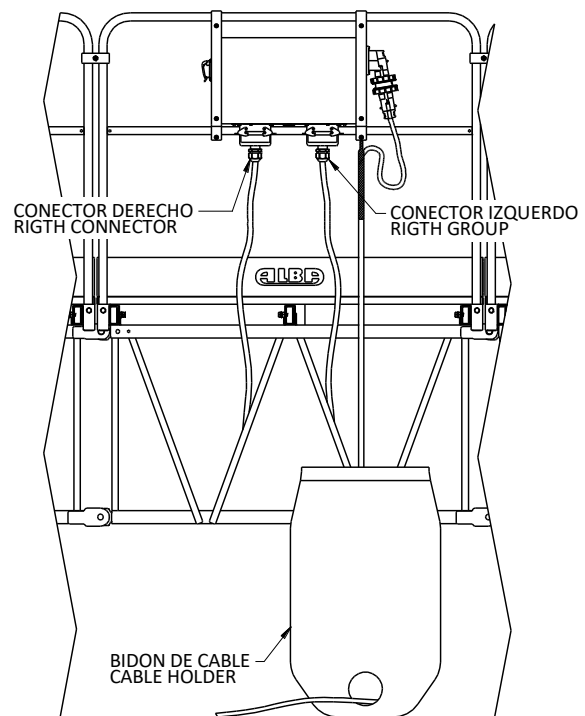

**INSTALLING CABLE HOLDER**

**IMPORTANT:**

CASE OF SINGLE MAST, CONNECT THE GROUP CONNECTOR IN ONE OF THE CONNECTORS OF THE CONTROL PANEL AND ON THE OTHER SIDE THE BRIDGE CONNECTOR. IF THE BRIDGE ISN'T INSTALLED, THE PLATFORM DOES NOT WORK.

**IMPORTANT:**

INSTALL THE CONTROL PANEL ON THE PLATFORM AT THE POINT INDICATED. IT'S NOT ALLOWED THE MOVEMENT FROM A CONTROL POINT NOT SITUATED ON THE OWN PLATFORM.

- Step 7. Adjusting leveling system.

**IMPORTANT:**

BEFORE MOVING THE PLATFORM, CHECK THAT ALL THE CABLES ARE WELL GUIDED AND FIXED WITH BRIDLES TO THE STRUCTURE OF THE PLATFORM.

**ATTENTION:**

CHECK IF THE PLATFORM IS PERFECTLY HORIZONTAL BEFORE INSTALLING THE LEVELING SYSTEM. IF THE PLATFORM IS NOT LEVELED, USE THE BUTTONS OF THE CONTROL PANEL MANUAL FOR LEVELING.

**MAXIMUM MISLEVELENT ON NORMAL OPERATION: 2°**

ONCE PLATFORM IS LEVELED MANUALLY, INSTALL AUTOMATIC LEVELING SYSTEMS AT THE POINTS INDICATED IN THE CENTRAL PLATFORM:

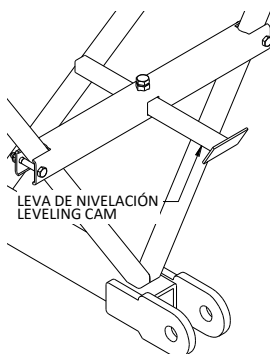
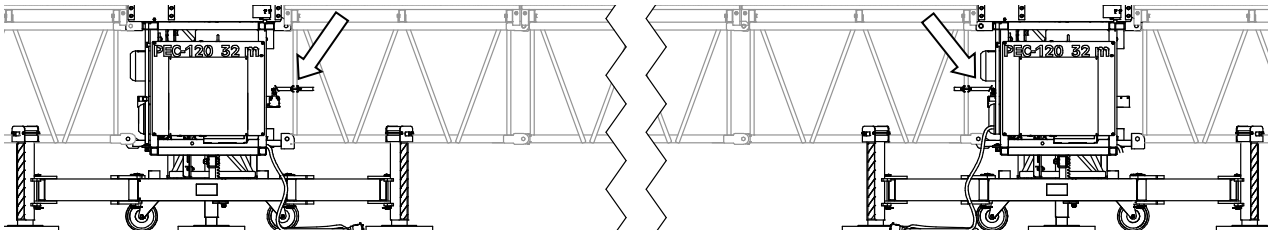

INSTALLING CAM

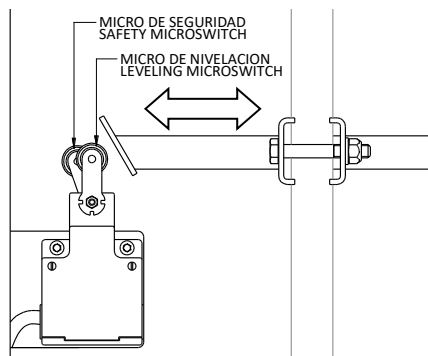

ADJUSTING DISTANCE TO SWITCH

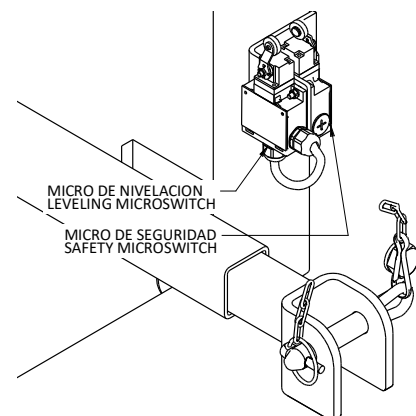

LEVELLING AND SAFETY SWITCHES

• Step 8. Assembly of mast column.



**ATTENTION:**  
SEE CHAPTER 3. USING THE MACHINE, BEFORE LIFTING THE WORK PLATFORM. MAKE SURE THAT ALL THE PERIMETER PLATFORM RAILINGS ARE INSTALLED CORRECTLY.



**ATTENTION:**  
DUE TO THE MOVEMENT OF THE PLATFORM, MAST ERECTION IS A DANGEROUS OPERATION AND MUST BE PERFORMED WITH EXTREME CAUTION. 2 PERSONS ARE REQUIRED TO ASSEMBLE THE MAST COLUMN.

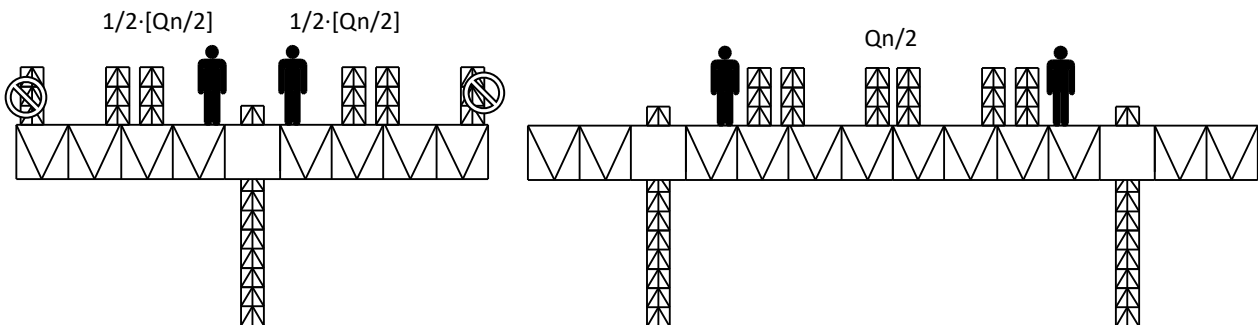

LOADS ON THE PLATFORM DURING MAST COLUMN ASSEMBLY



**ATTENTION:**  
MOUNT ON THE PLATFORM, AS CLOSE TO THE MAST AS POSSIBLE, MAST MODULES, FASTENING SCREWS AND TOOLS REQUIRED. NEVER EXCEED 50% OF THE CAPACITY OF LOAD DEPENDING ON CONFIGURATION.

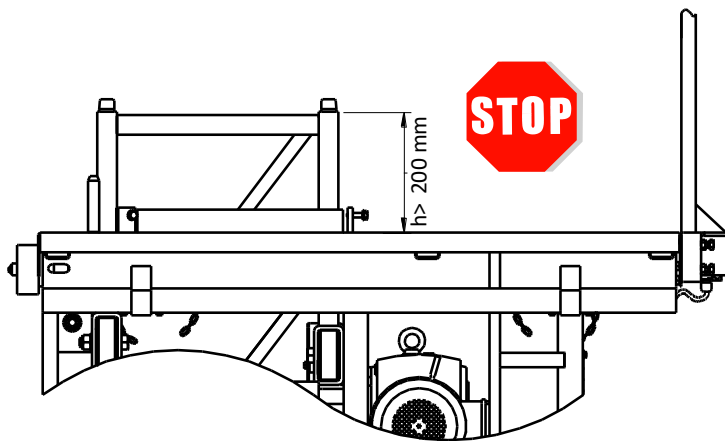

  
**200 N·m**  
**[147 lbf]**

MINIMUM CLEARANCE OF MAST

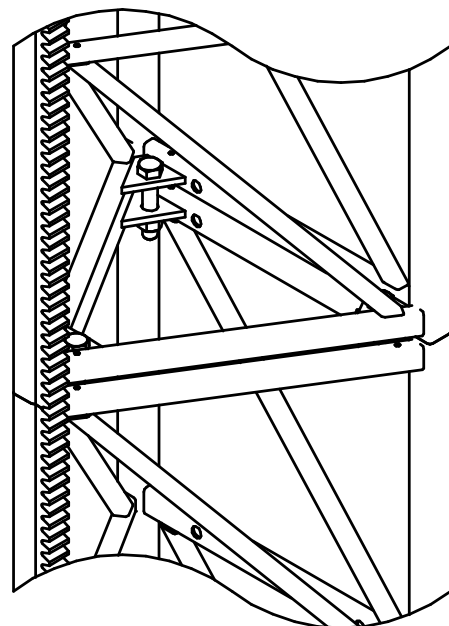

ASSEMBLY OF MAST BOLTS

**ATTENTION:**

THE WEIGHT OF THE MAST SECTION IS 48 Kg [106 lb].

USE QUALITY 8.8 SCREWS: (Max: 200 N·m)

3 X SCREW M20X90 DIN 931, WASHER A21 DIN 125 AND NUT M20 DIN 985

**CAUTION:**

FIT / REMOVE MAST AND SCREWS ALWAYS AT THE SAME TIME!

NEVER RAISE THE HOIST OVER A NON-SCREWED MAST MODULE!

THEN THERE IS A HIGH CHANCE OF COLLAPSE AND SERIOUS INJURY!



- Step 9. Assembly of mast anchorage.

**IMPORTANT:**

ANCHOR THE MAST COLUMN TO THE FACADE OR SUPPORTING STRUCTURE, MAXIMUM EACH 6 M [20 ft]. FROM 50 M [165 ft] HEIGHT AND ABOVE, THE ANCHORING DISTANCE IS REDUCED BY ALTERNATING ANCHORING EVERY 3/6 M [10/20 ft]

ABOVE 100 M [330 ft] HEIGHT, THE ANCHORAGE SHALL BE INSTALLED EVERY 3 M [10 ft].

INSTALL FIRST ANCHOR AS SOON AS POSSIBLE, FOR EXAMPLE, IN THE FIRST REINFORCED CONCRETE FLOOR OF THE BUILDING.

IF THE BASE IS INSTALLED WITHOUT STABILIZERS, DUE TO THE LIMITATION ON THE STABILITY OF THE BASE, THE FIRST ANCHOR WILL BE PERFORMED AT 2 M [6.5 ft].

CASE OF SINGLE MAST, REMEMBER TO LIMIT LENGTH OF PLATFORM ON EACH SIDE OF THE GROUP TO ASSEMBLY MAST COLUMN AND ANCHORS.

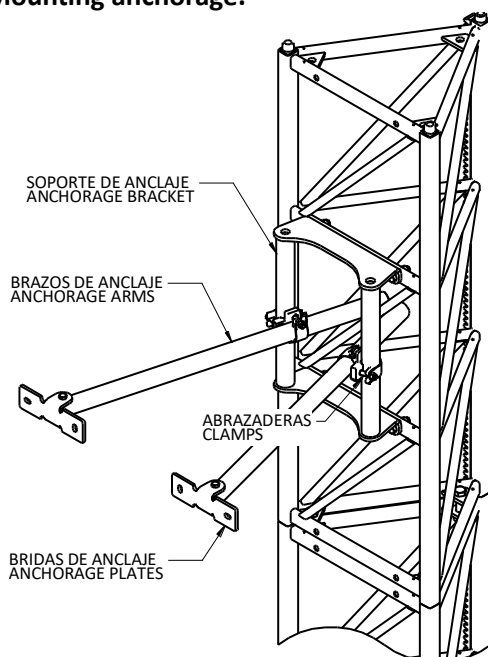
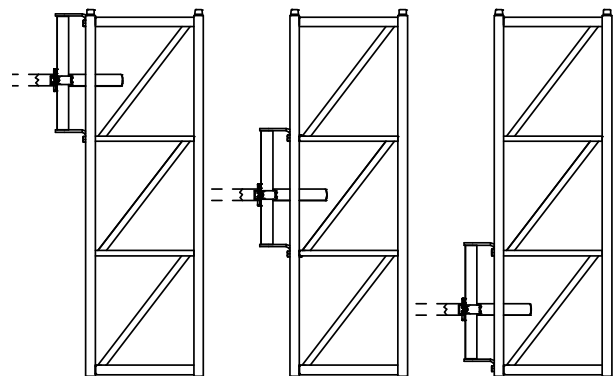
**1) Mounting anchorage.**

**MOUNTING THE ANCHOR BRACKET**

**100 N·m**

**[73 lbf]**

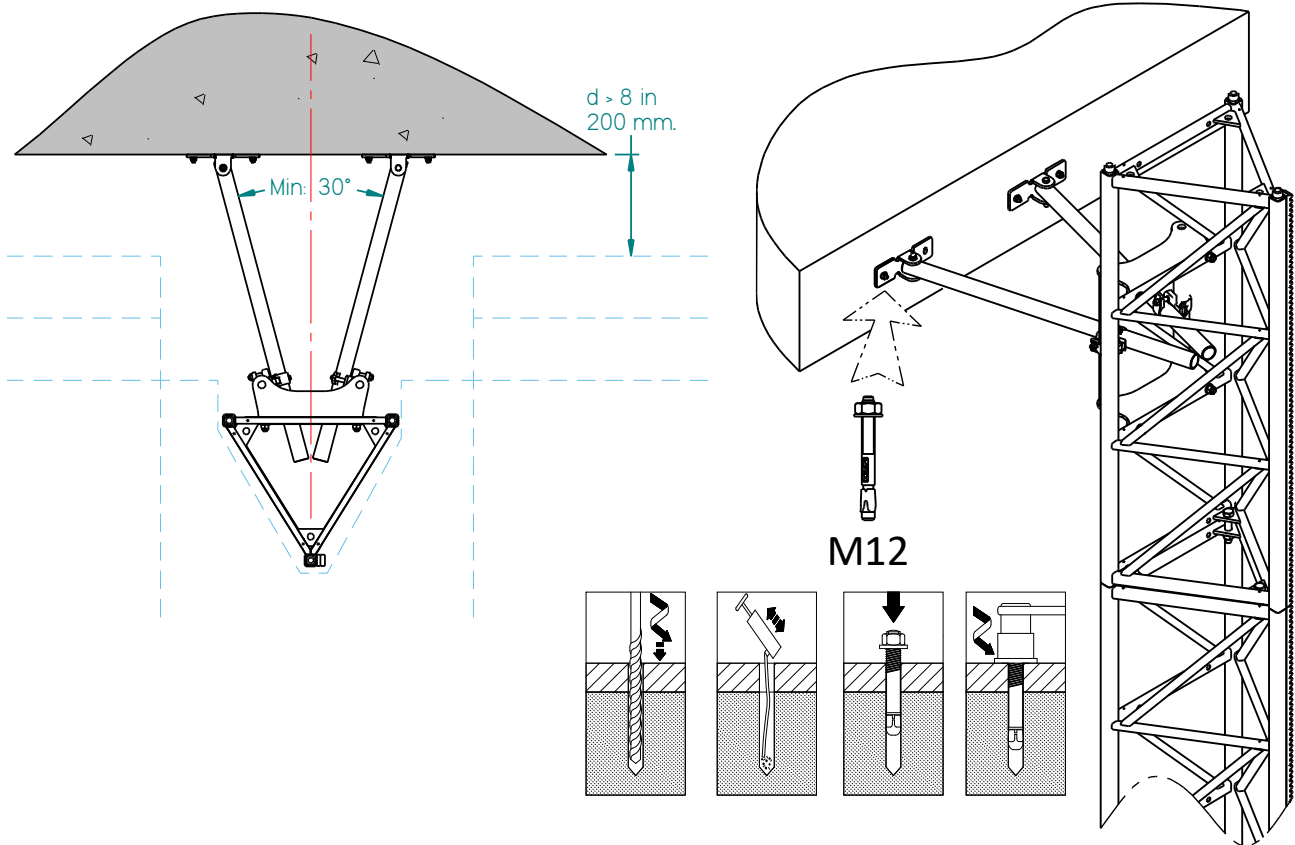
**BRACKET POSITION ALTERNATIVES**



**2) Fastening to structure.**

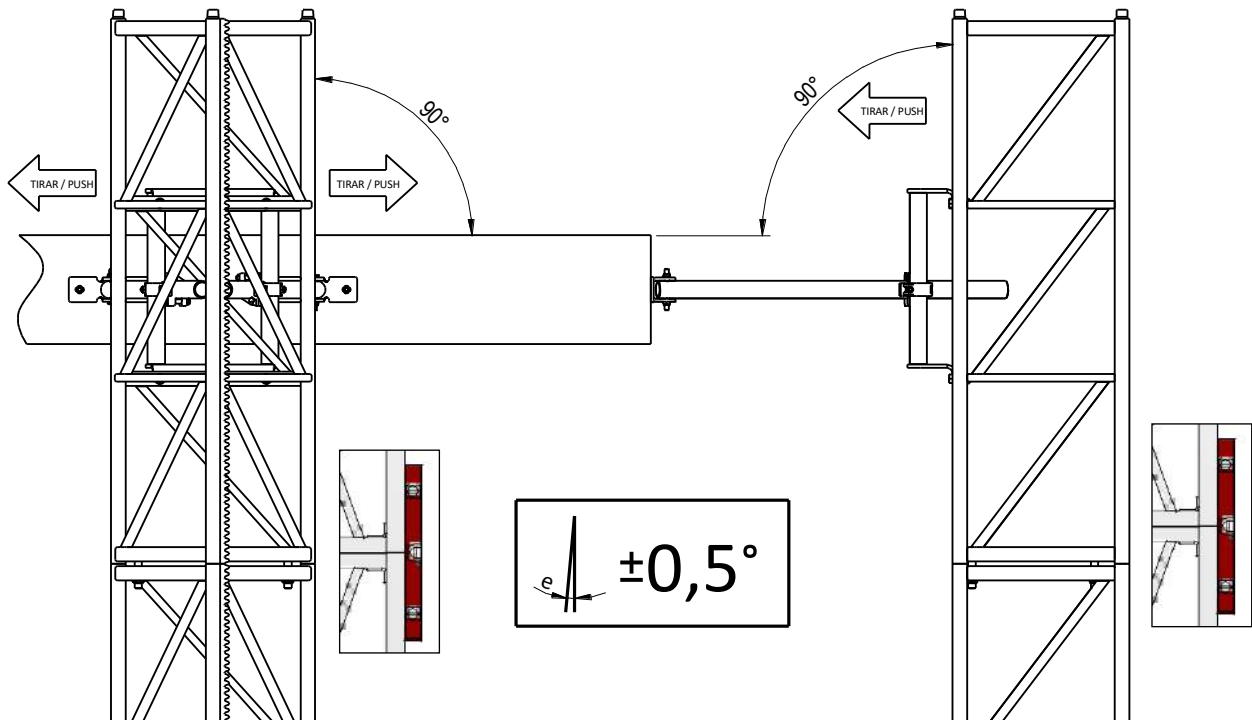

**ATTENTION:**  
**BOTH SIDES OF THE MAST MUST BE VERTICALLY 90° LEVELLED AND ALSO MAST TWISTING, BEFORE CLAMPS ARE FITTED TO THE SUPPORT STRUCTURE.**  
**USE A SPIRIT LEVEL ALONG TWO ADJACENT SIDES OF THE MAST VERTICAL TUBES.**

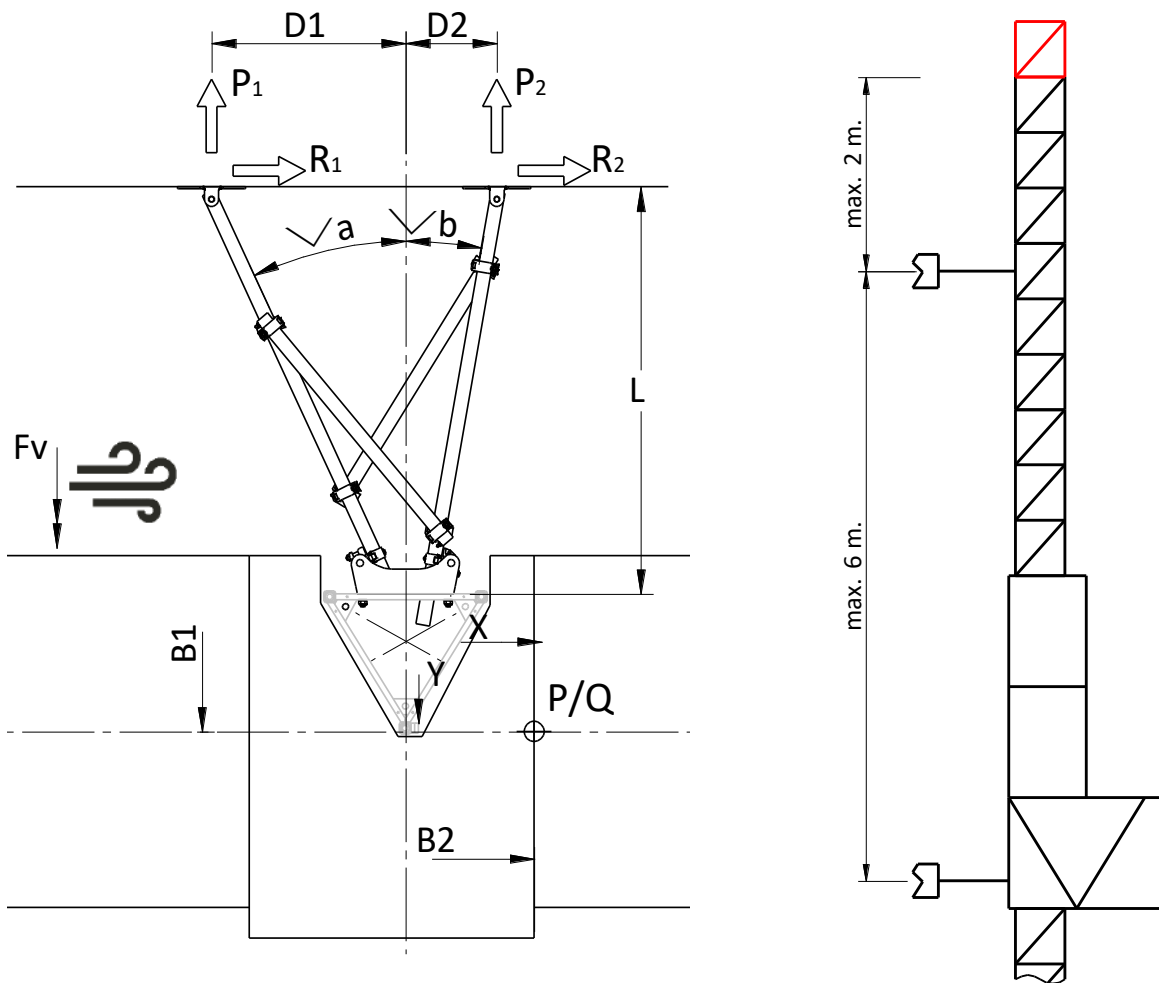
**3) Max. forces to the structure**

**IMPORTANT:**

TO TAKE INTO ACCOUNT THE EFFECT OF THE WIND IN SERVICE IN THE CALCULATION OF THE ANCHORS, A FORCE [Fv] IS ADDED TO THE VALUES RX, Ry APPLIED IN MOST UNFAVOURABLE DIRECTION (Y).

DON'T INTRODUCE PROTECTIVE SCREENS OR OTHER ELEMENTS THAT MAY MODIFY THE WIND RESISTANCE OF THE PLATFORM WITHOUT CONSULTING WITH THE MANUFACTURER.

**MAX. ANCHORAGE FORCES**

Case of:	L (mm)	D <sub>1</sub> +D <sub>2</sub> (mm)	P1 [KN]	P2 [KN]	R1 [KN]	R2 [KN]
Anchor. 750 mm [29.5 in]	840 [33.1 in]	530 [20.8 in]	8,61	-4,33	2,72	1,37
Anchor. 1000 mm [39.4 in]	1.080 [42.5 in]	695 [27.3 in]				
Anchor. 1200 mm [47.3 in]	1.270 [50.0 in]	800 [31.5 in]				
Anchor. 1500 mm [59 in]	1.370 [53.9 in]	850 [33.4 in]				
Anchor. 1800 mm [70.8 in]	1.660 [65.3 in]	1.000 [39.1 in]				

**ATTENTION:**

BE SURE OF THE STRENGTH OF SUPPORT STRUCTURE TO WITHSTAND THE MAXIMUM TRANSMITTED LOADS. IN CASE OF INSTALLING AN ANCHOR IN A DIFFERENT PROVISION, CONSULT THE MANUFACTURER.

### 4) Recommended anchorage system.

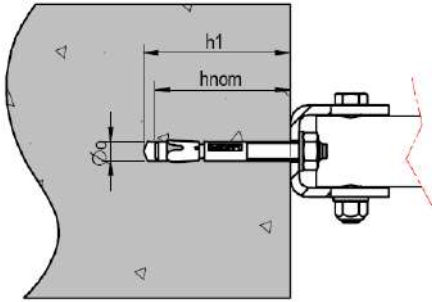

RECOMENDED ANCHOR: HSA-K M12X120 (or SIMILAR)		
$\phi_o$	Drilling diameter	12 mm [15/32 in]
$h_1$	Drilling depth	95 mm [3 47/64 in]
$h_{nom}$	Minimum installation depth	80 mm [3 9/64 in]
L	Anchor length	120 mm [4 23/32 in]
$T_{ins}$	Torque	50 N·m [36 lb·ft]

### OTHER ANCHORING POSSIBILITIES

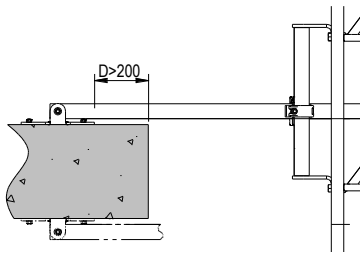

TOP / BOTTOM TIE

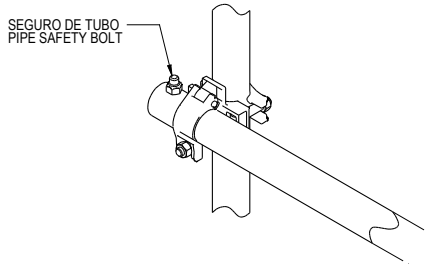

TO VERTICAL TUBE / SCAFFOLDING

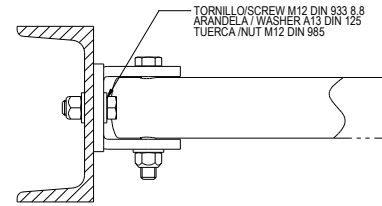

BOLTED JOINT

### 5) Interference checkup.

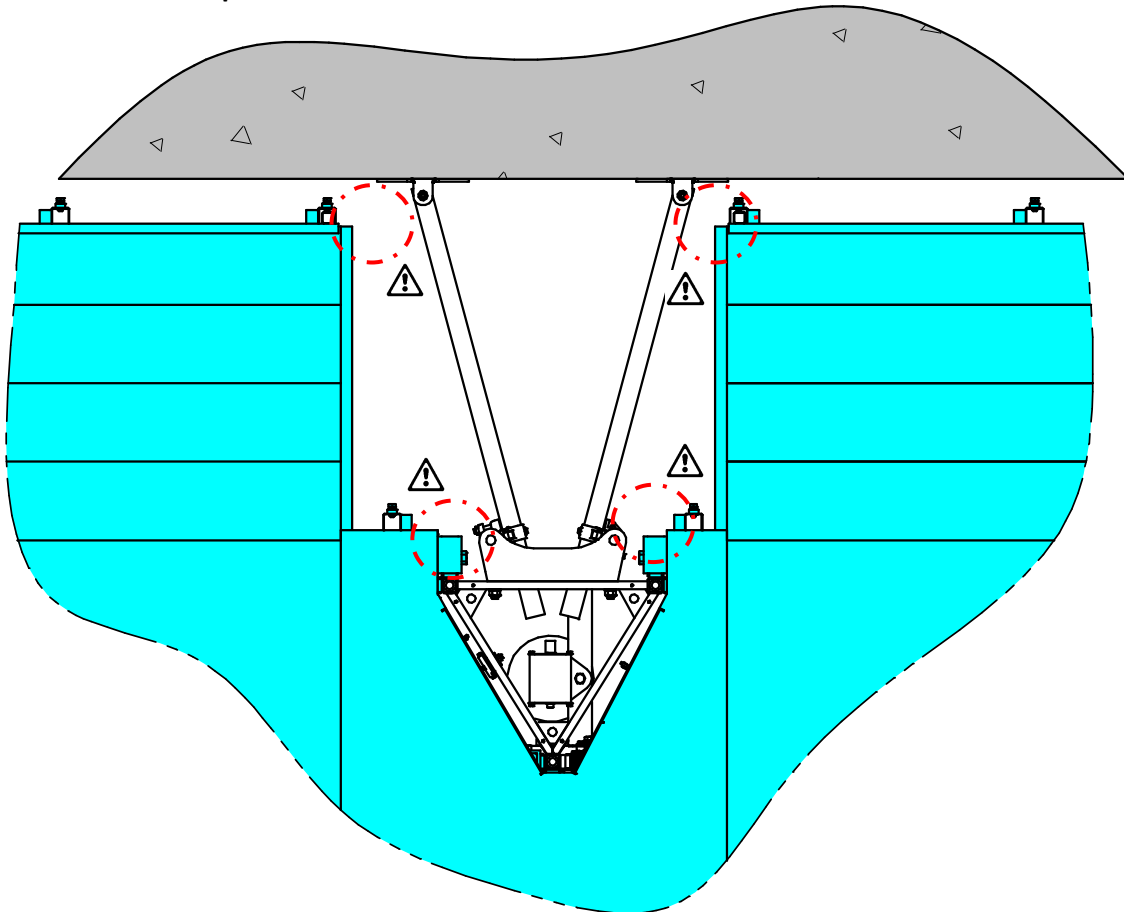

**ATTENTION:**  
**CHECK 4 POINTS OF POSSIBLE INTERFERENCE INDICATED, BEFORE FITTING TO THE STRUCTURE. MOVE THE ANCHOR ARMS IF NECESSARY.**

• Step 10. Assembly of end track cams and red mast.

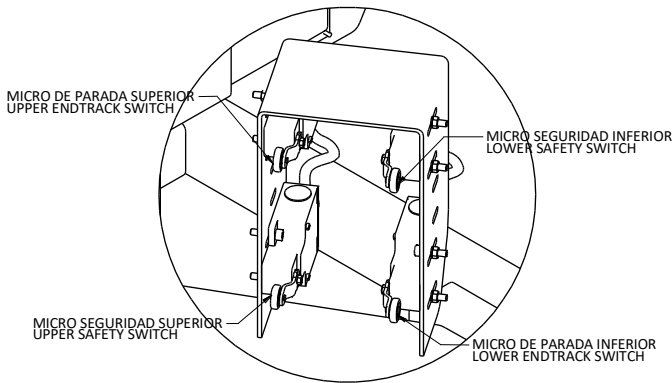

**ENDTRACK SWITCHES ON THE PLATFORM**

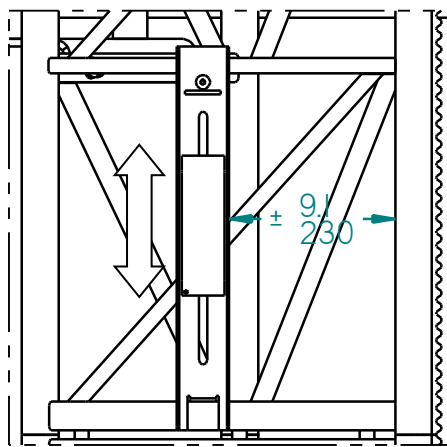

**UPPER ENDTRACK CAM**

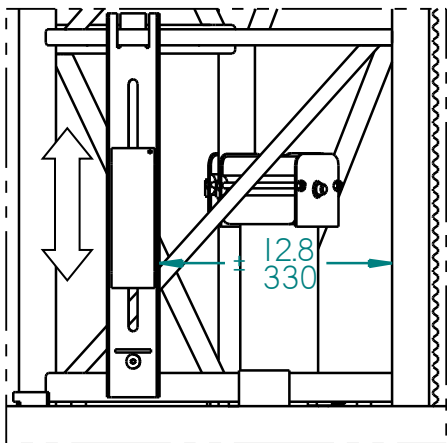

**LOWER ENDTRACK CAM**

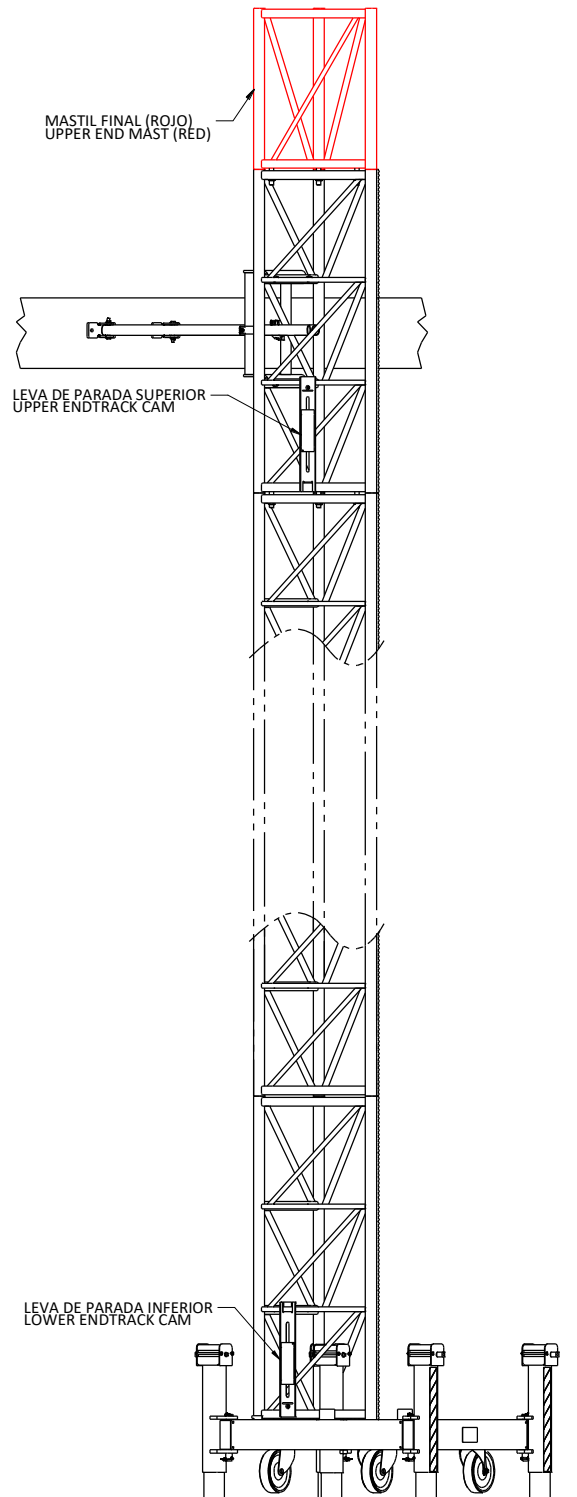

**INSTALLING ENDTRACK CAMS AND RED MAST**



**ATTENTION:**  
**INSTALL UPPER AND LOWER ENDTRACK CAMS, AND CHECK IF THE PLATFORM**  
**STOPS CORRECTLY WHEN REACHING UPPER OR LOWER LIMIT.**  
**FINALLY, INSTALL THE RED MAST WITHOUT RACK.**

• Step 11. Assembly of mast protector.



**ATTENTION:**

**TO COMPLETE THE PLATFORM ASSEMBLY, THE MAST PROTECTOR WILL BE INSTALLED IN THE MOTOR GROUP, SO AS TO PREVENT CONTACT OF USERS OF PLATFORM WITH MOTIONLESS PARTS OF MAST.**

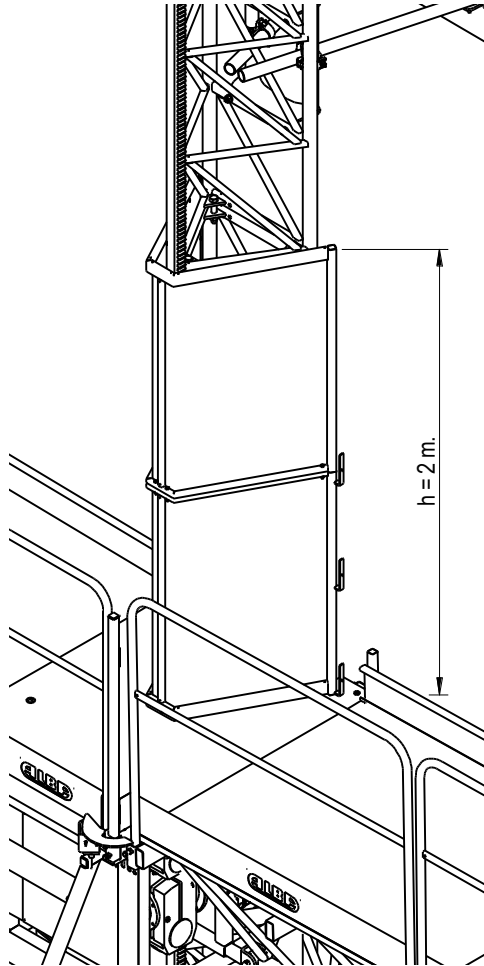

**MAST PROTECTOR**

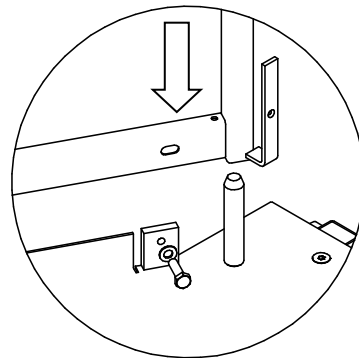
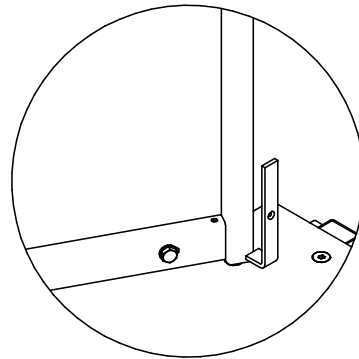

**FITTING MAST PROTECTION**

• Step 12. Filling MCWP handover certificate



**IMPORTANT:**

**ONCE THE PLATFORM IS INSTALLED, AND BEFORE COMMISSIONING TO PERSON RESPONSIBLE ON SITE, PLEASE FILL THE MCWP HANDOVER CERTIFICATE, WHERE INSTALLATION PARTICULAR CHARACTERISTICS ARE DEFINED.**

**CONSULT THE LOAD DIAGRAM TO DEFINE THE PAYLOAD CAPACITY DEPENDING ON CONFIGURATION LENGTH CHOSEN. IF INSTALLING SPECIAL CONFIGURATION, CONSULT THE MANUFACTURER.**

**SEE A MCWP HANDOVER CERTIFICATE EXAMPLE AT THE END OF THE MANUAL.**

## 2.4. Dismantling the platform

For disassembly of the platform will do the reverse described above, with special care on the tasks with risk of people falling from the platform.

Step 1. Dismantling mast and anchors.

Remove first the red mast and then the column of masts and anchorages.



**IMPORTANT:**

**i MOUNT/DISMANTLE SCREWS AND MAST AT THE SAME TIME!  
NEVER RAISE THE PLATFORM OVER A MAST WITHOUT SCREWS  
OTHERWISE, THERE IS A HIGH PROBABILITY OF ACCIDENT!**



**ATTENTION:**

**SPECIAL ATTENTION AT THE TIME OF RELEASE THE LAST ANCHOR  
BEFORE GROUND LEVEL. MAKE SURE THE CORRECT POSITION OF  
THE STABILIZERS AND SUPPORT JACKS.  
CASE OF SINGLE MAST, REMOVE SEVERAL PLATFORM MODULES  
BEFORE STARTING MAST AND ANCHORAGE DISASSEMBLY.**



Step 2. Dismantling electrical equipment and cable system.

Once the lower limit is reached, disconnect power source and subsequently release the connector of the control panel groups and. Collect and store the cable into the holder.

Step 3. Dismantling the platform.

Disassemble the modules of platform, extensions and handrails in reverse mode to the previously described process.

Step 4. Dismantling base groups

Support the wheels of the machine on the ground acting on jacks of stabilizers, and let it rest. When the base group is free to move, you can move on the ground. Remove the base groups.

### 3. USING THE MACHINE

**ATTENTION:**

THE PLATFORM ONLY CAN BE OPERATED BY PERSONNEL APPOINTED, WHO HAVE BEEN TRAINED IN A SAFE OPERATION OF THE MACHINE AND THE MEASURES TO PREVENT HAZARDS.

#### 3.1. Introduction.

**WARNING:**

EVERY DAY, BEFORE STARTING THE PLATFORM, RESPONSIBLE PERSON ON SITE SHOULD CHECK PROPERLY OPERATION OF MACHINE BASED ON AP. 4.1 DAILY MAINTENANCE AND 3.5. CHECKING PLATFORM OPERATION BEFORE COMMISSIONING, ON THIS USER'S MANUAL

**WARNING:**

BE SURE THAT ALL THE PERSONAL PROTECTIVE EQUIPMENT REQUIRED ON THE PLATFORM IS AVAILABLE BEFORE STARTING THE OPERATION.



**PAY SPECIAL ATTENTION TO THE INTENDED HAZARDS ON THE PLATFORM.**

### 3.2. Use of control panel

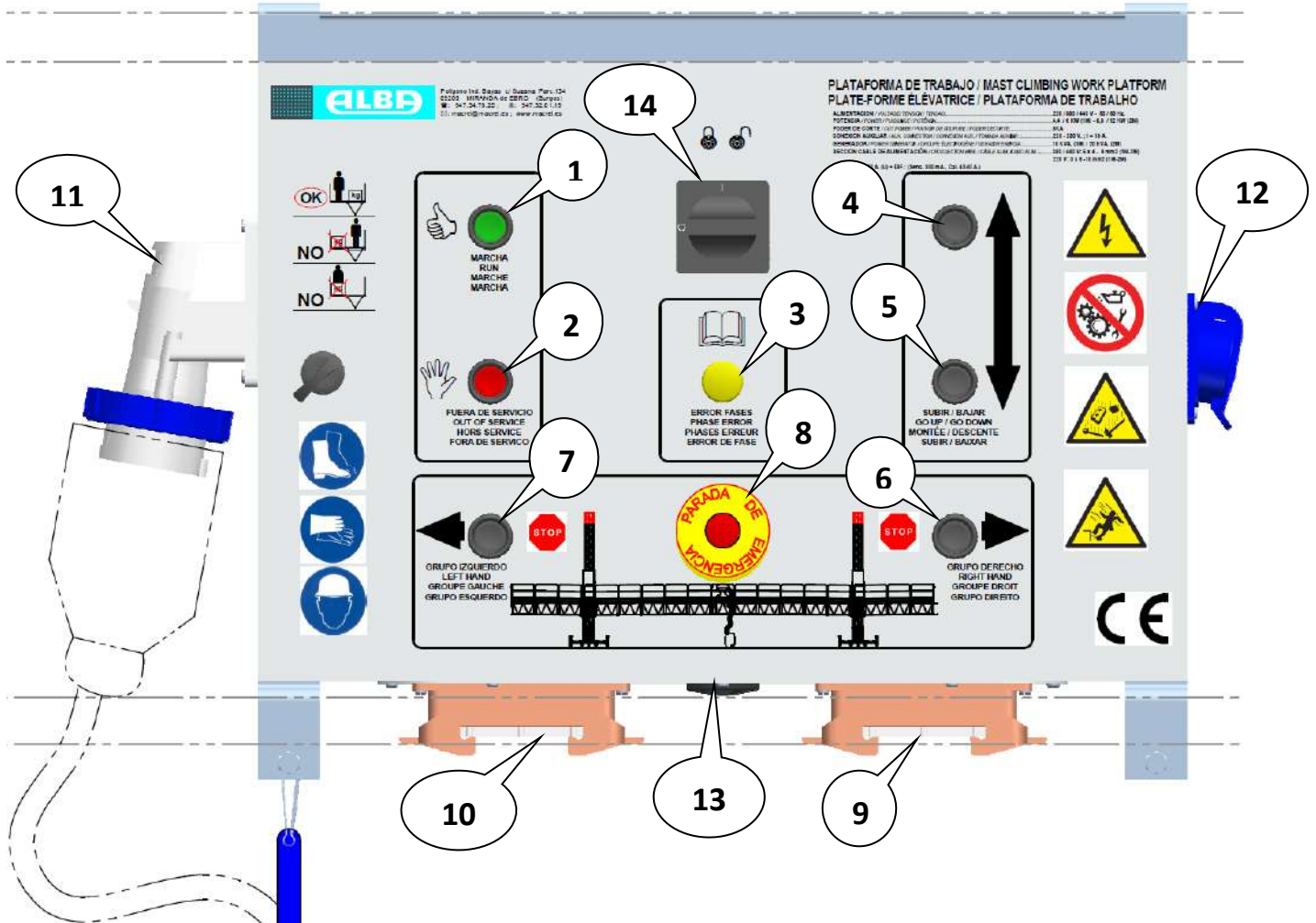

DESCRIPTION OF COMPONENTS OF CONTROL BOARD

1	PUSHBUTTON RUN – REARM: Start electrical service of the machine.
2	PUSHBUTTON STOP / RED LIGHT “OUT OF SERVICE”: Safety device activated
3	YELLOW LIGHT “PHASE ERROR”: Unbalanced, unordered phases, or lack of phase
4	PUSHBUTTON ↑
5	PUSHBUTTON ↓
6	MANUAL LEVELING OF THE PLATFORM – ONLY FOR ASSEMBLY AND SERVICE OPERATION
6	6: STOP RIGHT GROUP
7	7: STOP LEFT GROUP
8	EMERGENCY STOP MUSHROOM
9	MOTOR GROUP CONNECTOR – TWIN MAST
9	9: RIGHT GROUP CONNECTOR
10	10: LEFT GROUP CONNECTOR
10	BRIDGE CONNECTOR – SINGLE MAST
11	ELECTRICAL SUPPLY CONNECTOR (4x) for electrical hose
12	AUX. ELECTRICAL 2X PLUG 120 V – 13 A. Self-Test GFCI Receptacle
13	HORN
14	MAIN OFF- ON SWITCH



**ATTENTION:**  
 USE MANUAL LEVELING BUTTONS ONLY IF NECESSARY, BEFORE ADJUSTING POSITION OF AUTOMATIC LEVELING CAMS.  
 ONCE AUTOMATIC LEVELING CAMS ARE ADJUSTED, PLATFORM WILL CORRECT LEVELING ON NORMAL USE WITH NO OPERATOR INTERVENTION.



**ATTENTION:**  
 CASE OF TWIN MAST, CONNECT BOTH RIGHT AND LEFT MOTOR GROUPS TO THE INFERIOR CONNECTORS ON MAIN SWITHBOARD.  
 CASE OF SINGLE MAST, CONNECT MOTOR GROUP IN ONE OF THE SWITCHBOARD CONNECTORS. TO COMPLETE CONNECTION, BRIDGE CONECTOR 086.65 MUST BE CONNECTED.

### 3.3. Emergency stop



**ATTENTION:**  
 THERE'S AN EMERGENCY STOP MUSHROOM ON CONTROL BOARD THAT, IF PUSHED, IT STOPS PLATFORM IMMEDIATELY.



CASE OF PUSHING EMERGENCY STOP, PLATFORM CONTROL CAN'T BE REARMED UNTIL THE MUSHROOM IS RETURNED TO ITS ORIGINAL POSITION.



**IMPORTANT:**  
 CASE OF MISFUNCTIONING OR BREAKDOWN THAT REQUIRES EMERGENCY STOP ACTIVATION, ESPECIALLY IF PERSONAL SAFETY IS AFFECTED, PLATFORM SHOULDN'T BE REARMED UNTIL PLATFORM ON SITE RESPONSIBLE IS WARNED. HE WILL ASSESS THE HAZARD AND SOLVE THE PROBLEM.  
 DON'T KEEP WORKING ON THE PLATFORM WITHOUT DETECTING AND SOLVING THE PROBLEM.

### 3.4. Emergency lowering

Case of failure of electrical supply without restore, manual emergency lowering can be performed by acting on the motor brake manual release levers VERY CAREFULLY. This task should be carried out at short intervals to avoid overheating of centrifugal brakes. The emergency brakes act to limit lowering speed to a maximum of 20% overrated speed.



**WARNING:**  
 EMERGENCY LOWERING OPERATION IS A HAZARDOUS OPERATOIN, SO REMEMBER THAT:

- IT MUST BE PERFORMED BY TRAINED PERSONNEL
- IT SHOULD BE CARRIED OUT ONLY IF STRICTLY NECESSARY
- PLATFORM FLOOR LEVELING MUST BE PRESERVED

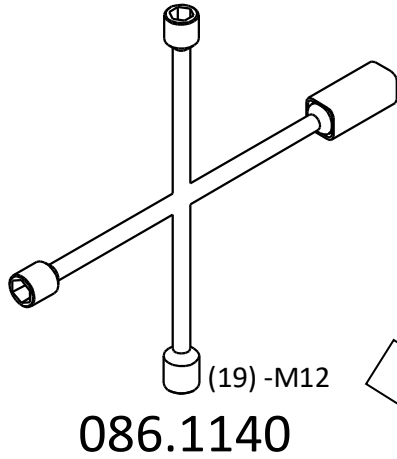

BRAKE RELEASE KEY

EMERGENCY LOWERING

**EMERGENCY LOWERING PROCEDURE:**

- SINGLE MAST PLATFORM  :  
 PERFORM OPERATION VERY CAREFULLY, WITH PERIODICAL BREAKS EACH 6 m. [20 ft], TO AVOID OVERHEATING THE CENTRIFUGAL BRAKES. STOP LOWERING JUST BEFORE TOUCHING THE BASE BUFFERS.

- TWIN MAST PLATFORM  :  
 PERFORM OPERATION VERY CAREFULLY, WITH PERIODICAL BREAKS EACH 6 m [20 ft], TO AVOID OVERHEATING THE CENTRIFUGAL BRAKES.

PERFORM IN A COODINATE WAY ON LEFT AND RIGTH GROUP, SO THE INCLINATION OF THE PLATFORM NOT EXCEED 5°. STOP LOWERING JUST BEFORE TOUCHING THE BASE BUFFERS.

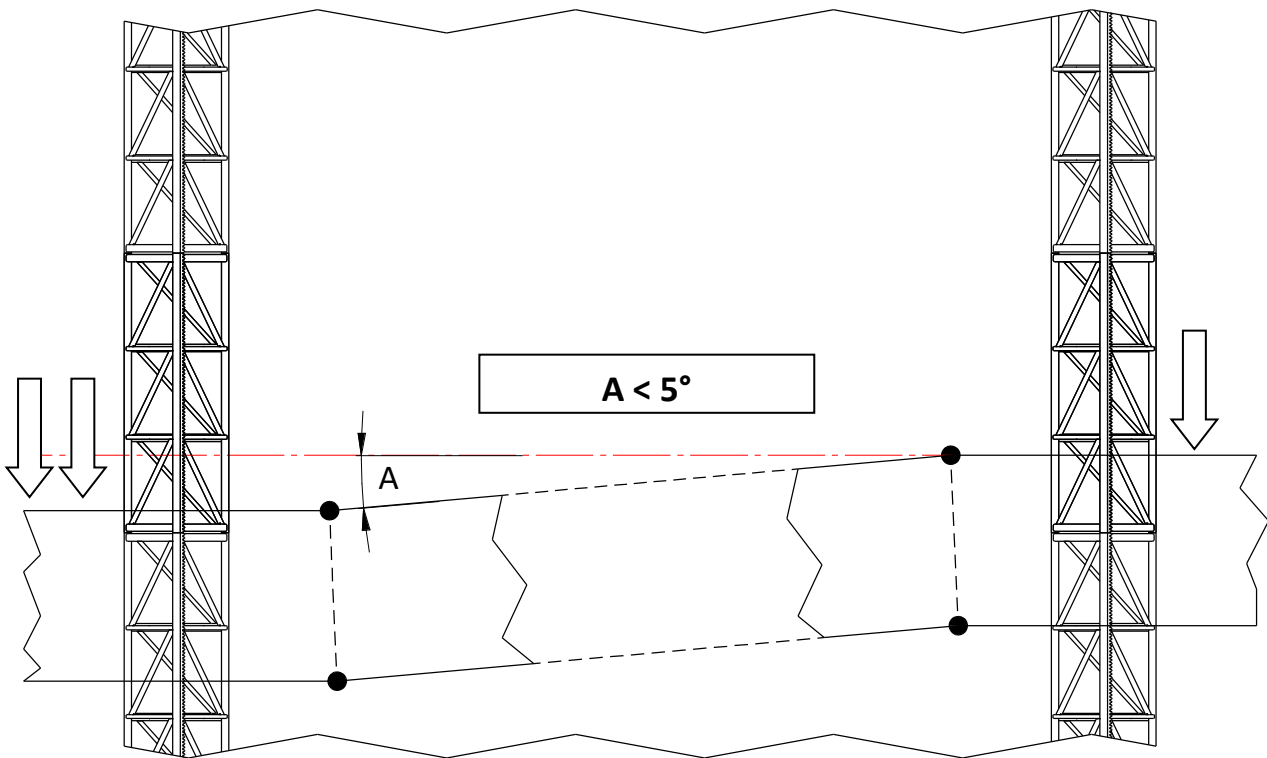

PLATFORM UNLEVELING DURING THE EMERGENCY LOWERING



**IMPORTANT:**

**IF EMERGENCY LOWERING DOESN'T WORK, OR IF IT'S NOT POSSIBLE TO DESCEND THE PLATFORM, PLEASE STAND ON THE PLATFORM AND REQUEST FOR EXTERNAL ASSISTANCE. LEAVE THE PLATFORM COULD CAUSE SERIOUS HAZARD.**

### 3.5. Checking platform operation before commissioning



**IMPORTANT:**

**BEFORE PLATFORM COMMISSIONING, SERVICE RESPONSIBLE WILL CHECK BY MEANS OF VISUAL INSPECTION AND PERFORMING SHORT MOVEMENTS UP AND DOWN, IF IT IS IN COMPLIANCE WITH THE FOLLOWING POINTS:**

- The platform is installed with all operational safety devices:
  - Motor brakes support load properly
  - Superior end track switch stops platform before reaching red mast.
  - Inferior end track switch stops platform before touching base buffers.
  - The door switch works properly.
  - Mast detector (inductive sensor) works properly.
  - Light pilots and indicators on the control panel work properly.
  - Control push buttons are in good condition and work properly.
- There's no interference of hoist and external items, mast, ties, supporting structure, ...
- Automatic levelling system is adjusted, avoiding platform unlevelling over 2°
- There's no accumulation of snow, ice, or materials over the platform or proximity.
- There's no overload and load diagrams are installed and visible on the platform.
- Base supporting jacks are installed properly, levelled and touching the ground.
- There's no outgoing elements on the facade that may interfere with platform travelling.

- Mast anchorages are installed and properly fitted to the facade structure.
- There are no power lines near the platform that endanger people or machine.
- There's a fenced area directly under the platform with barriers and indications to stop by passers accessing and standing there.
- Personnel on the platform have the necessary protective equipment.
- Access points and platform travel paths are sufficiently illuminated.
- All the platform bolts and safety pins are correctly installed.
- Guide rollers are not worn and there's not an excessive gap with mast vertical tubes.
- The platform floor and auxiliary extension floor are firm and solid.
- Motor, pinion and pinion screws are tight, and pinion and rack engagement are correct.



**IMPORTANT:**  
**KEEP CLEAN AND ARRANGED THE WORK PLATFORM ZONE, ACCESS POINTS AND SURROUNDING AREAS.**

### 3.6. Setting on OUT OF SERVICE.



**IMPORTANT:**  
**AT THE END OF DAILY WORK WITH THE PLATFORM, DESCEND TO LOWER POINT AND DISCONNECT ELECTRICAL SUPPLY.**

**FINALLY, DISCONNECT ELECTRICAL CABLE ON BUILDING SITE MAIN POWER SUPPLY. ALSO, WHEN INTENDING PROLONGED PERIODS OF NON-USE.**

### 3.7. Environmental conditions for safe use of machines.

Temperature range for use:	-15°C – 45°C [5°F – 113°F]
Relative humidity:	30 % – 90 %
Max. height for installation:	1000 m [3,280 ft] (**)
Max. wind speed (SERVICE):	55 Km/h [34 mph]
Max. wind speed (ERECTION):	45 Km/h [28 mph]
Max. wind speed (OUT OF SERVICE *):	130 Km/h [80 mph]

(\*) Position OUT OF SERVICE corresponds with hoist at the lowest point and power supply disconnected.

(\*\*) For installation in locations above 1000 m of height., and if the temperature exceeds 45° C, ask the manufacturer for limitations.

ESTIMATIVE WIND SPEED. SCALE BEAUFORT			
	EFFECTS	EFFECTS	VELOCIDAD
0	Calm	Smoke rises vertically	0 -0,8 Km/h.
1	Light air	Smoke drift indicates wind direction	1 -5 Km/h.
2	Light breeze	Wind felt on face; leaves rustle	6 -11 Km/h.
3	Gentle breeze	Leaves, small twigs in constant motion	12 -19 Km/h.
4	Moderate breeze	Leaves and loose paper raised up	20 -28 Km/h.
5	Cool breeze	Small trees begin to sway	29 -38 Km/h.
6	Strong breeze	Large branches of trees in motion	39 -49 Km/h.
7	Moderate gale	Whole trees in motion	50 -61 Km/h.
8	Gale	Twigs and small branches broken off	62 -74 Km/h.
9	Strong gale	Slight structural damage occurs	75 -88 Km/h.
10	Whole gale	Seldom experienced on land	89-102 /h.

**ATTENTION:**

**IF THERE'S NO ANEMOMETER, USE BEAUFORT SCALE TO EVALUATE ESTIMATED WIND SPEED. CASE OF EXCEEDING MAXIMUM ADMISSIBLE SPEED, STOP WORKING IMMEDIATELY AND DESCEND THE PLATFORM AND PUT IN OUT OF SERVICE MODE.**

**3.8. Intended applications.**

- HOUSE BUILDING
- BUILDING FACADES
- REPAIR AND MAINTENANCE OF FACADES
- COVERING FACADES WITH MARBLE, FINISHING BRICKS, ...
- PAINTING FACADES
- INSTALLATION OF THERMAL AND ACOUSTIC INSULATION IN BUILDINGS
- .....

**3.9. Applications and uses forbidden.**

- DON'T use the platform in an explosive atmosphere.
- DON'T use the platform with more load than indicated in diagram for each platform configuration.
- DON'T transport material piled up at the ends of the platform floor, **all loads must be evenly distributed over the surface of the platform.**
- DON'T transport loads overhanging the platform.
- DON'T incline the platform over 2° on horizontal plane.
- DON'T use the platform in adverse weather conditions (See section 3.7)
- DON'T use the platform in unacceptable physical condition, treatment of serious illness, under alcoholic drinks effects, or under stress or mental overload condition.
- DON'T use the machine with other parts than those originals from the manufacturer.
- DON'T work without the necessary personal protection gear. These safety devices will vary upon different conditions, therefore, a qualified person in the requirement of safety and health must evaluate the working conditions and mode of use before starting work.
- DON'T seat or climb over the handrails. The feet of users must always be on the platform floor.
- DON'T access the elevator with inadequate clothing, chains, pendants, rings or loose long hair
- DON'T place any scaffolding or ladder on top of the platform.
- DON'T leave the control panel key to any person other than the one in charge of maintenance or duly authorized.
- DON'T dismantle integrated equipment whose maintenance is only allowed authorized personnel (ej.: electrical motor, brake, gear-reductor).
- DON'T manipulate electrical system without express permission of the manufacturer.
- DON'T use the hoist without a differential switch on the main power supply connection line.
- DON'T use the machine in low light conditions. If necessary, local lighting will be installed in the elevator access points, illuminating the entire platform path.
- DON'T use ceilings or other protective against inclement weather over the platform, which may cause wall effect and can pose a significant increase of forces on the platform and its anchors, not included in the design calculation.



## 4. MAINTENANCE OF THE MACHINE.

**WARNING:**

**BEFORE PERFORMING ANY MAINTENANCE ACTION, TURN THE POWER OFF AND BLOCK VERTICAL MOVEMENT AT LEAST 1.8m [6 ft] HEIGHT UNDER THE PLATFORM. MAINTENANCE TASKS MUST BE PERFORMED WITHOUT LOADS.**

### 4.1. DAILY Maintenance.

The daily maintenance of the machine includes basic visual inspection operations by the person RESPONSIBLE for the machine on site. EVERY DAY, and always before use, a visual inspection of the platform must be carried out in accordance with the following points of attention:

- There's no accumulation of ice, snow or debris inside the platform, or in proximity.
- Stabilizers and support jacks are in good condition and rest on the ground properly.
- There's no mast rack or vertical pipes undue wear.
- All handrails are installed according to user's manual and there's no dangerous gaps.
- The load diagram is installed and visible on the front of the platform.
- The area below the platform is bounded, preventing people from staying below.
- There are no bent or cracked parts (In this case they must be replaced by new ones).
- The wiring and connecting hose are in good condition and properly guided.
- Machine guide rollers are in contact with the faces of mast tubes, and without excessive gaps.
- No overhead lines are present in the proximity, which may pose any hazard for user or machine.
- There are no objects that could come off the building in contact with the platform.
- The load placed on the machine does not exceed the external bodywork of the platform.
- Electric safety devices work properly (Doors, end track microswitches, mast detector...).
- The emergency stop works properly.
- Wall anchors are correct, and tie arms properly fixed to the mast.
- Rack / pinion engagement is correct.
- The control panel and switchboard are clean and dry.
- Every control and lights operate properly.
- The cable holder is in its correct position and the wire is wound inside properly.

Once successfully checked all previous control points with a simple visual inspection and making small movements up and down with the platform, it can be used safely.



## 4.2. PERIODIC Maintenance.



**WARNING:**  
**IN THE CASE OF ELECTRICAL MALFUNCION IN THE HOIST, DO NOT HANDLE ELECTRICAL EQUIPMENT. MAINTENANCE AND INSPECTION ONLY MUST BE PERFORMED BY AUTHORIZED PERSONNEL.**

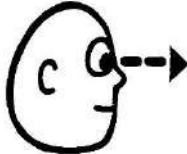
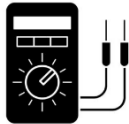

Maintenance of the lift must be performed by the staff responsible for the machine and the results must be recorded in the MAINTENANCE RECORD.

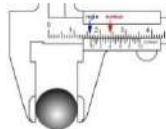
MAINTENANCE TASKS SCHEDULE				
	OPERATION	ELEMENT	TOOL	PERIODICITY
1		<ul style="list-style-type: none"> <li>PLATFORM UNION BOLTS AND SAFETY PINS.</li> <li>PLATFORM FLOOR</li> <li>ENDTRACK CAMS (SUPERIOR AND INFERIOR).</li> <li>MAST SENSOR (CHECK GAP: ±5 mm.).</li> <li>MOTORGEAR OIL LEVEL.</li> <li>DOOR MICROSWITCH</li> <li>MOTORGEAR BOLTS AND NUTS (INSPECTION)</li> <li>CONTROLBOARD LIGHTS AND BUTTONS.</li> <li>MAST TUBES (WEAR, EROSION, WELDING)</li> <li>MAST RACK (INSPECTION)</li> <li>BRAKE RECTIFIER (INSPECTION)</li> <li>ELECTRICAL WIRE (INSPECTION).</li> <li>GUIDE ROLLERS (INSPECTION).</li> <li>ANCHORAGE ARMS AND CLAMPS (INTERF / LOOSENING)</li> <li>BASE BUFFERS (INSPECTION)</li> </ul>	-	40 h. WORK (MONTHLY)
2		<ul style="list-style-type: none"> <li>ELECTRIC TEST FOR MOTOR (Pag.53)</li> </ul>	AMPERIMETER	40 h. WORK (MONTHLY)
3		<ul style="list-style-type: none"> <li>MAST RACK</li> <li>GEAR MOTOR PINION</li> </ul>	LITIUM GREASE	40 h. WORK (MONTHLY)
4		<ul style="list-style-type: none"> <li>MAST SCREWS</li> <li>GUIDE ROLLERS SCREWS.</li> <li>ANCHORAGE TO STRUCTURE SCREWS</li> <li>HANDRAILS SCREWS</li> </ul>	WRENCH	QUARTERLY (4/YEAR)
5		<ul style="list-style-type: none"> <li>CENTRIFUGAL BRAKE TESTING</li> </ul>	QUARTERLY	QUARTERLY
6		<ul style="list-style-type: none"> <li>GUIDE ROLLER DIMENSION.</li> <li>RACK DIMENSIONS</li> <li>GEARMOTOR PINION STRING</li> <li>MOTORBRAKE</li> </ul>	CALIBER CALIBER MICROMETER GAUGES	SEMESTERLY (2 TIMES/YEAR)
7	<p><b>GENERAL REV.</b>  <small>(AFTER DISMANTLING OR PROLONGED NON-USE PERIOD)</small></p>	<ol style="list-style-type: none"> <li>1. DEFORMATION OR DAMAGE ON MASTS, ANCHOR, DOORS, HANDRAILS, FLOOR, ...</li> <li>2. GEARMOTOR INSPECTION (SEE MAINT. INSTRUCTIONS: MOTORBRAKE AND GEARMOTOR)</li> </ol>		

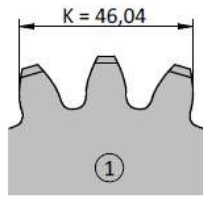
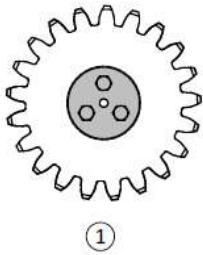
**MECHANICAL CHECKING DIAGRAM**

①

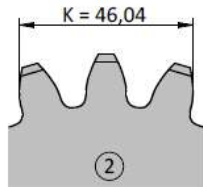
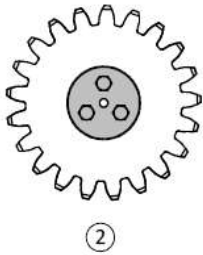

②

**CONTROL MEASURES K [mm/in]**

	Nom.	Min.
PINION Z22	46,04 [1 13/16]	43,5 [1 45/64]

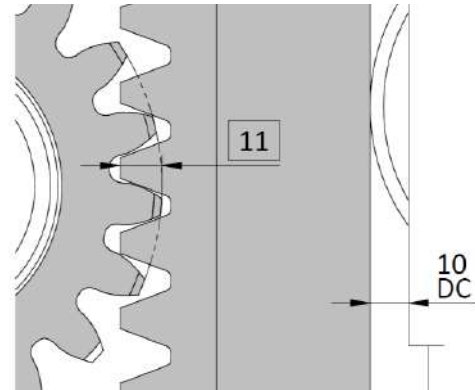
**OVERLAP □ [mm/in]**

	Nom.	Min.
□	11 [27/64]	8 [5/16]
DC	10 [25/64]	5 [3/16]

**CONTROL MEASURES □ [mm/in]**

	Nom.	Min.
□ A	4,6 [11/64]	3,4 [1/8]
□ B	29,6 [1 5/32]	28,4 [1 7/64]

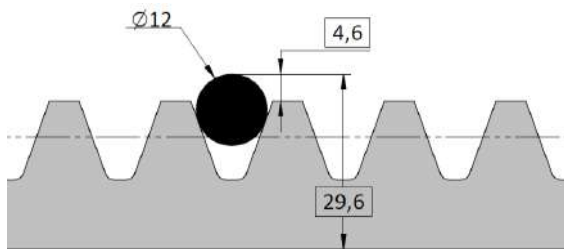
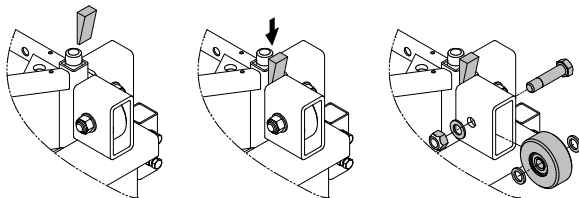
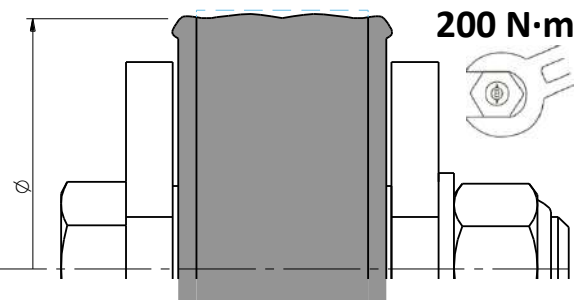
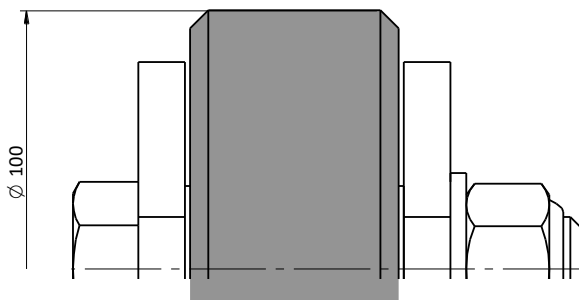
**CHECKING RACK AND PINION WEAR**

**MEDIDAS DE CONTROL [mm/in]**

	Nom.	Min.
∅	∅100 [3 59/64]	∅97 [3 13/16]

**CHECKING AND SUSTITUTION OF MAST GUIDE ROLLERS**

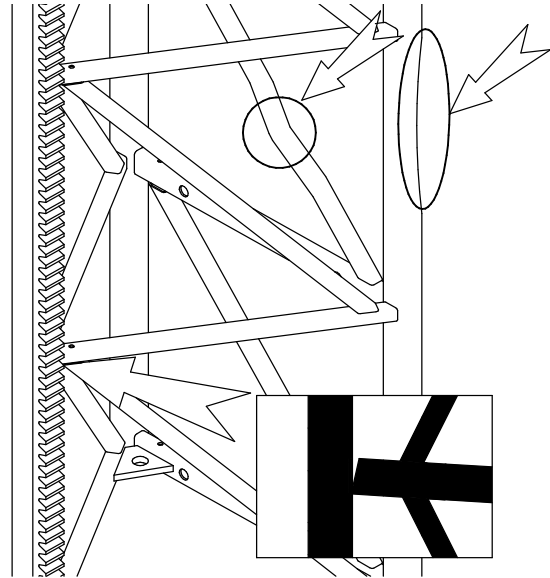
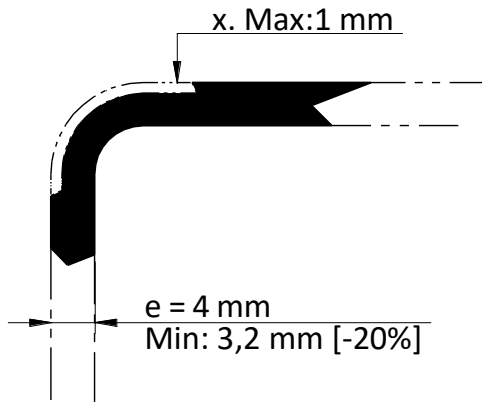
**IMPORTANT:**  
CHECK IF ROLLER WEAR IS THE SAME THROUGHOUT THE ENTIRE CIRCUMFERENCE OF CONTACT.

**CHECKING MAST FRAME AND VERTICAL TUBES WEAR**

**ATTENTION:**  
**CHECK FOR POSSIBLE DAMAGE AND EXCESSIVE WEAR OF THE MAST TUBES BEFORE ASSEMBLY AND LATER, WITH THE PERIODICITY INDICATED.**

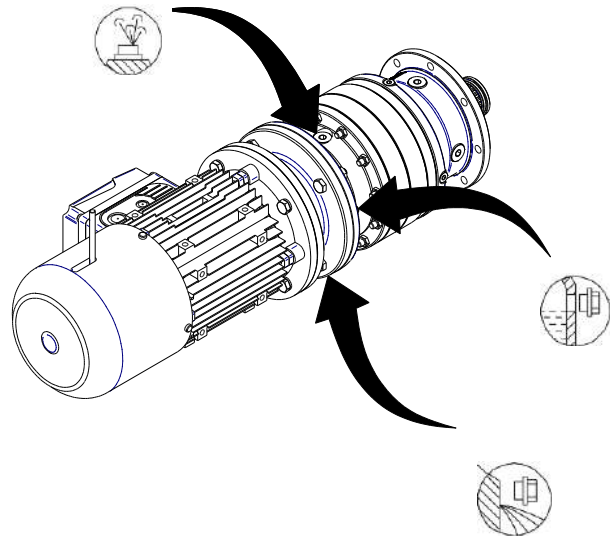
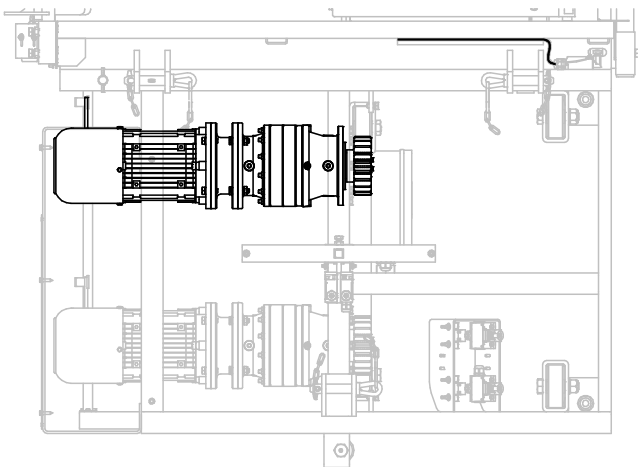
**GEARBOR MAINTENANCE**

Properties			Method	Shell Omala S4 GXV 220
Kinematic Viscosity	@40°C	mm <sup>2</sup> /s	ASTM D445	220
Kinematic Viscosity	@100°C	mm <sup>2</sup> /s	ASTM D445	30
Viscosity Index			ASTM D2270	171
Flash Point (COC)		°C minimum	ASTM D92	240
Pour Point		°C	ASTM D97	-42
Density	@15°C	kg/m <sup>3</sup>	ASTM D4052	864
Four Ball EP Weld load		kg minimum	ASTM D2783	250
FZG Load Carrying Test		failure load stage minimum	A/8, 3/90	14

**GEARBOX OIL CHARACTERISTICS**



**IMPORTANT:**  
**GEARBOXES ARE INSTALLED COMPLETE WITH SYNTHETIC 220 OIL FOR "LIFE LUBRICATION", IN THE ABSENCE OF EXTERNAL CONTAMINATION.**  
**IF IT IS NECESSARY TO REPLACE THE OIL, REPLACE IT WITH THE OIL WITH THE VISCOSITY GRADE INDICATED IN THE TABLE.**



**IMPORTANT:**  
**GEARBOX LUBRICATION OIL IS PREPARED TO USE WITH AMBIENT TEMPERATURE RANGE 0°C<T< 40 °C [32°F–104°F], WITH PEAKS TILL -20°C<T< 50 °C. [-4°F–122°F].**

**AUTOMATIC GREASING SYSTEM (OPTION)**

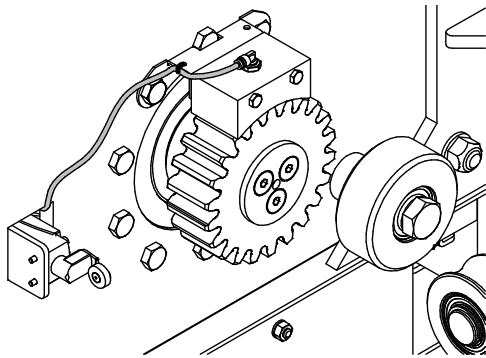
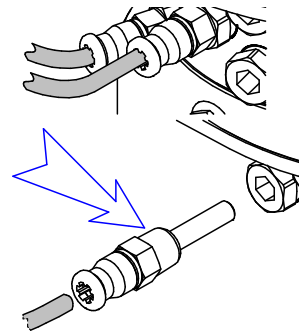

**GREASING POINTS POSITION**

**GREASE DISTRIBUTION UNIT**
**GREASING SYSTEM TECHNICAL FEATURES**

Grease TYPE	Lithium grease	
Types of grease allowed:	NLGI	ASTM
Very soft	0	355 – 385
Medium soft	1	310 – 340
Medium (Recommended)	2	265 - 295
Tank capacity:	0,5 l.	
Lubrication speed:	2x12 gr/h.	
Tank life:	~ 70 h. (Platform working)	



- CONTROL LOCKED (PRESS ↑↓ TO UNLOCK)
- YELLOW – GREASING PUMP WORKING
- RED – GREASING MOTOR BLOCKED
- RED – MIN. GREASE TANK LEVEL
- RED – VOLTAGE UNDER MIN. LEVEL
- CANCEL ALARM / GREASING EXTRA CYCLE
- INCREASE OR REDUCE GREAS FREQ. /CYCLE.  
SIMULTANEUN PRESS. – LOCK CONTROL

**GREASING UNIT CONTROL CONSOLE**

**IMPORTANT:**

**DO NOT MANIUPULATE GREASING CYCLES. CHECK PERIODICALLY AVAILABLE GREASE LEVEL. CASE OF MALFUNCTIONING OF THE PUMP, PLEASE CONSULT THE MANUFACTURER.**

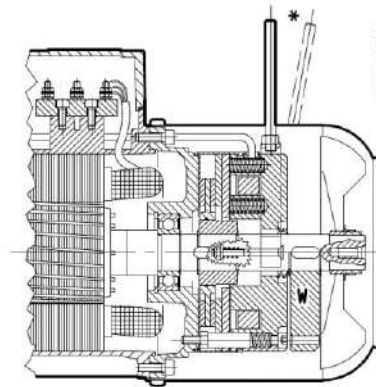
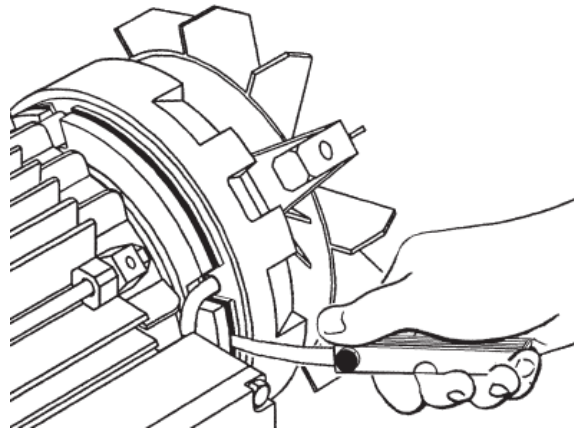
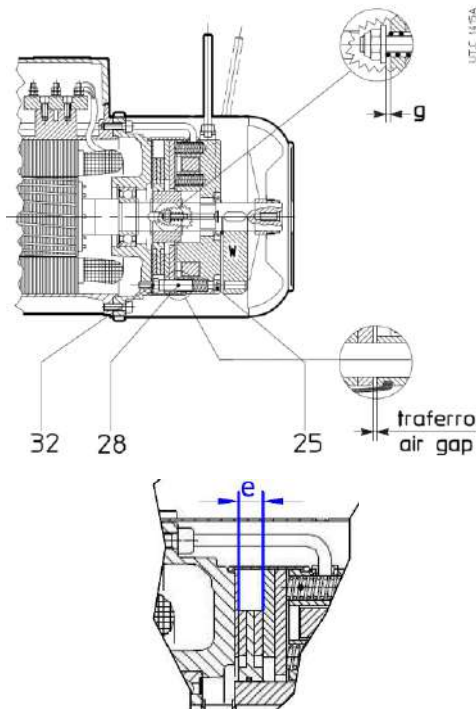
**INSTRUCTION FOR MAINTENANCE OF ELECTRIC MOTOR-BRAKE**

**MOTOR-BRAKE WITH D.C. BRAKE AND MANUAL RELEASING LEVER**

**CONTROL MEASURES [mm/in]**

	Nom.	Max.	Min.
Traferro (air gap)	-	0,45 [0.017]	0,3 [0.011]
Brake disk thickness (e)	-	-	7 [0.275]
Lever backlash (g)	0,6 [0.023]	-	-

**BRAKE PERIODICAL MAINTENANCE**

**IMPORTANT:**  
**EXCESSIVE AIR-GAP, SUPERIOR TO MAX. VALUE, COULD PRODUCE BRAKE TORQUE DECREASING. CHECK PERIODICALLY AIR-GAP AND ALSO BRAKE DISK THICKNESS, ACCORDING TO TABLE ABOVE.**

**BRAKE ADJUSTMENT PROCEDURE:**

1. Release nuts **Nº32**, located 3 positions separated 120°
2. Screw fastening screws **Nº25**. [Case of flywheel, act through the proper holes], in order to reach minimum airgap, measuring by a thickness gauge in 3 positions at 120° near the guiding bushes **Nº28**.
3. Tighten nuts **Nº32** keeping in position fastening screws **Nº25**.
4. Verify the obtained air-gap value and compare with values in table above.



**IMPORTANT:**

AFTER SEVERAL AIR-GAP ADJUSTMENTS, PLEASE VERIFY THAT BRAKE DISK THICKNESS (e) IS NOT LOWER THAN MINIMUM VALUE STATED IN TABLE. IF NECESSARY, REPLACE THE BRAKE DISK.



**IMPORTANT:**

AFTER BRAKE ADJUSTMENT, CHECK RELEASE IF LEVER BAKCLASH (g) ALLOWS MANUAL BRAKE RELEASING PROPERLY. IF NECESSARY, AMEND (g) VALUE ACCORDING TO TABLE ABOVE.

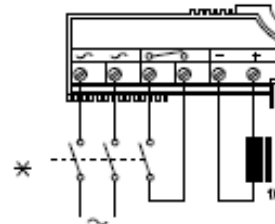
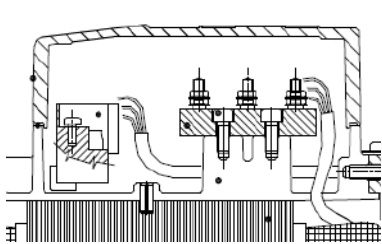

**D.C. BRAKE POWER SUPPLY RECTIFIER**

BRAKE RECTIFIER CHECKING TABLE

a) Input voltage Vac	( ~ . ~ )	230 Vac
b) Output voltage Vdc	( - . + )	75 – 105 Vdc
c) Coil resistance value (*)	( - . + )	±250 Ω

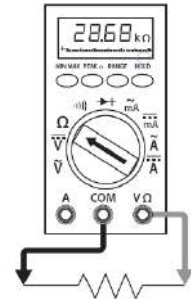
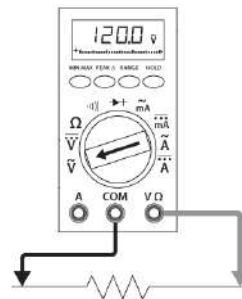
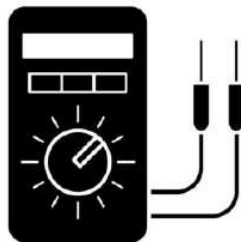

a) ~.~ ; b) - . +

c) Ω

**BRAKE RECTIFIER COMPROBATION TABLE**



**IMPORTANT:**

CHECK INPUT VOLTAGE Vac AND OUTPUT VOLTAGE Vdc WITH HOIST WORKING, IN ORDER TO VERIFY RECTIFIER PERFORMANCE.

¡¡ ATENTION: ELECTRICAL CONTACT HAZARD!!



**IMPORTANT (\*):**

IN ORDER TO CHECK BRAKE COIL, RELEASE RECTIFIER VOLTAGE OUTPUT WIRES (+, -) AND VERIFY COIL RESISTANCE VALUES IN TABLE ABOVE, ACCORDING TO POINT c) INSTRUCTION. REPLACE BRAKE COIL IF NECESSARY.

**CONSUMPTION TEST FOR ELECTRIC MOTOR**



**IMPORTANT:**  
**THE TEST MUST BE PERFORMED BY AN AUTHORIZED TECHNICAL PERSON, SPECIALLY TRAINED TO HANDLE ELECTRICAL EQUIPMENT.**  
**ATTENTION:**  
**¡¡ ELECTRIC SHOCK HAZARD!!**



1. Locate maximum load on the platform, according to instructions in user's manual.
2. Check and adjust values for thermal relays RT1,...,RT4: ..... **6,5A.**
3. Release the motor terminal box cover.

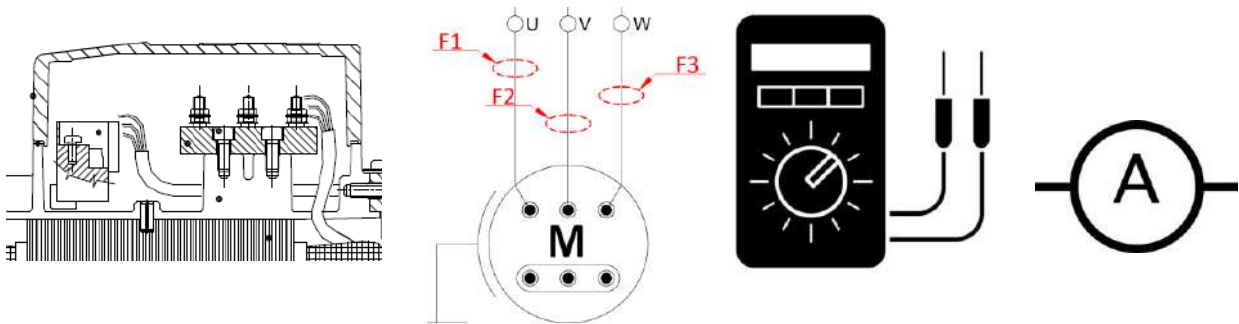

4. Check the amperage in all phases F1, F2, F3 [Amp.] on both motors long enough to stabilize electrical current consumption values. For each drive unit, must be met:

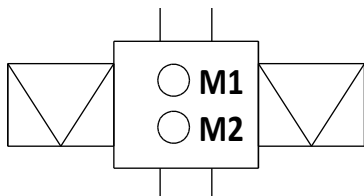

TEST OK CONDITION		
Current consumption M1	Max.	Difference M1 – M2
Current consumption M2	6,5 A	< 1,5 A

5. Remove the load of the platform and reassembly motor terminal box cover.



**IMPORTANT:**  
**IN THE CASE OF CONDITIONS OF THE TABLE ABOVE ARE NOT MET, THE PLATFORM MUST BE STOPPED THE PLATFORM AND THE GEARMOTORS MUST BE CHECKED. CASE OF DOUBTH, CONSULT THE MANUFACTURER.**



**IMPORTANT:**  
**CASE OF RT1,...,RT4 TRIP, M1 - M2 MOTOR CURRENT CONSUMPTION AND MOTOR ELECTROMAGNETIC BRAKE MUST BE CHECKED.**

## MOTOR BRAKE AND GEARMOTOR VERIFICATION TEST



### IMPORTANT:

**AFTER EACH DISASSEMBLY OR NON-USE PERIOD AND BEFORE THE MACHINE SERVICE START, VERIFY THE GEARMOTOR, CENTRIFUGAL BRAKE AND MOTOR BRAKE**

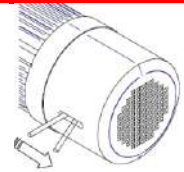

1. The base will settle over the buffers, and it will have an additional mast allowing some movement.
2. Run a test without load and then run it with the appropriate test load (PEC 120: **2000Kg [4,400lb]**)
3. Make small up and down movements verifying non-slip stops.
4. Manually free the brake lever alternatively, verifying a single brake can hold the platform without slipping.
5. **Check the noise and vibrations absence while platform is moving.**

Rossi		a company of the Habaiss group www.rossi-group.com		IEC 60334-1 IE1 CE made in Italy	
MOT. 3~ N	06202/11 01/11	IP 55	AMB. 40°C IC 411		
HBZ 80B4	B5	kg 9.2	I.C.L. F S 1 CONT.		
Brake	Nm	V~/ Hz	A	RM1	V=
BZ04	15	110+480/50+60	0,11		103
Δ V	Y	Hz	A	kW	min <sup>-1</sup> cos φ
230 / 400		50	3.3 / 1.9	0.75	1400 0.72
265 / 460		60	3.3 / 1.9	0.75 SF1.15	1690 0,68
50Hz IE1 74,7(100%) 74,2(75%) 70,5(50%)					
60Hz NEMA NOM.EFF. 78,5% 1HP DES.C. CODE K					

### MOTOR PLATE EXAMPLE TO SPARE PART REQUESTING GEARMOTOR – ELECTRIC MOTOR SUBSTITUTION

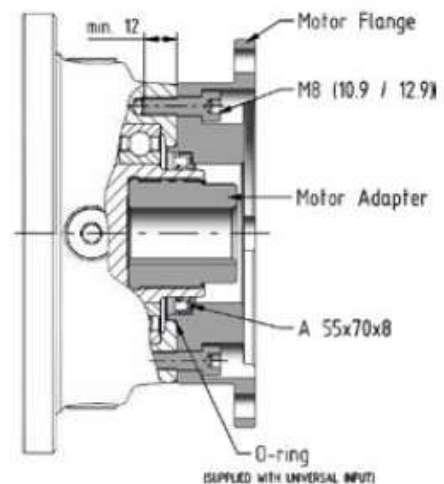
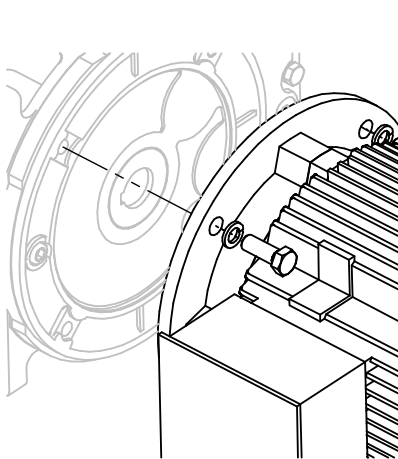

1. Clean motor and gearbox surface to be fitting thoroughly.
2. Install the pinion spacer in the motor axle with locking adhesive.
3. Fit motor flange and gearbox with fixing screws and washers.

### PREVENTIVE MAINTENANCE OF MOTOR AND ELECTRIC BRAKE:

- Keep external surfaces free from oil, dust and machining residuals.
- Keep free all air cooling circuits (housing, air input).
- Check that electric connections are fitted properly.
- Check the correct tightness of the motor and see that there are no leaks in the seals.
- Check that motor run is free from vibrations and anomalous noises.

**IMPORTANT:**

TO ORDER SPARE PARTS FOR THE MOTOR OR ELECTRIC BRAKE, IT IS NECESSARY TO REFER TO THE MOTOR PLATE INFORMATION. THAT WAY, SPARE PART SUPPLY ERRORS ARE AVOIDED.

**INFORMATION:**

IF YOU REQUIRE TECHNICAL ASSISTANCE FOR GEARMOTOR, YOU CAN CONTACT THE MANUFACTURER, OR THE SERVICE MOTOR MANUFACTURER IN EACH COUNTRY. SEE CONTACT POINTS: <http://www.rossi-group.com>



### 4.3. Instructions for troubleshooting.

#### GEARMOTOR

Problem	Probable cause	Solution
Motor doesn't work	Supply line fault. Motor box connection fault Brake doesn't work. Motor internal fault	Check 3-phase electric supply. Check motor connection. Check brake s/section. 4.2 Consult the manufacturer
Motor can't raise rated load	Motor connection problem Insufficient voltage supply Supply voltage drop	Check motor connection. Check the supply line. Check supply cross section wire
Motor overheats	Motor connection error Motor locked. Voltage supply error Fan covers obstructed. Insufficient ventilation air flow Brake doesn't work	Check motor connection. Check brake s/section. 4.2 Check the supply line. Release air passage to the fan. Check for obstacles to ventilation. Check brake s/section. 4.2
Excessive current consumption	Brake locked. Motor coil damage Gearbox fault	Check brake s/section. 4.2 Ask the manufacturer. Check motor s/page 53
Motor brake doesn't release	Brake connection fault Rectifier damaged Excessive brake airgap Brake coil damaged	Check motor connections. Check the rectifier s/section. 4.2 Check air-gap s/section. 4.2 Check brake coil s/section. 4.2
Brake doesn't hold the load	Excessive brake airgap Brake coil damaged Excessive brake disk wear	Check brake coil s/section. 4.2 Consult the manufacturer. Replace brake disk
Excessive brake noise	Excessive airgap	Check brake s/section. 4.2
Gearmotor sounds abnormally	Lack of oil on the gearbox. Gearbox bearing failure	Check oil levels and oil leaks. Consult the manufacturer

#### GENERAL

Problem	Probable cause	Solution
The control board doesn't work. (NONE OF PILOT LIGHTS ARE ON)	Emergency stop activated. Lack of electrical supply Connection error	Check emergency stop. Check electrical supply. Check single drive unit connector
Yellow light PHASE ERROR is active	Phase error /unbalanced phase	Change supply phase connection
Platform control panel doesn't rearm. (OUT OF SERVICE RED LIGHT ON)	Safety device activated	Check safety devices: - Upper limit microswitch (FCSS) - Lower limit microswitch (FCSB) - Mast detector (IND) - Anchorage safety system (FCSA+FCSE) - Levelling safety microswitch (FCNIVS) - Door safety microswitch (FCP)
Platform doesn't move (NONE OF PILOT LIGHTS ARE ON)	Motor thermal protection activated. Excessive adjustment of levelling system	Check thermal relays RT1...,RT4. Check levelling microswitch (FCNIV)
Platform moves doing abnormal noise and doesn't do it softly	Guide rollers or bears are damaged. Lack of grease on pinion. Lack of grease on rack	Check guide rollers and bears. Grease rack-pinion engagement
Platform slides down when loads on it	Brake damage or failure Overload	Check brake s/section 4.2. Remove overload
Electrical motor starts difficulty	Brake motor doesn't work. Overload Insufficient voltage supply	Check brake s/section. 4.2 Check load and positioning on the platform. Check electrical supply voltage
Protection MT1 or MT2 failure	Problem with voltage transformer or control circuit.	MT1: Replace control transformer. MT2: Check electrical control circuit
Platform stops suddenly	Electrical supply failure Safety switch failure or misadjustment	Check electrical connection. Check safety microswitches
Platform vibrates abnormally	Screws or rollers untightened. Rack-pinion engagement problem. Lack of lubrication Excessive wear in mast vertical tubes	Check guide rollers adjustment. Check rack-pinion gear. Lubricate rack and pinion. Check mast for tube wear

Platform moves with interruptions	Electrical wiring damaged Safety switch failure	Check wiring status. Check safety switches
The platform can't lift the load	Inadequate wire cross-section Motor brake failure Voltage supply failure on site Inadequate generator power supply (KVA)	Check communication cable. Check / replace motor brake. Check voltage supply. Check generator supply power (KVA)

**ATTENTION:**  
**CHECK IF HOIST IS CONNECTED TO A POWER SUPPLY EQUIPED WITH DIFFERENTIAL PROTECTION 300mA.**

**4.4. Maintenance record.**

According to the procedure specified in the user's manual, the person responsible for maintenance of the hoist should fill this table according to the frequency indicated, for the record of scheduled tasks.

Nb	DATE	MAINTENANCE TASK	NAME	SIGNATURE
1				
2				
3				
4				
5				
6				
7				
8				
9				
10				
11				
12				
13				
14				
15				
16				
17				
18				
19				
20				
21				
22				
23				
24				
25				
26				
27				
28				
29				
30				
31				
32				
33				
34				
35				

Nb	DATE	MAINTENANCE TASK	NAME	SIGNATURE
36				
37				
38				
39				
40				
41				
42				
43				
44				
45				
46				
47				
48				
49				
50				
51				
52				
53				
54				
55				
56				
57				
58				
59				
60				
61				
62				
63				
64				
65				
66				
67				
68				
69				
70				
71				
72				
73				
74				
75				
76				
77				
78				
79				
80				
81				
82				
83				
84				
85				

**4.5. Fault record.**

TYPE OF FAILURE: .....

Cause: .....

Reparations performed: .....

.....

.....

		PARTS TO CHANGE			
Code	Denomination	Quantity	Code	Denomination	Quantity

ALBA authorized technical person

User

.....

.....

Place .....

Date.....

TYPE OF FAILURE: .....

Cause: .....

Reparations performed: .....

.....

.....

		PARTS TO CHANGE			
Code	Denomination	Quantity	Code	Denomination	Quantity

ALBA authorized technical person

User

.....

.....

Place .....

Date.....

TYPE OF FAILURE: .....

Cause: .....

Reparations performed: .....

.....

.....

		PARTS TO CHANGE			
Code	Denomination	Quantity	Code	Denomination	Quantity

ALBA authorized technical person

User

.....

Place ..... Date.....

TYPE OF FAILURE: .....

Cause: .....

Reparations performed: .....

.....

.....

		PARTS TO CHANGE			
Code	Denomination	Quantity	Code	Denomination	Quantity

ALBA authorized technical person

User

.....

Place ..... Date.....

TYPE OF FAILURE: .....

Cause: .....

Reparations performed: .....

.....

.....

		PARTS TO CHANGE			
Code	Denomination	Quantity	Code	Denomination	Quantity

ALBA authorized technical person

User

.....

Place ..... Date.....

TYPE OF FAILURE: .....

Cause: .....

Reparations performed: .....

.....

.....

		PARTS TO CHANGE			
Code	Denomination	Quantity	Code	Denomination	Quantity

ALBA authorized technical person

User

.....

Place ..... Date.....

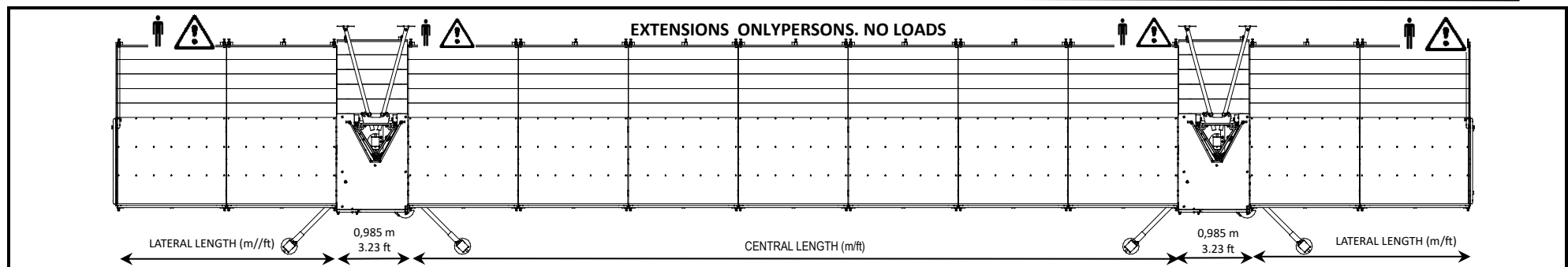

### PEC 120 TWIN MAST WORK PLATFORM

Lateral length (m/ft)	Modules	Maximum load	Central platform (m/ft)	Modules	Maximum load	LOADING EXAMPLES									
						Total length (m/ft)	Maximum load								
1,5 / 4.92	1 X 1,5 m	750 Kg / 1,650 lb	6 / 19.68	4 X 1,5 m	2500 / 5,511 lb	10,97 / 35.99	4000 Kg / 8,820 lb								
			6,82 / 22.37	4 X 1,5 m + 1 X 0,82 m	2400 / 5,290 lb	11,79 / 38.68	3900 Kg / 8,600 lb								
			7,50 / 24.6	5 X 1,5 m	2300 / 5,070 lb	12,47 / 40.91	3800 Kg / 8,375 lb								
			8,32 / 27.29	5 X 1,5 m + 1 X 0,82 m	2200 / 4,850 lb	13,29 / 43.60	3700 Kg / 8,160 lb								
2,32 / 7.61	1 X 1,5 m + 1 X 0,82 m	725 Kg / 1,560 lb	9 / 29.52	6 X 1,5 m	2150 / 4,740 lb	15,61 / 51.21	3600 Kg / 7,935 lb								
			9,82 / 32.21	6 X 1,5 m + 1 X 0,82 m	2050 / 4,520 lb	16,43 / 53.90	3500 Kg / 7,715 lb								
			10,50 / 34.45	7 X 1,5 m	2000 / 4,410 lb	17,11 / 56.13	3450 Kg / 7,605 lb								
			11,32 / 37.14	7 X 1,5 m + 1 X 0,82 m	1900 / 4,190 lb	17,93 / 58.82	3350 Kg / 7,385 lb								
3 / 12.53	2 X 1,5 m	650 Kg / 1,435 lb	12 / 39.37	8 X 1,5 m	1800 / 3,970 lb	19,97 / 65.51	3100 Kg / 6,835 lb								
			12,82 / 42.06	8 X 1,5 m + 1 X 0,82 m	1700 / 3,745 lb	20,79 / 68.20	3000 Kg / 6,610 lb								
			13,50 / 44.29	9 X 1,5 m	1650 / 3,635 lb	21,47 / 70.44	2950 Kg / 6,500 lb								
			14,32 / 46.98	9 X 1,5 m + 1 X 0,82 m	1575 / 3,470 lb	22,29 / 73.13	2875 Kg / 6,340 lb								
3,82 / 12.53	2 X 1,5 m + 1 X 0,82 m	600 Kg / 1,320 lb	15 / 49.21	10 X 1,5 m	1500 / 3,310 lb	24,61 / 80.74	2700 Kg / 5,950 lb								
			15,82 / 51.90	10 X 1,5 m + 1 X 0,82 m	1400 / 3,90 lb	25,43 / 83.43	2600 Kg / 5,730 lb								
			16,50 / 54.13	11 X 1,5 m	1300 / 2,865 lb	26,11 / 85.66	2500 Kg / 5,510 lb								
			17,32 / 56.82	11 X 1,5 m + 1 X 0,82 m	1150 / 2,535 lb	26,93 / 88.35	2350 Kg / 5,180 lb								
4,5 / 14.76	3 X 1,5 m	550 Kg / 1,210 lb	18 / 59.05	12 X 1,5 m	1075 / 2,370 lb	28,97 / 95.04	2175 Kg / 4,795 lb								
			18,82 / 61.74	12 X 1,5 m + 1 X 0,82 m	975 / 2,150 lb	29,79 / 97.73	2075 Kg / 4,575 lb								
			19,50 / 63.97	13 X 1,5 m	900 / 1,985 lb	30,47 / 99.96	2000 Kg / 4,410 lb								
5,32 / 17.45	3 X 1,5 m + 1 x 0,82 m	400 kg / 880 lb	19,50 / 63.97	13 X 1,5 m	900 / 1,985 lb	32,11 / 105.35	1700 Kg / 3,750 lb								
<b>Weights for full length extension floor (If they are assembled, their weight must be subtracted from the maximum load for all configurations)</b>															
Machine length (m/ft)	32,11	30,47	28,97	26,93	25,43	24,61	22,29	21,47	19,97	17,93	16,43	15,61	13,29	12,47	10,97
	105.35	99.96	95.04	88.35	83.43	80.74	73.13	70.44	65.51	58.82	53.90	51.21	43.60	40.91	35.99
Weight for full length ext. (Kg/lb)	605	570	540	502,5	472,5	455	407,5	390	360	322,5	292,5	275	227,5	210	180
	1,333	1,256	1,190	1,107	1,041	1,003	898	859	793	711	645	606	501	463	397

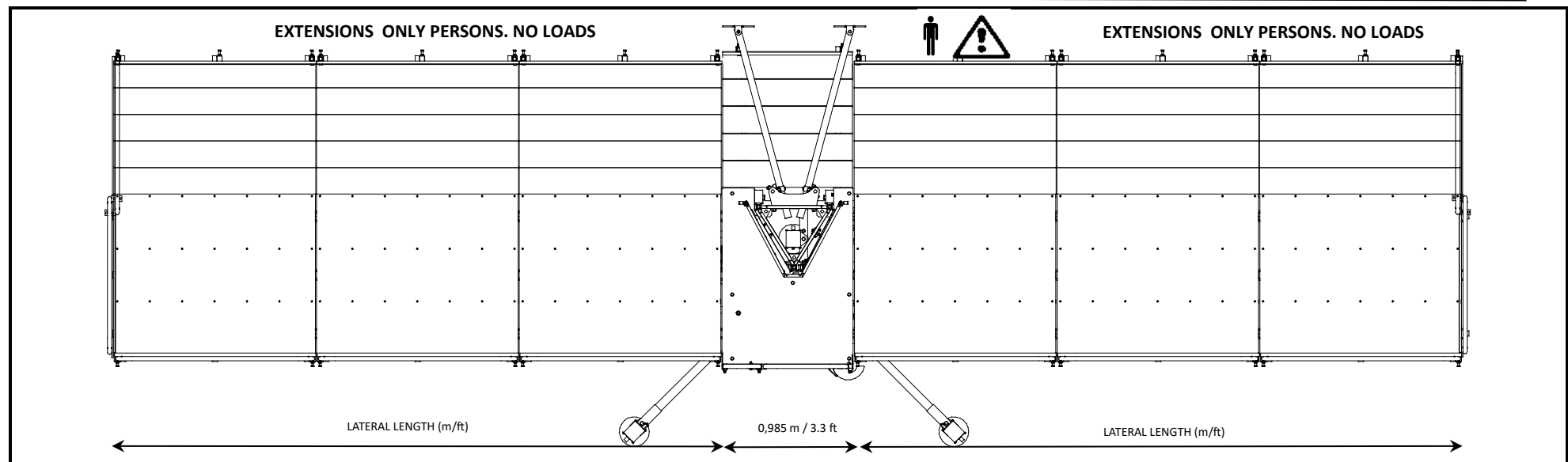

### PEC 120 SINGLE MAST WORK PLATFORM

Lateral length (m/ft)	Modules	Maximum load	LOADING EXAMPLES	
			Total length (m/ft)	Maximum load
0,82 / 2.69	1 X 0,82 m	<b>900 Kg / 1,985 lb</b> (1person + 820 Kg)	2,63 / 8.62	<b>1800 Kg / 3,970 lb</b> (2p.+ 1640 Kg)
1,5 / 4.92	1 X 1,5 m	<b>850 Kg / 1,875 lb</b> (1person + 770 Kg)	3,99 / 13.09	<b>1700 Kg / 3,750 lb</b> (2p.+ 1540 Kg)
2,32 / 7.61	1 X 1,5 m + 1 X 0,82 m	<b>775 Kg / 1,710 lb</b> (1person + 695 Kg)	5,63 / 18.47	<b>1550 Kg / 3,420 lb</b> (2p.+ 1390 Kg)
3 / 9.84	2 X 1,5 m	<b>700 Kg / 1,545 lb</b> (1person + 620 Kg)	6,99 / 22.93	<b>1400 Kg / 3,090 lb</b> (2p.+ 1240 Kg)
3,82 / 12.53	2 X 1,5 m + 1 X 0,82 m	<b>600 Kg / 1,320 lb</b> (1person + 520 Kg)	8,63 / 28.47	<b>1200 Kg / 2,650 lb</b> (2p.+ 1040 Kg)
4,50 / 14.76	3 X 1,5 m	<b>550 Kg / 1,210 lb</b> (1person + 470 Kg)	9,99 / 32.77	<b>1100 Kg / 2,420 lb</b> (2p.+ 940 Kg)

**Weights for full length extension floor (If they are assembled, their weight must be subtracted from the maximum load for all configurations)**

<b>Machine length (m/ft)</b>	9,99 / 32.77	8,63 / 28.47	6,99 / 22.93	5,63 / 18.47	3,99 / 13.09	2,63 / 8.62
<b>Weight for full length ext. (Kg/lb)</b>	180 / 397	155 / 342	120 / 265	95 / 210	60 / 132	35 / 77

- SET UPS IN THIS TABLE ARE MERELY INFORMATIVE AND MAY VARY DUE TO MACHINE MODULARITY.
- LOAD VALUES INCLUDE PERSONNEL, TOOLS AND MATERIALS WEIGHT.
- EXTENSIONS OF PLATFORM DECKS SHALL ONLY BE USED WHILE WORKING. PLACING LOADS ON THEM IS FORBIDDEN.
- LOADS MUST BE EVENLY DISTRIBUTED ALONG THE PLATFORM.
- ON SINGLE MAST SET UPS, LATERAL LENGTHS SHALL BE IDENTICAL.
- THE MAXIMUM ALLOWED FORCE FOR HAND TOOLS USED IN THE WORK PLATFORM IS 1500 N

**MOUNTING COMPATIBILITY WITH PRE-2009 PEC 120**

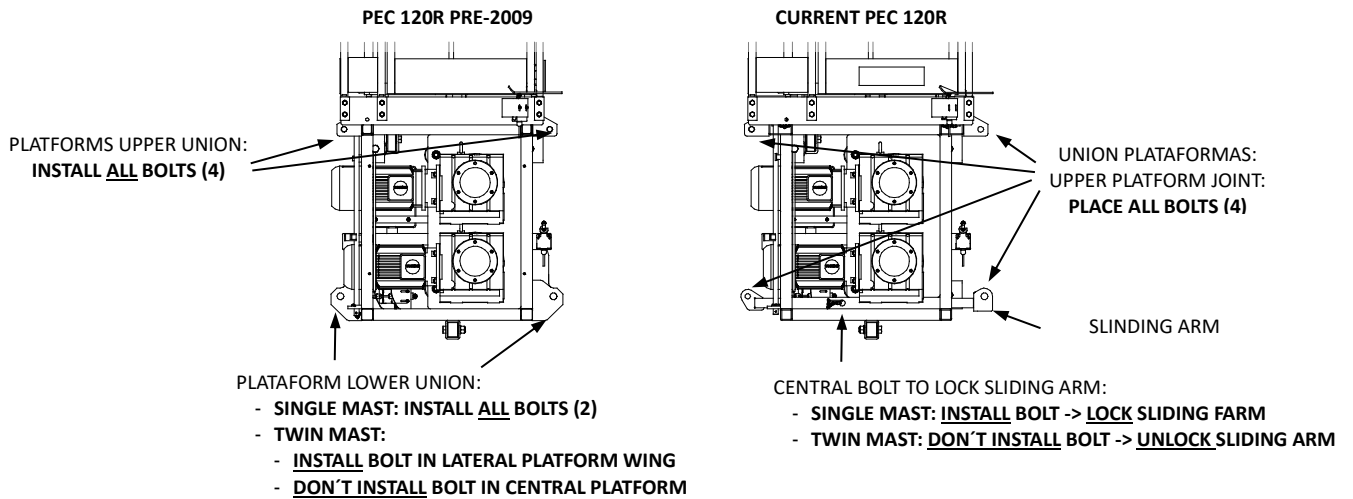

**ASSEMBLY PEC 120R TWIN MAST**

