



www.alba.es

CANOPY BRANDS EUROPE, S.L.U.  
Polígono Ind. Bayas c/ Suzana Parc.134  
09200 MIRANDA de EBRO (Burgos)  
☎ (+34) 947 347 820  
✉ : [comercial@alba.es](mailto:comercial@alba.es) ; 🌐 : [www.alba.es](http://www.alba.es)

## RACK & PINION TRANSPORT PLATFORM

# PT 1200/1000F



### USER GUIDE

- INSTALLATION, USE & MAINTENANCE INSTRUCTIONS
- SPARE PARTS LIST

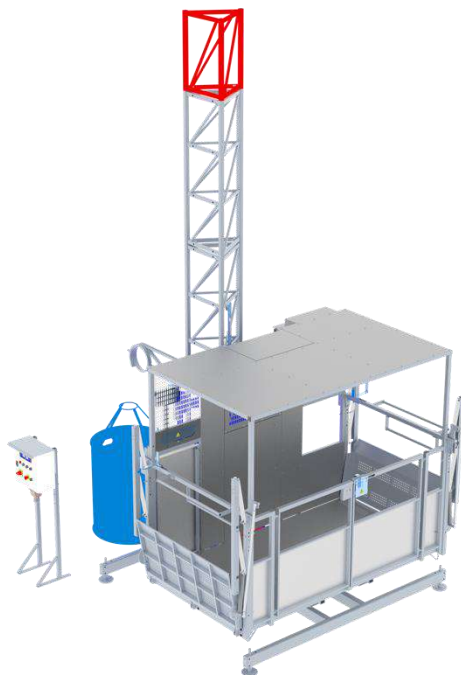

Machine No.:

Model:

Year of manufacture:

Electric connection:

**KEEP THIS GUIDE FOR FUTURE REFERENCE**



**CONTENTS**

<b>1. DESCRIPTION OF THE MACHINE .....</b>	<b>3</b>
1.1 Introduction .....	3
1.2 General information .....	4
1.3 Technical data .....	5
1.4 Main components.....	6
1.5 Main dimensions .....	8
1.6 Hoist safety devices .....	11
1.7 Additional data of the hoist .....	12
<b>2. ASSEMBLY OF THE MACHINE.....</b>	<b>13</b>
2.1 Introduction .....	13
2.2 Hoist transport.....	13
2.3 Machine erection procedure .....	15
Step 1 Site preparation and foundation .....	15
Step 2 Base to ground positioning and fastening .....	15
Step 3 Assembly of motor group and electric connection .....	16
Step 4 Erection of the mast .....	18
Step 5 Installing mast anchorage.....	20
Step 6 Installing end track cams and final mast.....	23
Step 7 Assembly of cable holder .....	24
Step 8 Installing base enclosure .....	25
Step 9 Installing landing doors.....	26
· SWINGING DOOR LANDING GATES (USUALLY TO SLAB) .....	26
· SLIDING DOOR LANDING GATES (USUALLY TO SCAFFOLD) .....	28
Step 10 Test of parachute .....	30
Step 11 Installing landing levels cams .....	31
Step 12 Programming landing levels .....	32
Step 13 Installing landing levels call system – OPTION.....	33
Step 14 Installing aux. crane for mast erection – OPTION.....	35
Step 15 Installing roof and mast protector .....	35
2.4 Dismantling the hoist.....	36
<b>3. USING THE HOIST .....</b>	<b>37</b>
3.1 Introduction .....	37
3.2 Using “MANUAL” Mode.....	38
· A) TRANSPORT PLATFORM PT-1200/1000F-2V .....	38
· B) TRANSPORT PLATFORM PT-1200/1000F-1V .....	39
3.3 Using “AUTO” Mode .....	40
· AUTO MODE – SELECTOR “PERSONS” .....	40
A) TRANSPORT PLATFORM PT-1200/1000F-2V .....	40
B) TRANSPORT PLATFORM PT-1200/1000F-1V .....	41
· AUTO MODE – SELECTOR “ONLY LOADS” .....	42
3.4 Safety messages in display.....	43
3.5 Emergency lowering .....	44
3.6 Checking hoist operation before commissioning.....	45
3.7 Using the hatch.....	45
3.8 Notes on the use of -1C platforms (equipped with BATT) .....	46
3.9 Applications and uses forbidden .....	46

<b>4. SAFETY DEVICE. PARACHUTE FPC-1000</b> .....	<b>47</b>
4.1 Introduction .....	47
4.2 Features .....	48
4.3 Installing the parachute .....	49
4.4 Parachute testing .....	50
4.5 Actions to take if safety device is activated .....	52
4.6 Replacement of parachute .....	52
<b>5. MAINTENANCE OF THE MACHINE</b> .....	<b>53</b>
5.1 DAILY Maintenance .....	53
5.2 PERIODIC Maintenance schedule .....	54
5.3 Instructions for troubleshooting .....	61
5.4 Maintenance record. ....	62
5.5 Trouble record .....	65

**LOAD WEIGHT CONTROL CALIBRATION INSTRUCTIONS****TEST CERTIFICATE****EC DECLARATION OF CONFORMITY****TÜV-PARACHUTE CERTIFICATE****ELECTRICAL SCHEME****ELECTRICAL PARTS****SPARE PARTS LIST**

The user's manual must be kept in good condition. This document contains 68 pages.  
Canopy brands Europe S.L.U. reserves the right of incorporating contents or modifications at any time with the purpose of improving both the machine and the information available on the same.



Copyright © Canopy brands Europe S.L.U.  
Rev. 1.5: Jan. 2025

## 1. DESCRIPTION OF THE MACHINE

### 1.1. Introduction.

Prior to erection and use, all users must read this manual. A thorough reading is recommended for full compliance with safety regulations.

This manual is delivered with the hoist, and its purpose is to give instructions for proper handling during transportation, erection and maintenance, in compliance with the provisions of EU Directive 2006/42/CE on safe machinery. This instruction manual deals with proper use of the machine as well as proper erection and maintenance.

The manufacturer reserves the right to modify the machine for improvements, so that differences may be found in some manual details. In any case, the manufacturer commits to immediately adapt the manual to the improvements.

#### **Responsibility:**

CANOPY BRANDS EUROPE, S.L.U., declines any responsibility for damage caused by improper use of the machine as consequence of non-compliance with the provisions of the present Manual. Specifically declines any responsibility for damages derived from:

- Non-compliance with the provisions of this manual.
- Improper use of the machine.
- The use of non-original spare parts mentioned in the applicable section of this manual.
- Modifications introduced without express authorisation from the manufacturer.
- Handling by personnel not trained for this purpose.

Only appointed trained personnel may use the machine and only qualified technical personnel acquainted with the machine may operate on any part of the same.

This manual must be available to the user at any time for any type of immediate consultation. In order to maintain it in perfect conditions, keeping always a copy close to the machine is recommended.

In any case, the manual is aimed at knowledge strengthening and as a reminder for the personnel, who must previously be well trained by engineers or supervisors, who at the same time must be very experienced in this machine operation.

### 1.1. General information.

It's based on the principle of geared motor transmission to a rack and pinion mechanism. Components are modular and easy to install. It is simple to use and safe for facade work or rehabilitation, significantly reducing the erection time and man-hours.

This machine has been designed for temporary installation on site and must be used by skilled authorised personnel. Its main advantage is the ability to connect different building stories for lifting or lowering materials and persons in a fast and safe way. Below, please find the main points to bear in mind prior to erection and use of the machine.

- The hoist is designed (CE-model) **for transporting persons and loads**, in open cage, travelling with a minimum gap of 0,5 m. from supporting structure, and vertical speed limited to 12 m/min. When using for transport of persons, cage control will be with "hold-to-run" pushbuttons. Platform also can be used for **transporting loads**, with exterior control board (ground) and increased speed to 24 m/min. In each case follow the conditions of use stated in this manual.
- The machine runs vertically, geared to the mast rack and guided with support rollers.
- Machine operation must be carried out by **appointed personnel** trained in transport platform operation, and the instructions to operate the machine safely.
- Travelling on the hoist is allowed only for **authorized passengers**, instructed by the operator appointed to management of the platform.
- For erection, dismantling, maintenance and repair tasks, only **competent and authorised technical personnel**, trained and qualified with practical experience on said operations, are allowed to travel on the hoist.
- The transport platform enables a mode of operation from the outside as hoist only for loads. When using as hoist for loads, loading and unloading operations must be performed by **instruded people**.
- The machine is designed to tie at appropriate intervals to a supporting structure, as the slabs of the floors of a building, a metallic structure or similar. ALBA include in this user's manual all the information regarding to reaction forces to the structure and to the base ground. It is the responsibility of the responsible technicians on site, to ensure that, both supporting structure and base ground support transmitted loads.

#### WARNING SYMBOLS:



**WARNING:  
IMPORTANT SAFETY INSTRUCTIONS DURING INSTALLATION OR OPERATION IS TO  
BE ENTERED IN TEXT BOXES LIKE THIS, INCLUDING THE WARNING SIGN.**

### 1.3. Technical data.

#### TECHNICAL FEATURES:

	PT-1200-2V	PT-1200-1V	PT-1000F-2V	PT-1000F-1V
Motor control:	FREQUENCY CONVERTER	DIRECT	FREQUENCY CONVERTER	DIRECT
Vertical speed:	12÷20 m/min	20 m/min	12÷20 m/min	20 m/min
Maximum capacity:	1.200 Kg	1.200 Kg	1.000 Kg	1.000 Kg
	7 pax + 500 Kg	12 pax	7 pax + 300 Kg	10 pax
Cage dimensions (LxWxH):	2.000 x 1.400 x 2.100 mm		2.500 x 1.400 x 2.100 mm	
Maximum height (*):			120 m	
Anchorage each (max.):			6 m	
Height over las anchorage:			1,5 m	
First anchorage height:			6 m	
Loading height to ground			400 mm	
Mast:			Triangle	
Length:			1,5 m	
Weight:			48 Kg	
Maximum load (assembly):			EN-16719; 2006/42/CE	

#### ELECTRICAL DATA

	PT-1200-2V PT-1000F-2V	PT-1200-1V PT-1000F-1V
Motor power:	2 x 3 KW (50 Hz) 2 x 3,6 KW (60 Hz)	
Input power connection:	380÷460V – 50/60 Hz	400 V – 50Hz 440 V – 60Hz
Power consumption:	7,5 KW	7 KW
Nominal current:	20 A	15 A
Supply power:	20 KVA	
Overload protection (*):	3 x 25 A	
Differential protection (*)		
Calibre:	25 A	
Sensitivity:	300 mA	
Control voltage:	48 V	
Auxiliary hand tools socket:	230 V – 50/60 Hz 1200 W	
Cable section:	4 x 6 mm <sup>2</sup>	

(\*) Elements required on main feed switchboard

#### ACOUSTIC DATA

<b>A-weighted emission sound pressure level, LpAd</b>	<b>&lt;70dB</b>
<b>Place: Operation point</b>	

**1.4. Main components.**

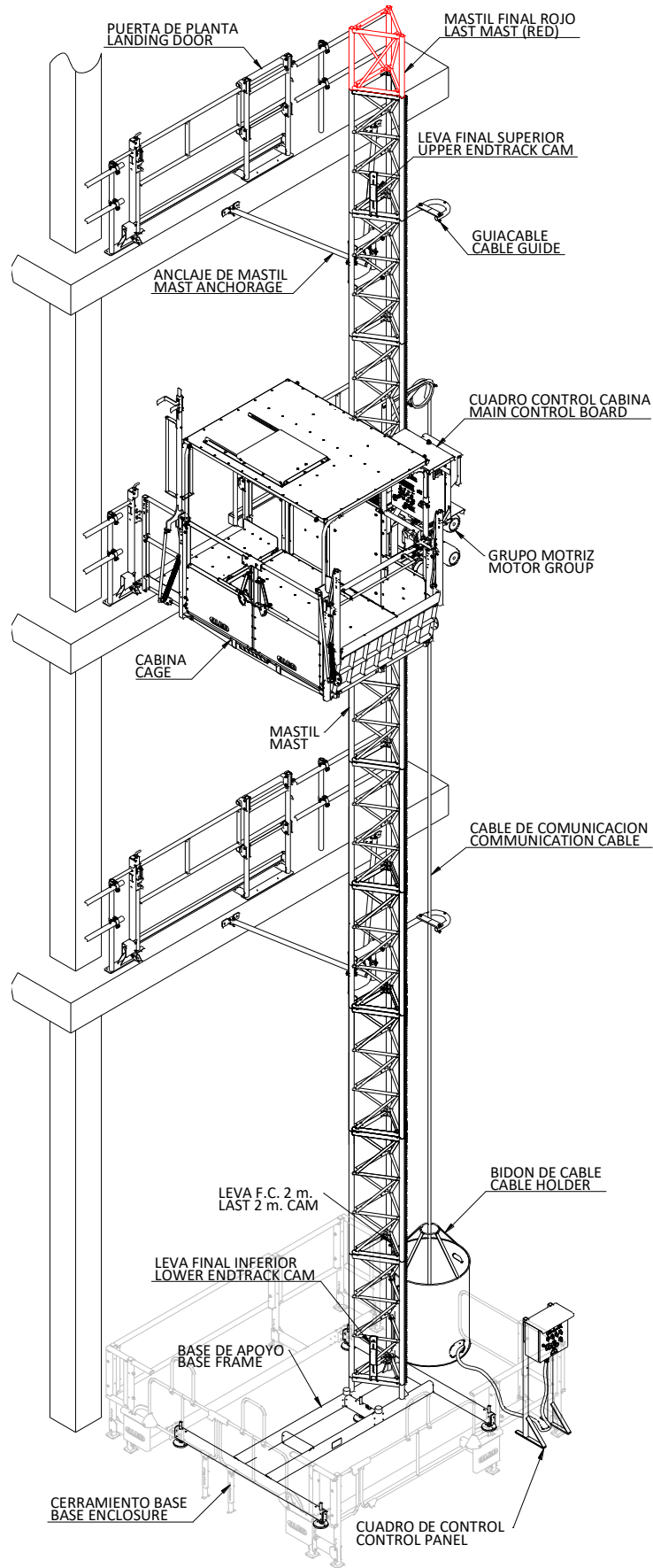

**ASSEMBLY EXAMPLE. TRANSPORT PLATFORM PT-1200/1000F**

- MAST BASE SUPPORT:**  
 Main structure that is used as a support for the hoist and for the column of masts. It transmits the efforts generated to the ground and it's surrounded with a safety enclosure that avoids the risk of damage. The base incorporates absorbers to avoid blows of the cabin with the base. Close to the base electrical switchboard for electrical supply is installed.
- MAST:**  
 Modular structure for the ascent of the machine. Modular triangle structure of 1,5 m. The mast has a welded rack for the movement of the platform over it. They are designed for his union by means of screws and for the anchorage to a vertical structure of support to intervals
- MOTOR GROUP:**  
 Structure that incorporates and the system of motor gear system and that provides the movement to the elevator. It includes both the motor gears and the safety systems to control the movements of the machine, the overload system, and the floor selector.
- CAGE:**  
 Metallic open structure for the transport of persons and loads. it includes doors for the loading and unloading of the machine, and auxiliary catwalk for assembly operations, all of them equipped with safety microswitches.

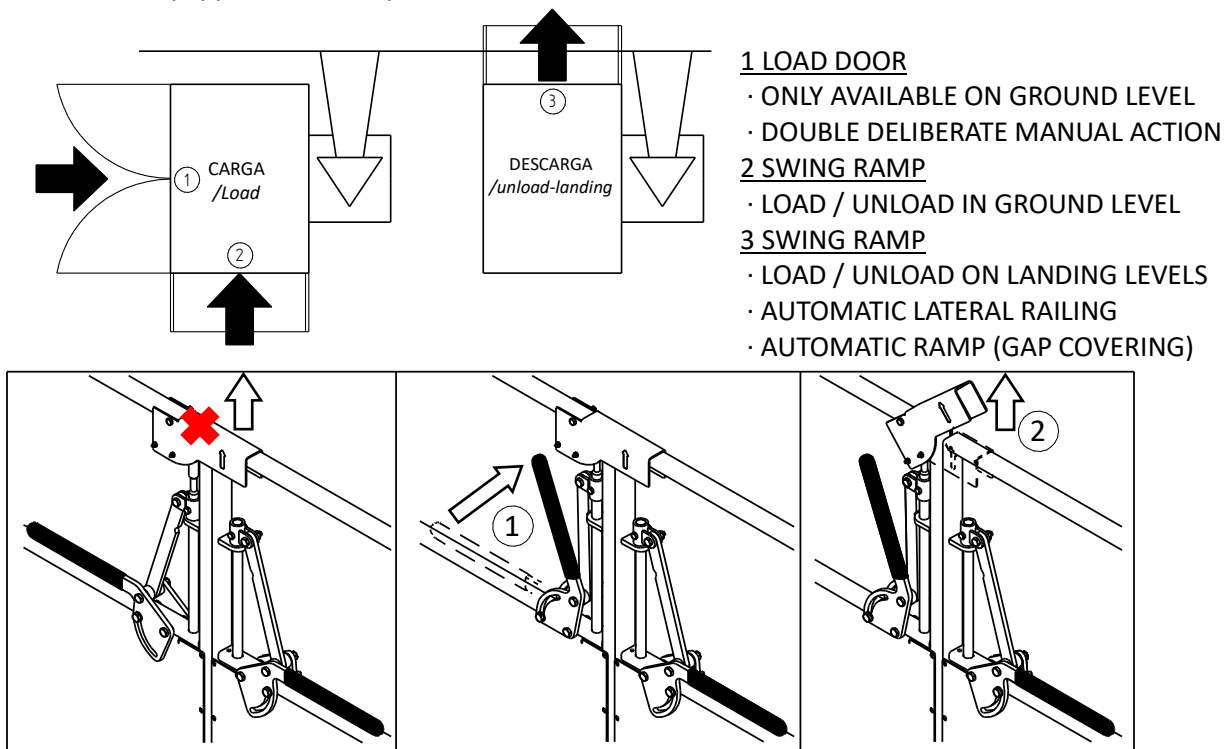

ACTION REQUIRED TO OPEN LOAD DOOR -1-

- ANCHORAGE:**  
 System of mast anchorage to external support structure. It consists in a bracket screwed to and a pair of telescopic pipes for adjusting to external support structure.
- POWER SWITCHBOARD:**  
 It contains main components of electrical equipment of the machine, and communicates both the cage control panel, and the supply board on the ground, with proper connectors.
- CABLE BIN:**  
 Keep the cable of the machine when moving. The bin stores communication cable coiling it.
- FINAL MAST MODULE:**  
 Mast module without rack that is installed in the top limit of the column of masts. It prevents that the machine exceeds the top limit of the mast, and its red colour allows immediate identification.

**1.5. Main dimensions.**

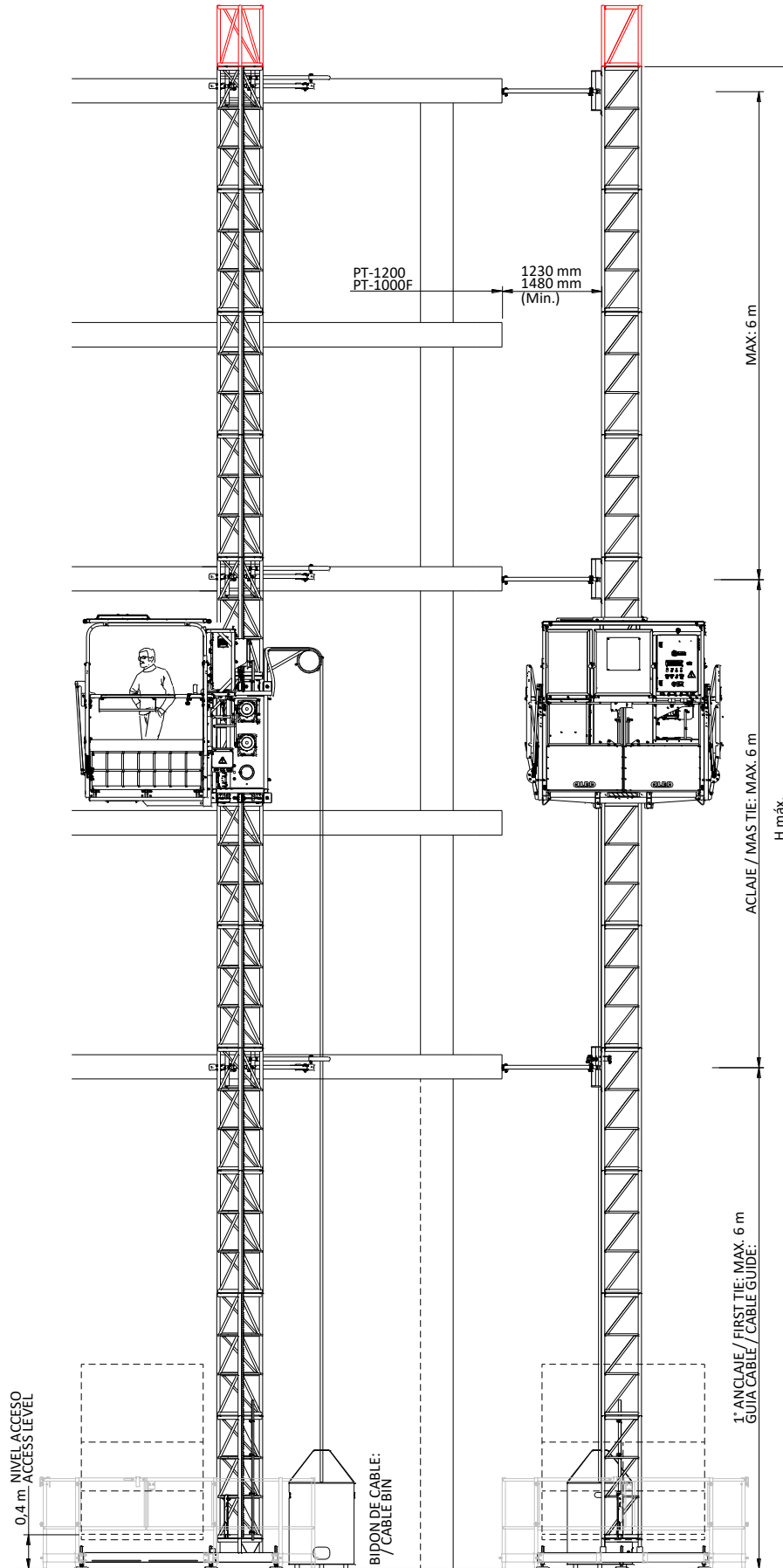

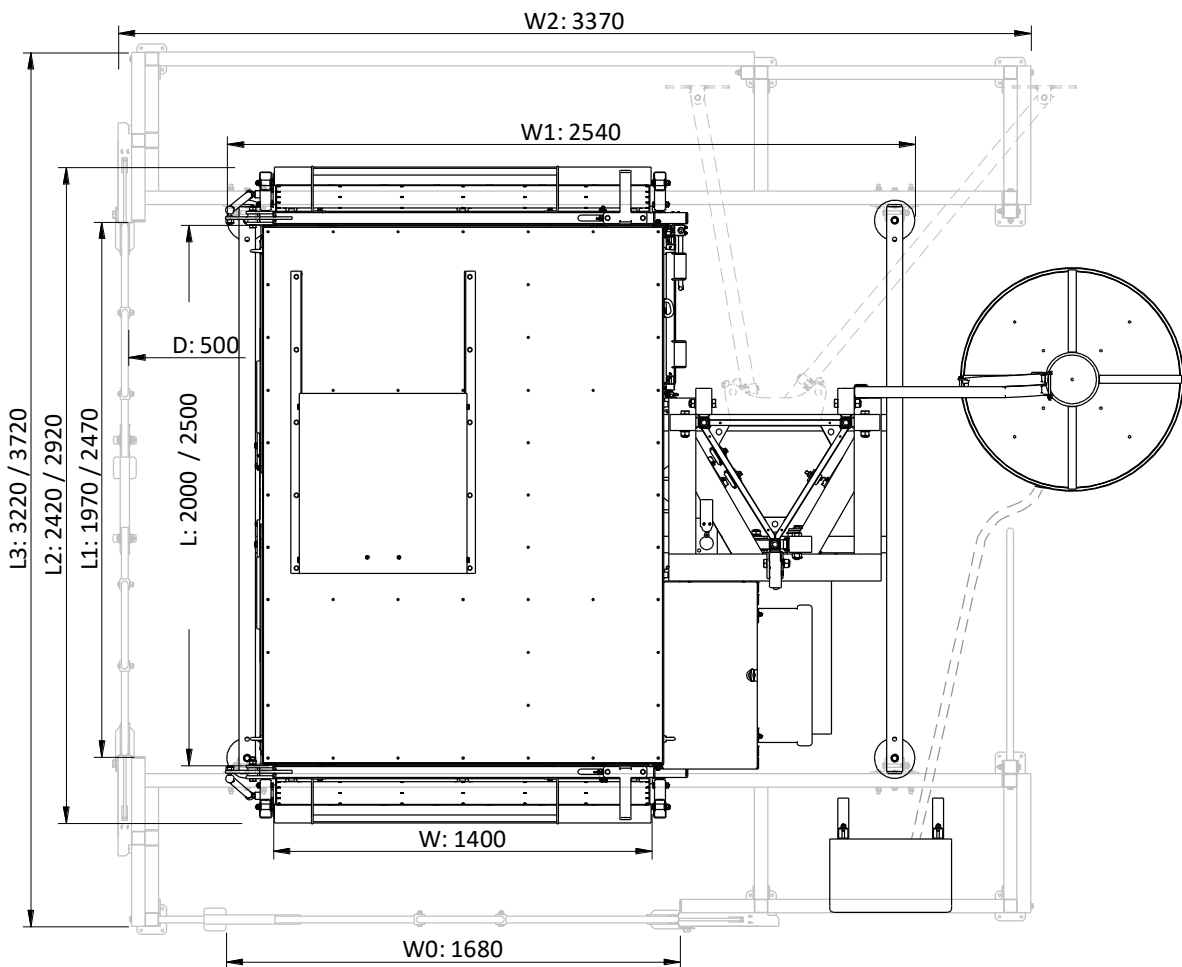
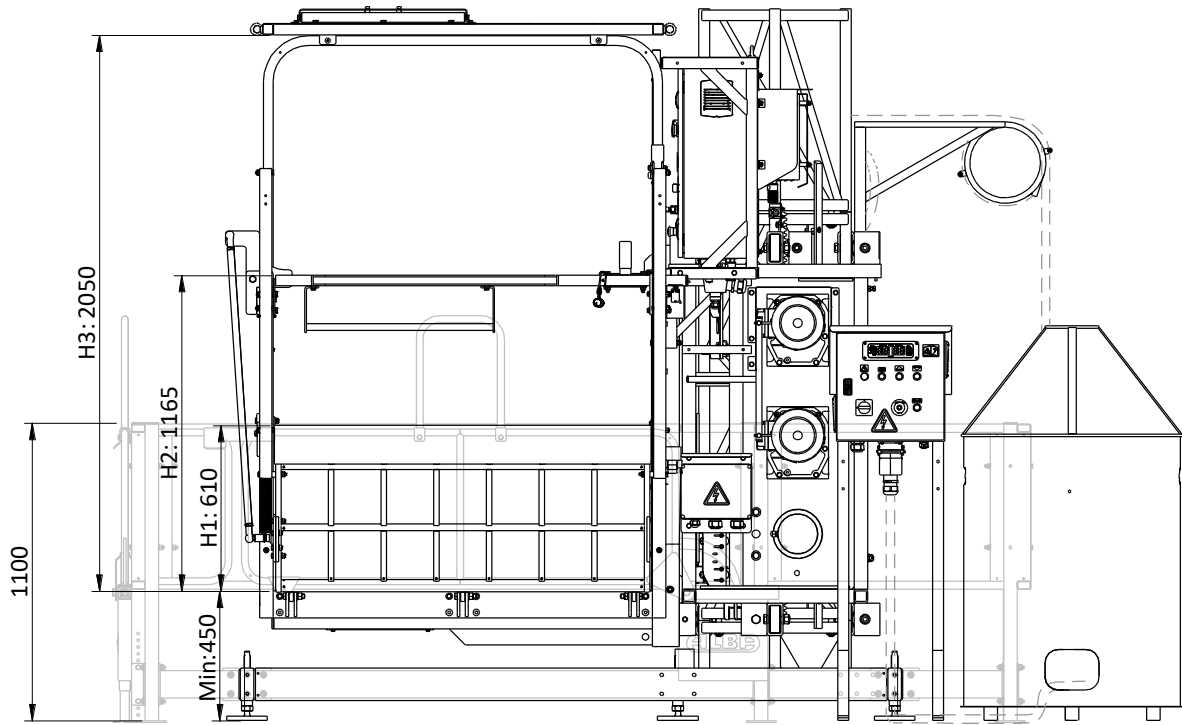

**MAIN DIMENSIONS. TRANSPORT PLATFORM PT-1200/1000F**

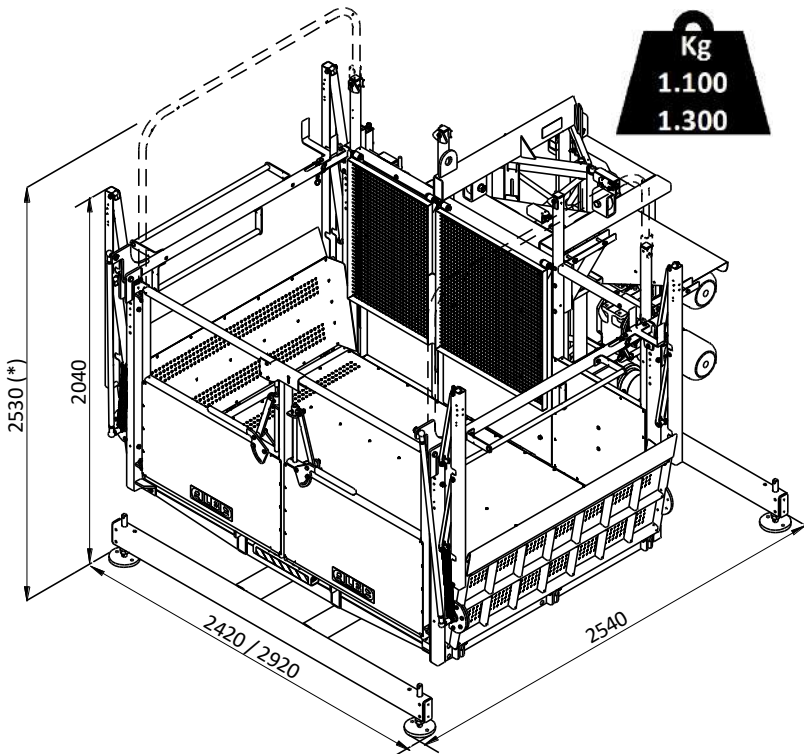

**MAIN TRANSPORT SET**

(\*)REMOVABLE

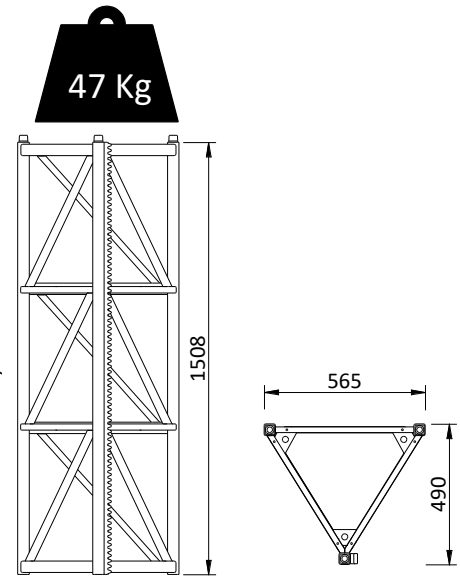

**TRIANGLE MAST MODULE 086.2**

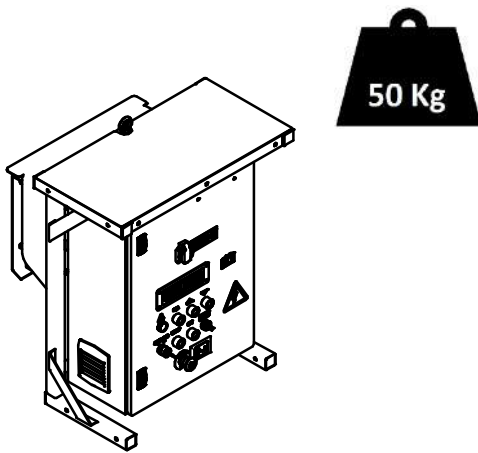

**CABIN MAIN CONTROL PANEL**

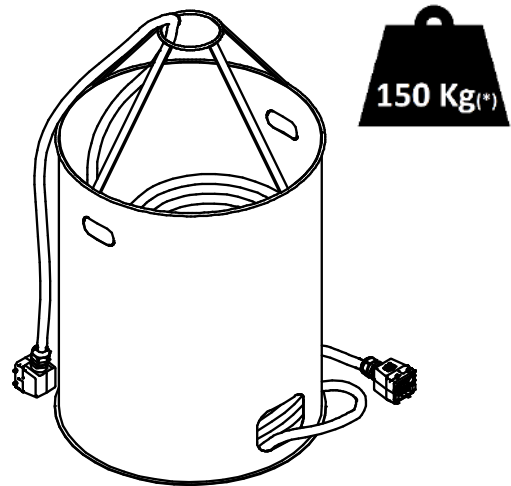

**CABLE HOLDER**

(\*) FOR L=50m

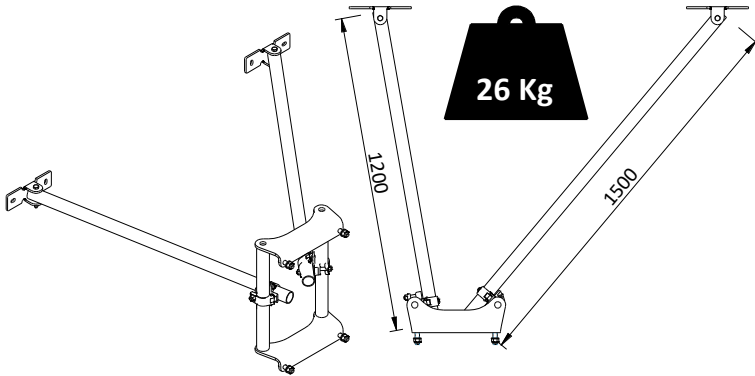

**ANCHORAGE SET**

**ANCHORAGE 161.81 – PT 1200**

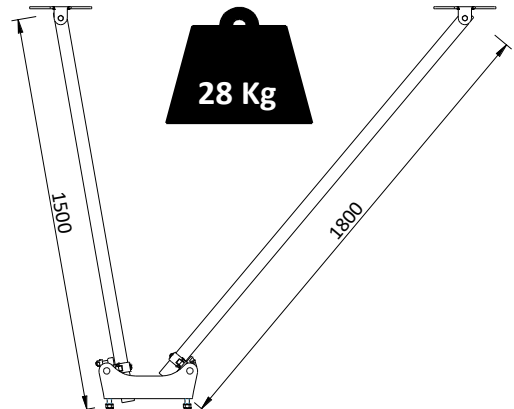

**ANCHORAGE 161.82 – PT 1000F**

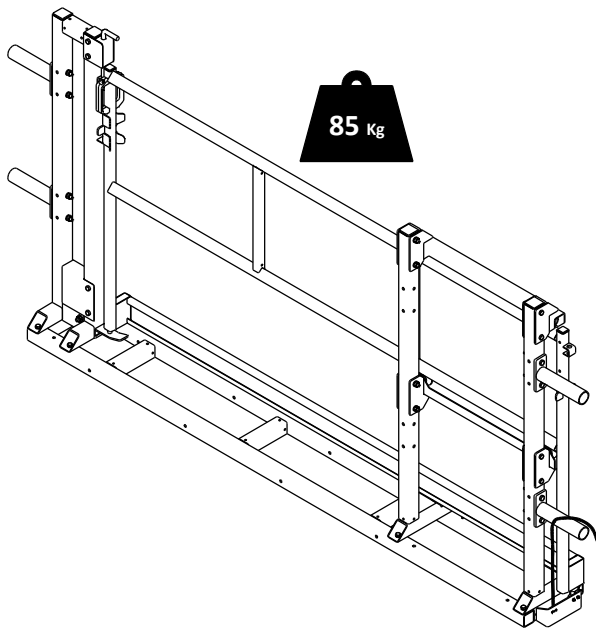

SLIDING LANDING DOOR

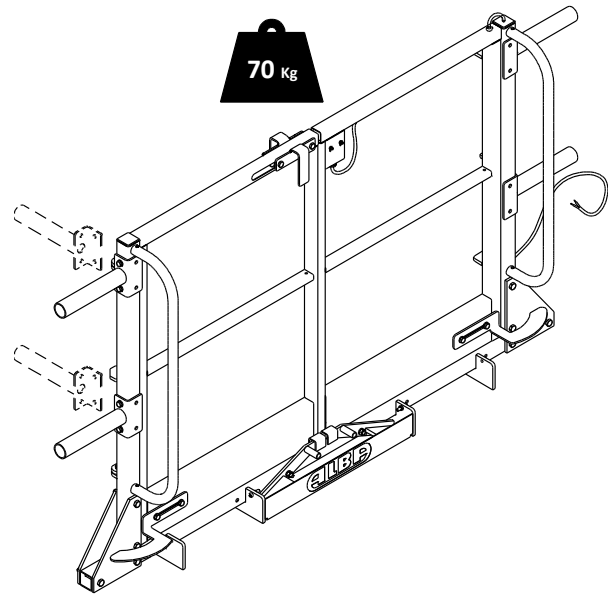

SWINGING LANDING DOOR

### 1.6. Safety devices of the hoist.

- a) Gearmotors with **electromagnetic brakes** (friction type) capable to brake speeds of 20 m/min. (and even 25% overspeed) with a delay of 0.1 up to 0.2 g. with maximum load.
- b) Rubber buffers to damp eventual frame impacts against the base.
- c) Cage roof finished in hot galvanized steel.
- d) Upper and lower limit switches. Stop the lowering and lifting movements of the cage when reaching the lower and upper stops located at the first and next to last masts.
- e) Safety limit switch. Operate in case of failure of upper or lower limit switches.
- f) Mast presence detector, to be used mainly during mast erection.
- g) Microswitches for opening the cage doors, and for landing gates with mechanical interlocking device.
- h) Electromechanical interlocking on cage load door, to avoid door opening out of ground level.
- i) Unload ramps with automatic bridge and lateral protection railing included, for safety opening from the inside/outside of cage.
- j) Landing doors interlock prevents opening unless the cage is on landing level and ramp is opened.
- k) Limit switch to stop at 2 m elevation. Movement under-2m with "hold-to-run"
- l) **Manual Emergency lowering** in case of power failure (operated from the cage).
- m) **Safety device (Overspeed emergency brake -PARACHUTE-)**, to control the lowering speed.
- n) Base enclosure of 1,1 m height, with a distance to any moving part of the hoist of 0,5 m. and microswitch to prevent platform movements if enclosure door is open.
- o) Platform floor of non-slipping galvanized steel.
- p) End mast (in red), without rack, to prevent the cage from running off in case of failure of other systems.

**1.7. Other data of the hoist.**
**NOISE EMISSION DECLARATION**

	Condition
A-weighted emission sound pressure level, $L_{pA}$ :	Outside cage 71 dB
Uncertainty $K_{pA}$	3 dB

Values determined according to the acoustic test given in EN 12158-1 with use of basic international standards EN ISO 3744 y EN ISO 4871.

**Note:**

Noise emission values and uncertainty represent un upper limit of the range in which the measured values are susceptible to be present.

Temperature range for use:	-15°C – 45°C
Relative humidity:	30 % – 90 %
Max. height for installation:	1000 m (**)
Max. wind speed (SERVICE):	55 Km/h
Max. wind speed (ERECTION):	45 Km/h
Max. wind speed (OUT OF SERVICE *):	130 Km/h

(\*) Position OUT OF SERVICE corresponds with hoist al the lowest point and power supply disconnected.

(\*\*) For installation in locations above 1000 m of height., and if the temperature exceeds 45° C, ask to manufacturer for limitations.

**IMPORTANT NOTE:**

IN ACCORDANCE WITH THE STANDARD EN 16719:2014, THE PLATFORM SHOULD BE EQUIPPED WITH A FALLING OBJECTS PROTECTIVE GUARD. THE GUARD MAY BE REMOVABLE FOR INSTALLATION AND MAINTENANCE TASK, BUT ONLY A SITE-SPECIFIC RISK ASSESSMENT INDICATES THAT THERE IS MINIMAL RISK OF OBJETS FALLING ON THE PLATFORM, MAY THE FALLING OBJETS GUARD BE REMOVED. ALBA SUPPLIES THE GUARD WITH THE MACHINE, SO IT IS THE RESPONSIBILITY OF THE INSTALLER A RISK ANALYSIS AND THE USE OF THE TRANSPORT PLATFORM WITHOUT PROTECTION GUARD.

## 1. ASSEMBLY OF THE MACHINE

### 2.1. Introduction.

The following section is dedicated to the safely assembly of the machine. The installation of the hoist can only be performed by qualified personnel authorized to travel on it.



**WARNING:**

**TO MOUNT THE ELEVATOR SHALL BE USED PROTECTIVE EQUIPMENT AGAINST FALLS FROM HEIGHT (ACCORDING TO EN 358, EN 361, EN 364) AND IN ANY CASE A PROTECTIVE HELMET FOR THE HEAD (ACCORDING TO EN 397), PLUS ADDITIONAL MEANS OF PROTECTION.**



It is important to follow the instructions in detail, to avoid risks in the assembly and disassembly process. The user is obliged to observe, by himself, and for those working in the vicinity, all sources of additional risk, and to comply with all applicable safety standards for the type of equipment used.

### 2.2. Hoist transport and coupling.

The hoist is supplied unmounted, unless specifically indicated otherwise. For the coupling of main components of the hoist it's necessary to use a crane.

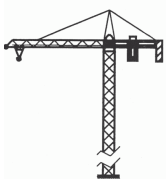

**IMPORTANT:**

**TO ASSEMBLE THE COMPONENTS AND THE ASSEMBLY WILL USE A TRUCK LIFT CRANE, OR IF AVAILABLE, ALSO A TOWER CRANE CAN BE USED FOR IT.**



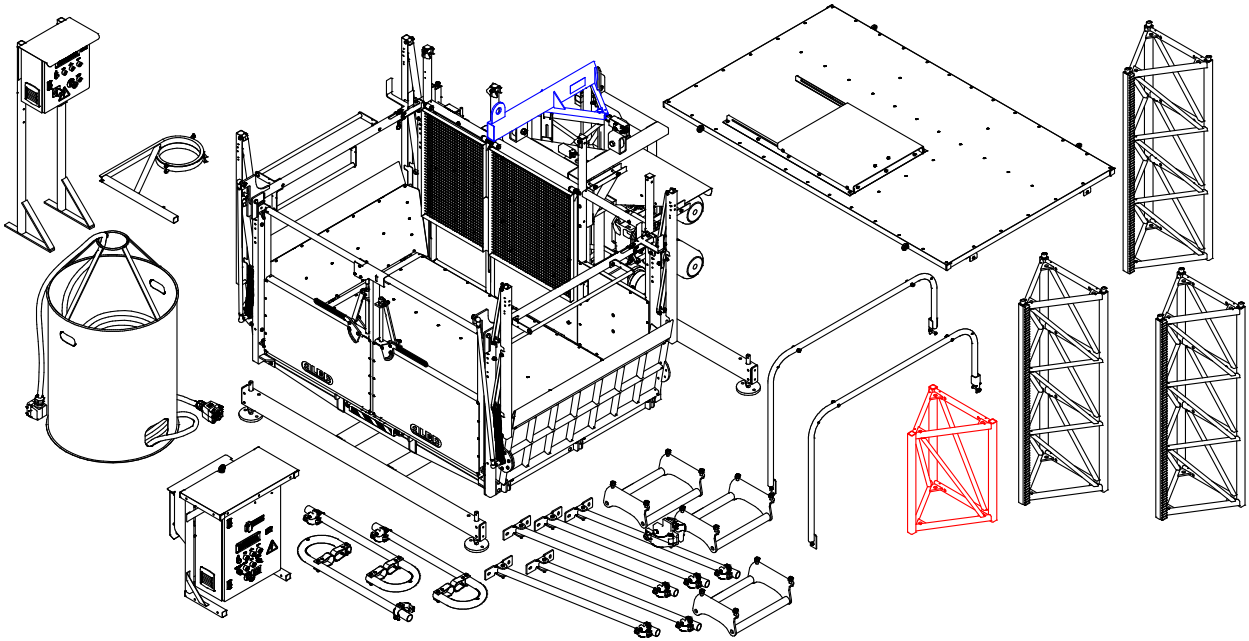

ELEMENTS FOR HOIST ASSEMBLY. USE A CRANE O FORKLIFT

Kg  
 1.100  
 1.300

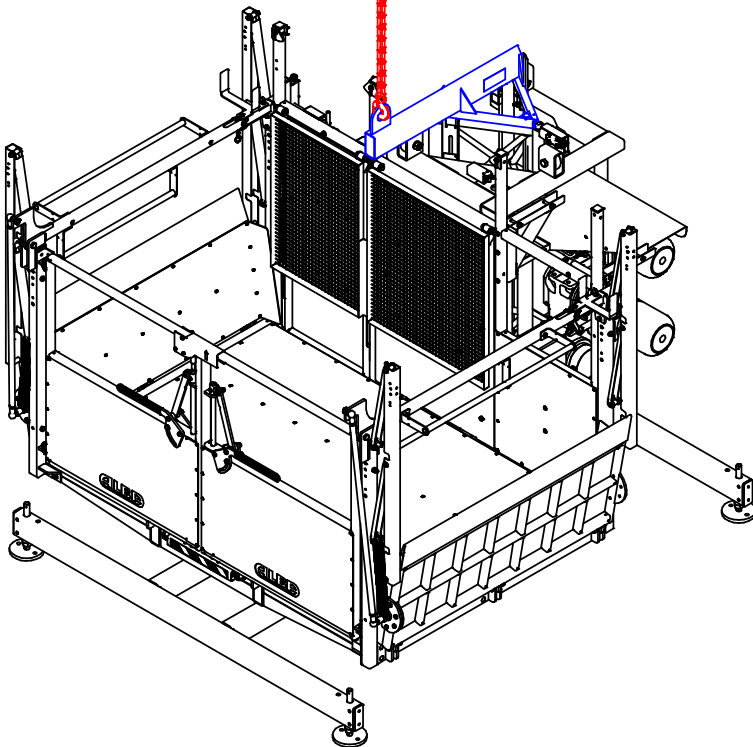

HANDLE OF ASSEMBLED HOIST

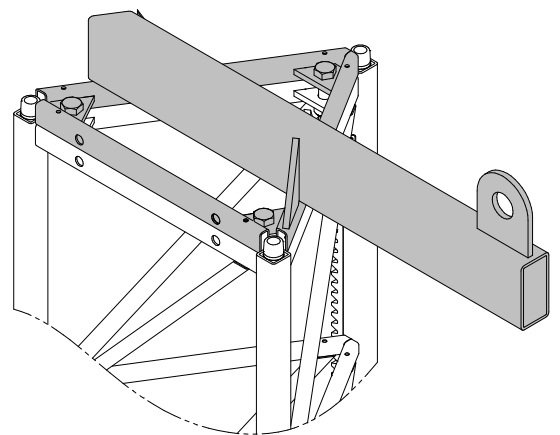
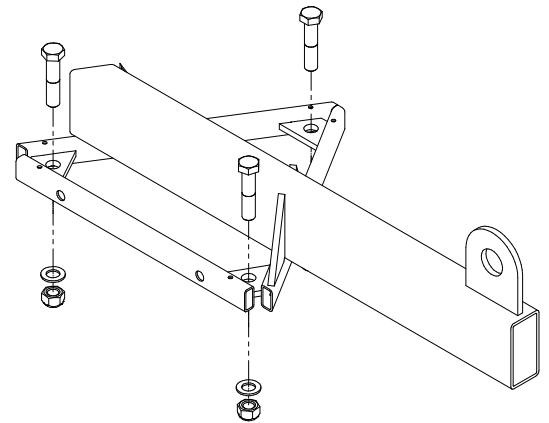

TRANSPORT HOLDER Ref: 094.12

### 2.3. Machine erection procedure:

- Step 1. Site preparation and foundation

TRANSMISSION OF LOADS TO GROUND PT-1200 / 1000F		
Height [m]	TOTAL TOAD (EST.) [KN]	TOTAL LOAD (DYN.) [KN]
10	27,22	40,56
20	30,36	43,70
30	33,50	46,84
40	36,64	49,98
50	39,78	53,12
60	42,92	56,26
70	46,06	59,40
80	49,20	62,54
90	52,34	65,68
100	55,48	68,82
110	58,61	71,96
120	61,75	75,10

(x225) = [lbf]

- Step 2. Base to ground positioning and fastening.

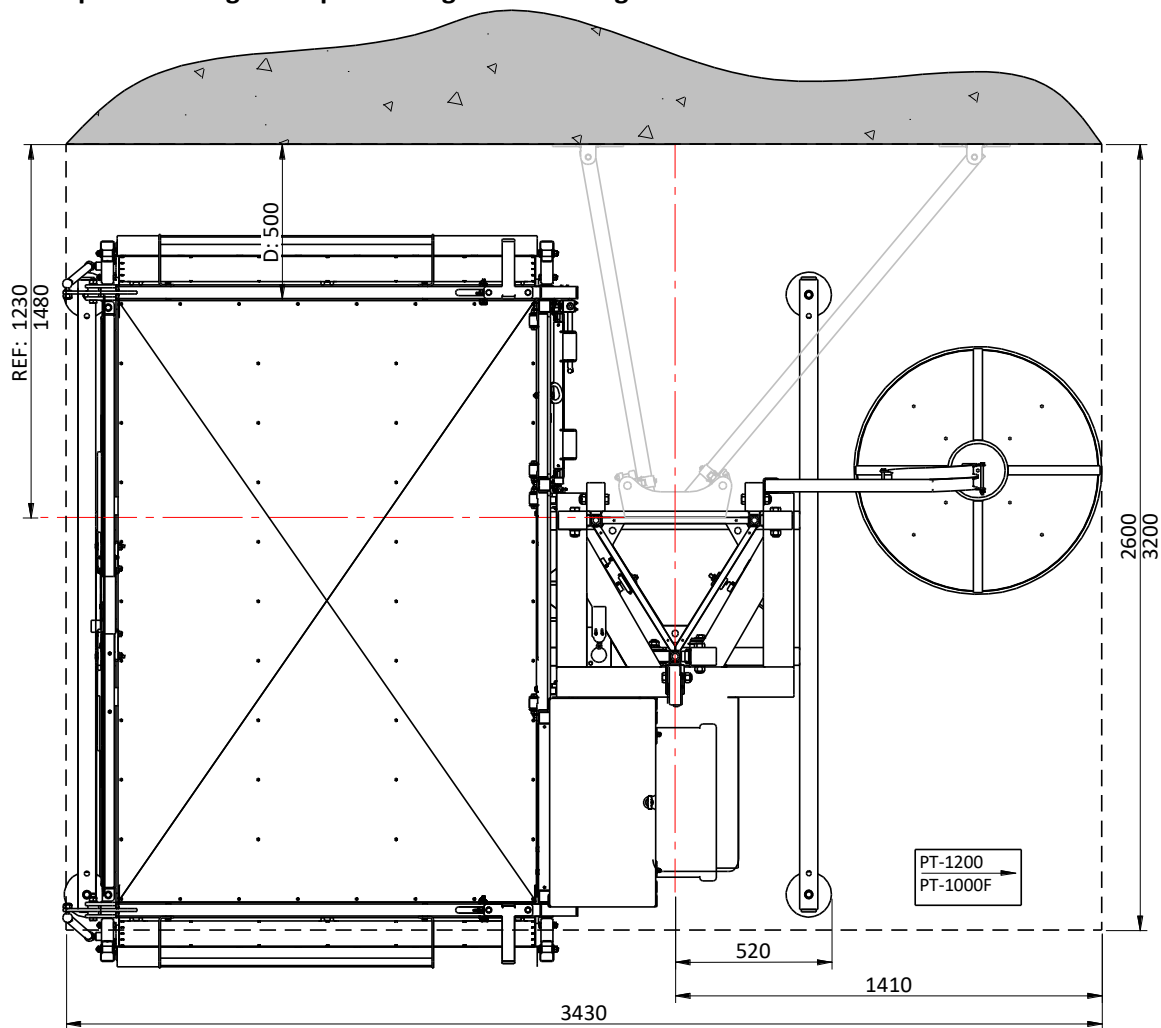

**POSITIONING THE HOIST ON THE GROUND**

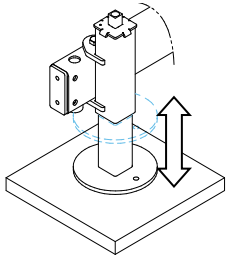

BASE JACKS TO SOIL

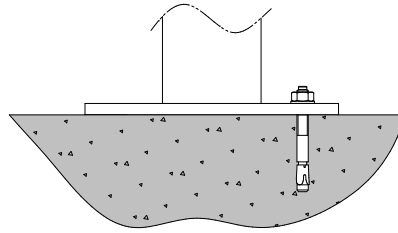
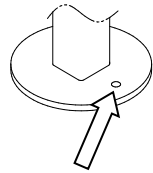

FITTING TO GROUND RECOMENDATION

**INSTALLATION DETAILS**

$D_o$	Drill diameter	10 mm
$H_1$	Minimum drill depth	70 mm
$L_r$	Screw length	42 mm
$H_{nom}$	Min. mounting depth	50 mm
$T_{ins}$	Torque	30 N·m



**ATTENTION:**

FOR HOIST POSITIONING IT'S REQUIRED A MINIMUM SUPPORT AREA WITH DIMENSIONS 2.600[3200] X 3.500 mm, INCLUDING CABLE BIN.

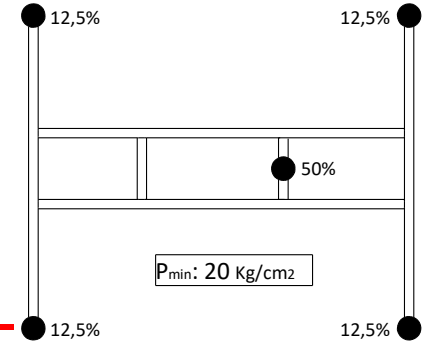
MAKE SURE THE RESISTANCE OF THE GROUND TO WITHSTAND THE MAXIMUM LOADS TRANSMITTED BY THE PLATFORM.

**DISTRIBUCION DE PESO / Load distribution**

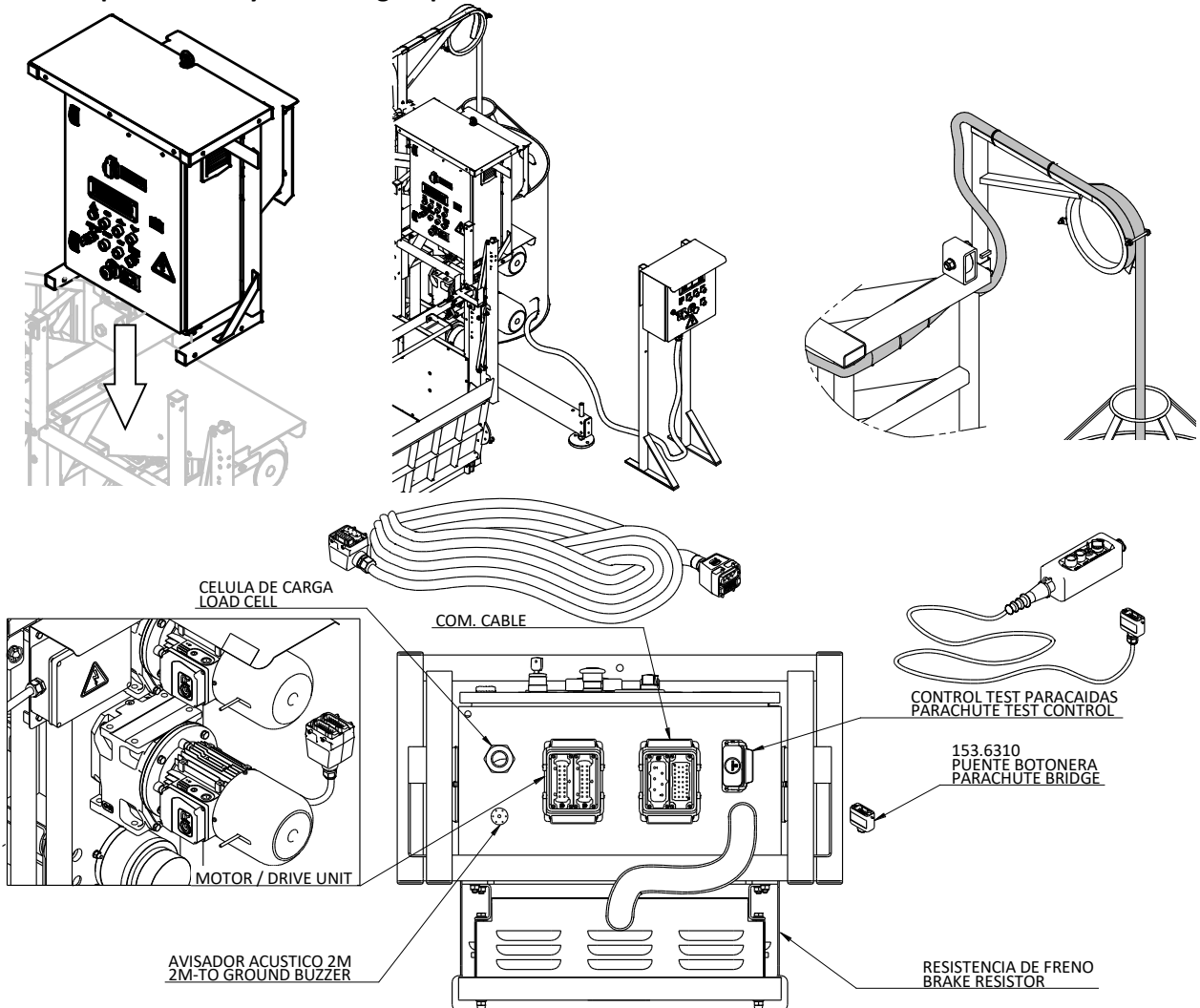
- Step 3. Assembly of motor group and electrical connection.

**ASSEMBLY OF ELECTRIC COMPONENTS AND CONNECTION**

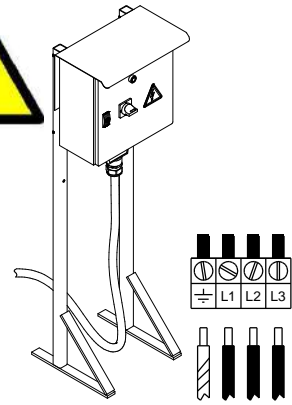
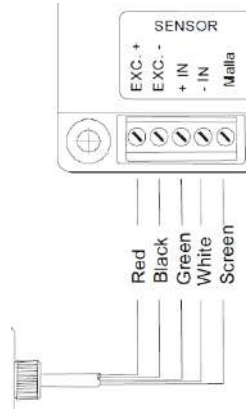
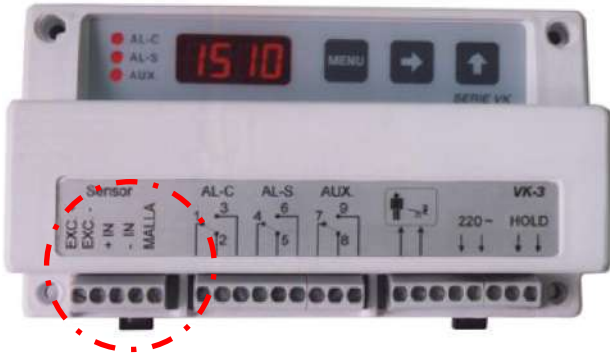

**CONNECTING LOAD CELL TO LOAD LIMITOR ON MAIN SWITCHBOARD**

**ELECTRIC SUPPLY**



**ATTENTION:**

**CONNECT ELECTRICAL EQUIPMENT TO MAIN SWITCHBOARD, WITH SPECIAL ATTENTION TO LOAD CELL CONNECTION TO THE PROGRAMER. PLEASE, CONSULT THE SPECIFIC INSTRUCTIONS FOR ADJUSTING THE LOAD DETECTOR PARAMETERS ON ANEX AT THE END OF THIS MANUAL.**

**ONCE THE BASE GROUP IS INSTALLED, ACCORDING WITH PREVIOUS INSTRUCTION HOIST CAN BE RUN UP FOR MAST COLUMN ERECTION.**

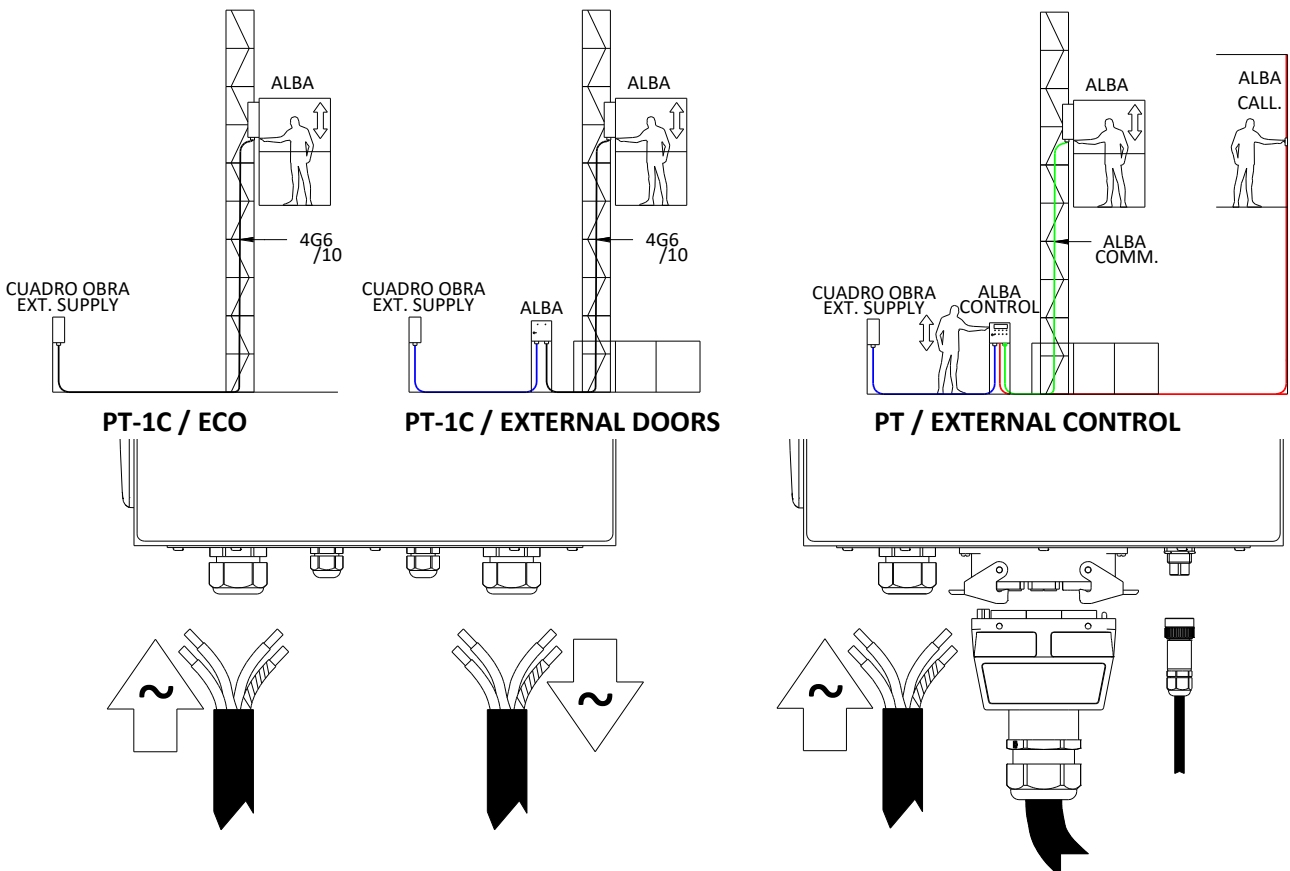

**GROUND PANEL POWER SUPPLY AND CONNECTION**

• Step 4. Erection of the mast.



**ATTENTION:**

TO ASSEMBLE THE MASTS WILL USE, PREFERABLY A BUILDING SITE CRANE, OR AN AUXILIARY DAVIT (OPTIONAL). NEVER MANIPULATE THE MASTS BY HAND. IT'S RECOMMENDED TO MOUNT SECTIONS OF 6 M. (4 MODULES) ON THE GROUND AND FASTEN THE WHOLE GROUP TO THE MACHINE WITH THE HELP OF A CRANE. THE FIRST MAST OF THE MACHINE, COUPLED TO THE BASE FRAME, INCLUDES THE NUMBER ID OF THE MACHINE.

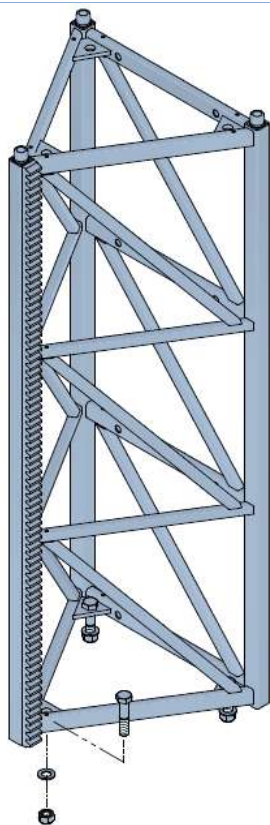

**MAST TÉCNICAL DATA**

**Weight:** 48 Kg

**Rack union:**

Welded

**Mast screws:**

(3x) Screw M20x90 DIN 931 8.8

Washer A21 DIN 125

Self-locking nut M20 DIN 985

**Torque (max):**

200 N·m



**IMPORTANT:**

TO MOUNT THE MACHINE, AND FOR INSPECTION AND MAINTENANCE TASKS, ALWAYS USE THE "MANUAL" MODE OF OPERATION (CAGE CONTROL). SEE CHAPTER 3 BEFORE STARTING HOIST ERECTION.  
 ii MAST ERECTION IN "AUTO" MODE IS NOT ALLOWED!

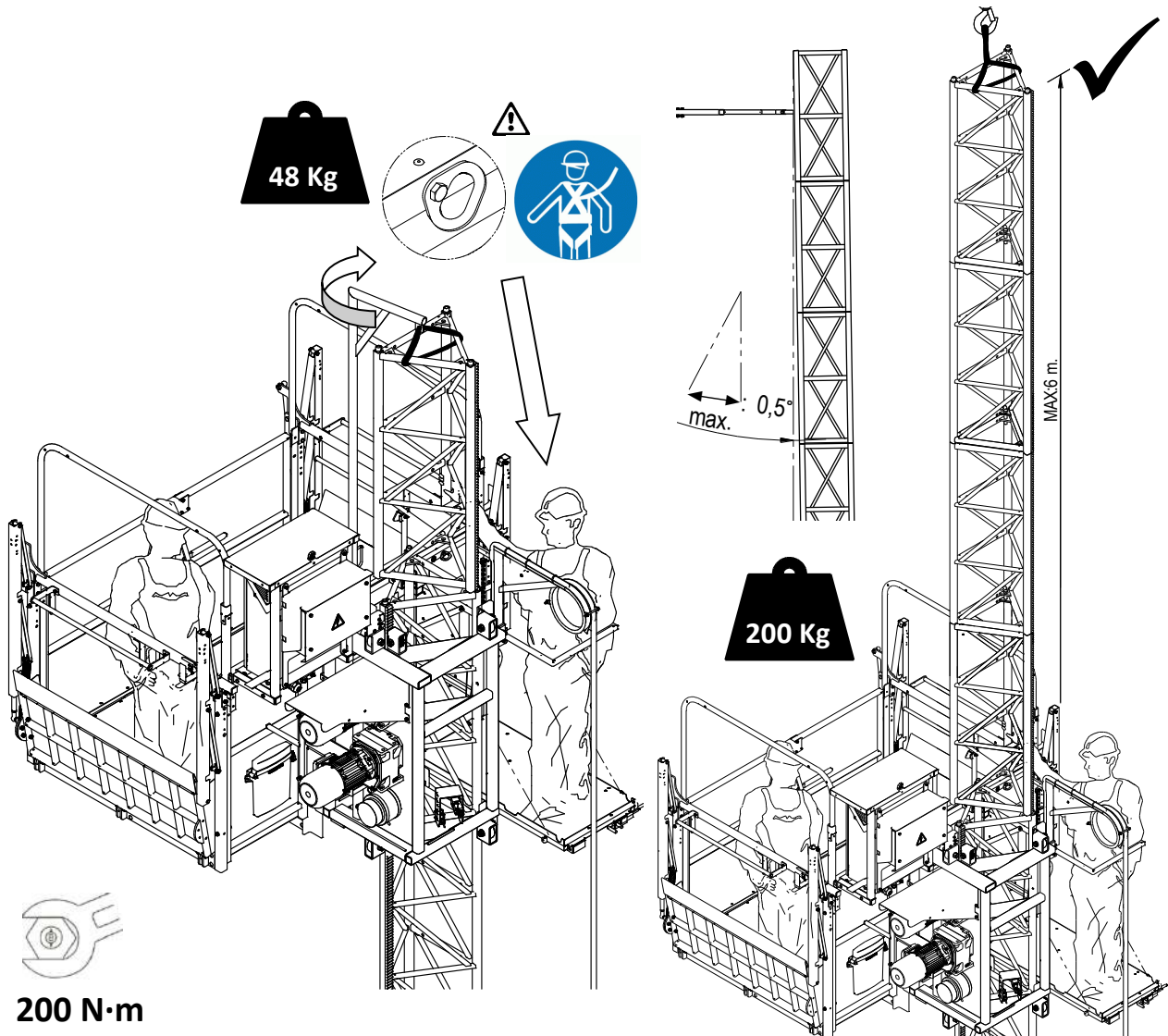

**MANUAL ASSEMBLY OF MASTS COLUMN**

**RECOMMENDATION. ASSEMBLY WITH CRANE**

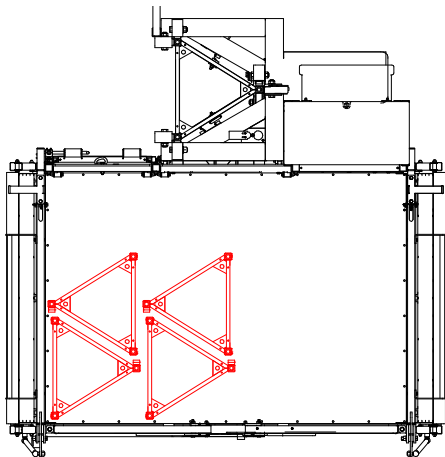

**TRANSPORT AND SUPPLY OF MAST INSIDE THE CAGE (SEE Step 14)**

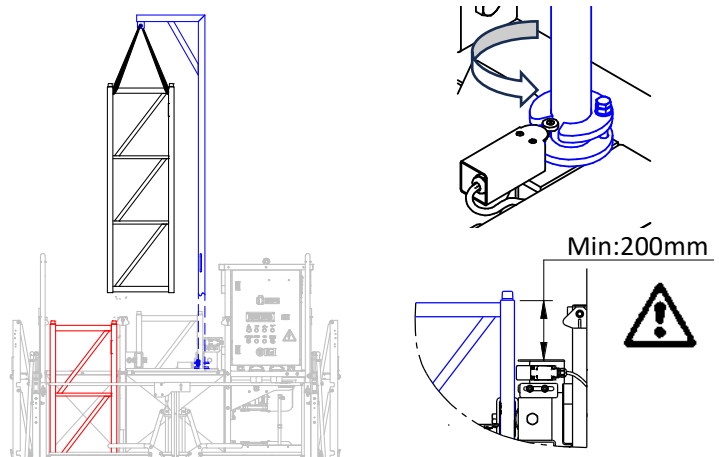

**ATTENTION:**  
**FIT / REMOVE MAST AND SCREWS ALWAYS AT THE SAME TIME!**  
**NEVER RAISE THE HOIST OVER A NON-SCREWED MAST MODULE!**  
**THEN THERE IS HAZARD OF COLLAPSE AND SERIOUS INJURY!**



**ATENCIÓN:**  
**IT IS IMPORTANT THAT THE BASE IS PERFECTLY LEVELED AND MAST CORRECTLY VERTICAL. ENSURE LEVELING TO AVOID FUTURE PROBLEMS.**

• Step 5. Installing mast anchorage.

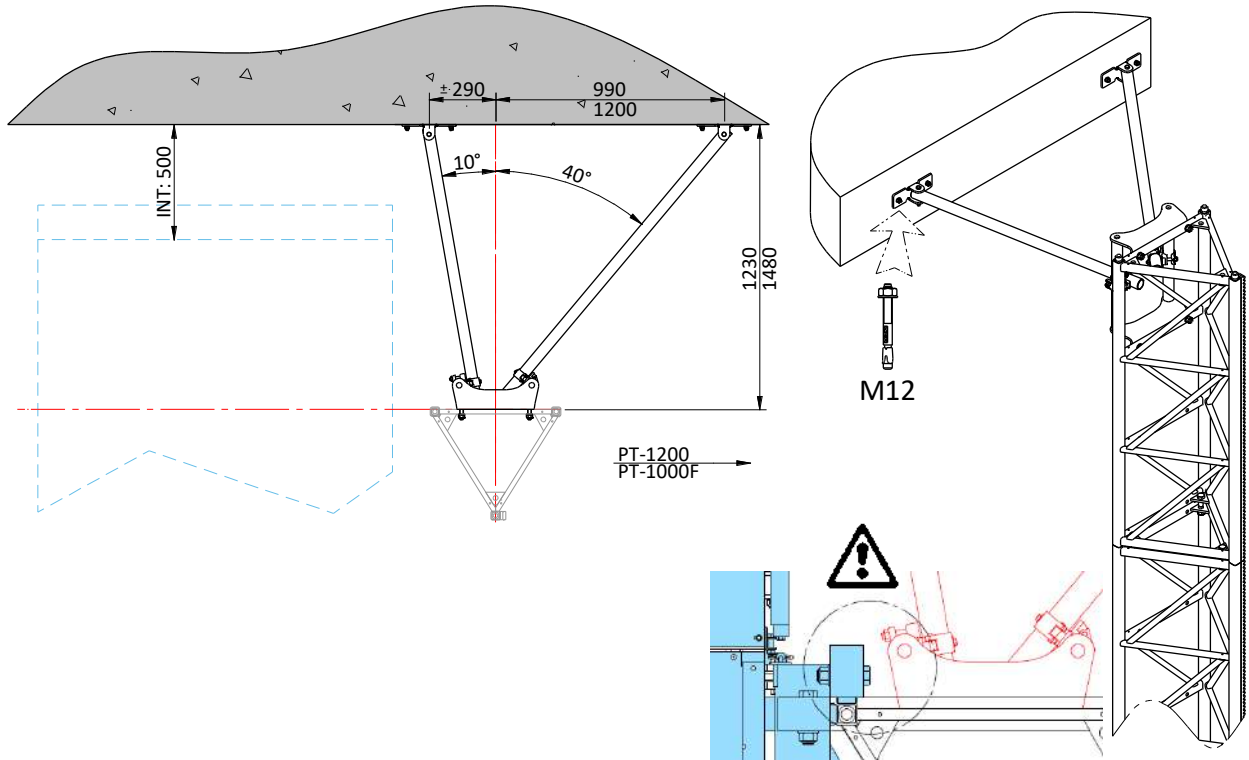

**ANCHORAGE ASSEMBLY. DIMMENSIONS. CHECKING INTERFERENCE**

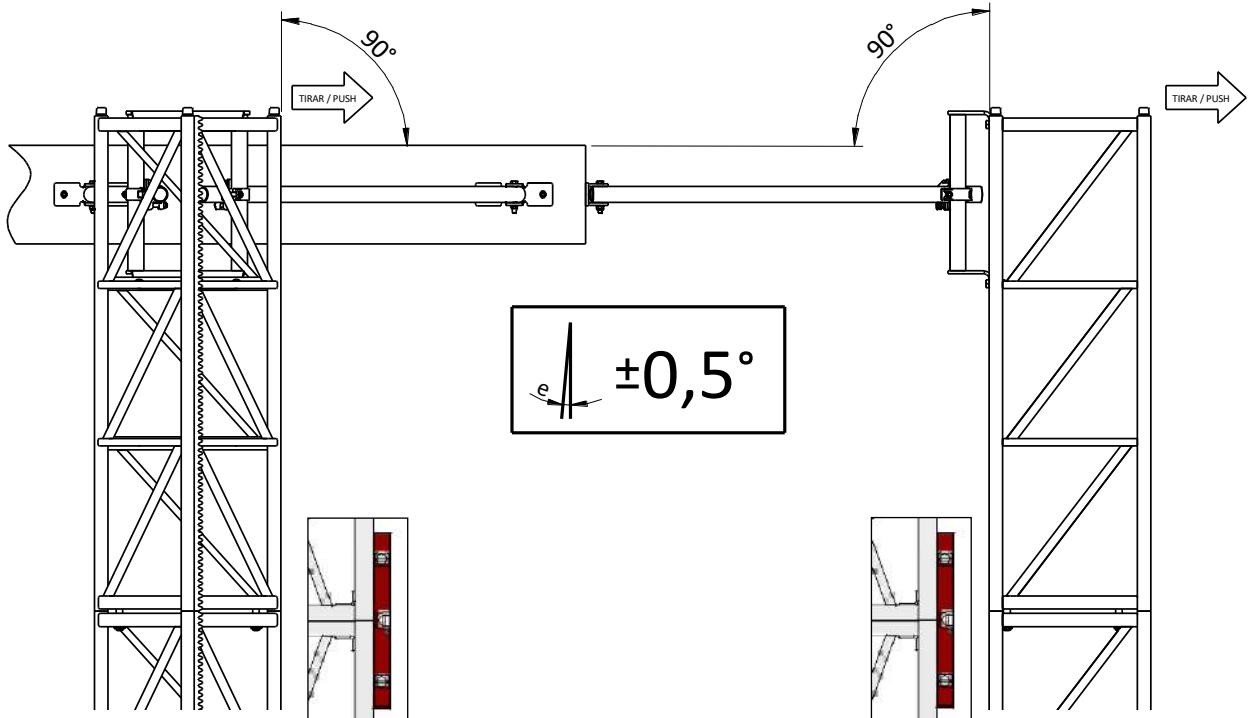

**FIXING TO THE SUPPORTING STRUCTURE**

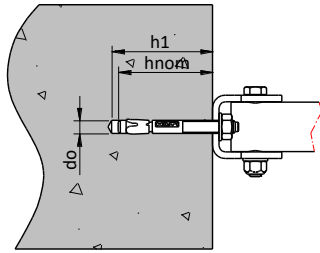

INSTAATION DATA		
D <sub>o</sub>	Drill diameter	12 mm
H <sub>1</sub>	Minimum drill depth	95 mm
H <sub>nom</sub>	Min. mounting depth	80 mm
L	Anchor length	120 mm
L <sub>r</sub>	Screw length	65 mm
D <sub>o</sub>	Torque	50 N·m

### RECOMMENDED ANCHORAGE SYSTEM

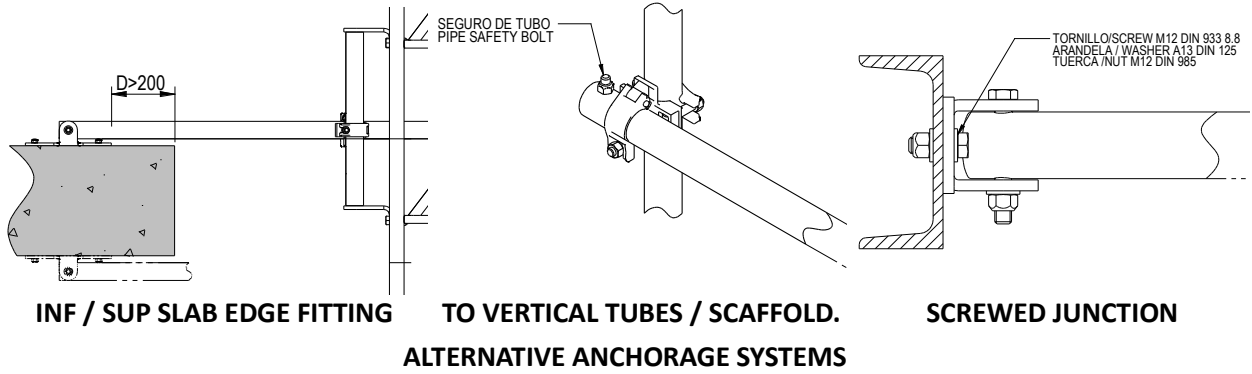

INF / SUP SLAB EDGE FITTING

TO VERTICAL TUBES / SCAFFOLD.

SCREWED JUNCTION

### ALTERNATIVE ANCHORAGE SYSTEMS

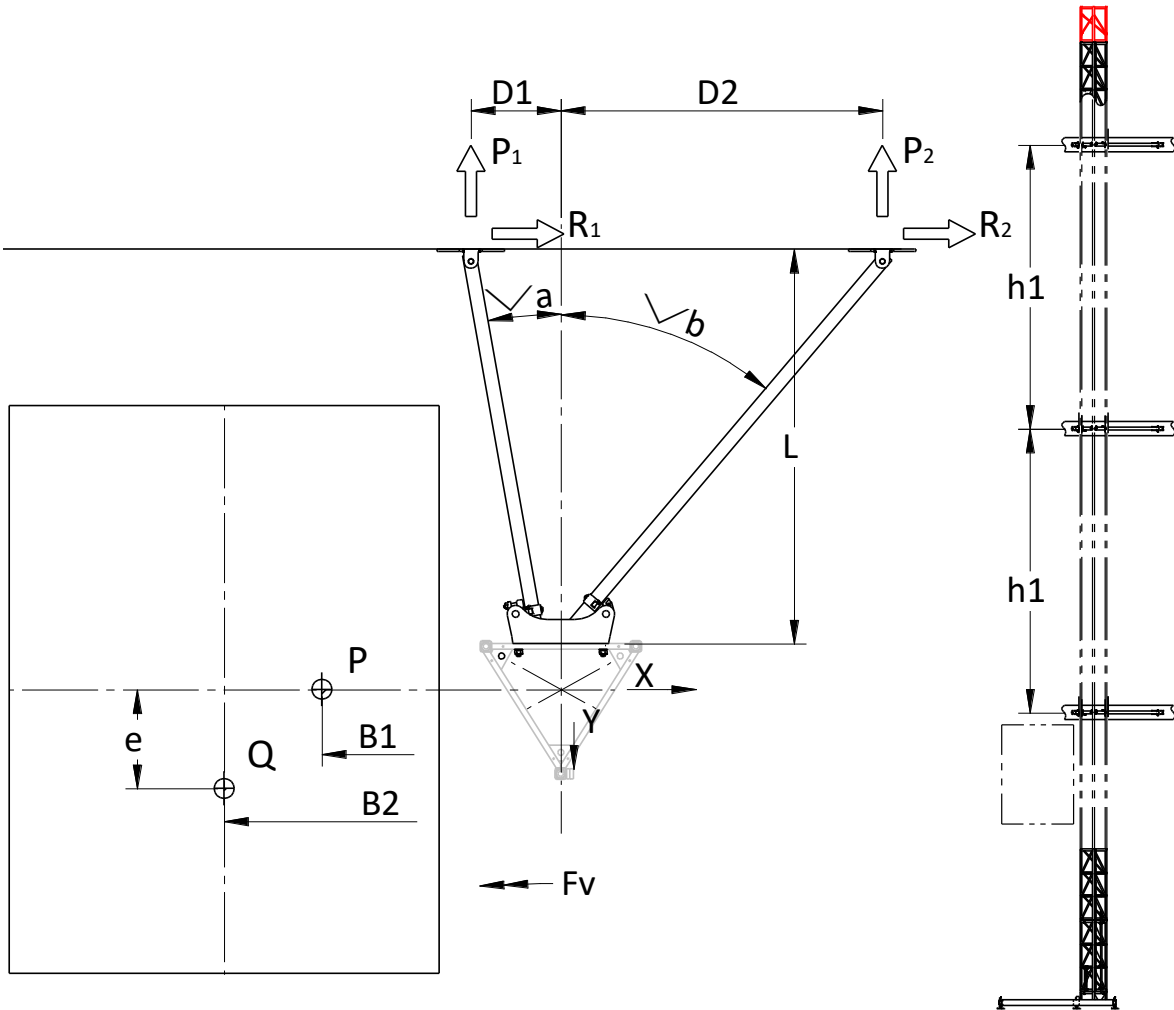
**REACTION FORCES TRANSMITTED TO STRUCTURE**

**INSTALLATION DATA**

DISTANCE TO ANCHOR POINT 1 (D1):	<b>250</b>	mm.
DISTANCE TO ANCHOR POINT 2 (D2):	<b>1.000</b>	mm.
HOIST TO FACADE DISTANCE (L):	<b>1.230</b>	mm.
SECONDARY ANCHORAGE ANGLE (Va): +	<b>10</b>	°
PRIMARY ANCHORAGE ANGLE (Vb): +	<b>36</b>	°

**REACTION FORCES**

P1:	<b>7,33</b>	KN.
P2:	<b>-5,74</b>	KN.
R1:	<b>1,49</b>	KN.
R2:	<b>4,67</b>	KN.

(x225) = [lbf]

**IMPORTANT:**

**TRANSMITTED FORCES TO THE STRUCTURE DECREASE WHEN INSTALLATION ANGLE AND DISTANDE "D" ARE INCREASED.**

**SEPARATE ANCHORAGE PLATES FROM EACH OTHER TO REDUCE TRANSMITTED LOADS TO STRUCTURE IF NECESSARY. CONSULT THE MANUFACTURER THE VALUES OF REACTIONS TO THE STRUCTURE RESULTING.**



**IMPORTANT:**

**TO TAKE INTO ACCOUNT THE EFFECT OF THE WIND IN SERVICE IN THE CALCULATION OF THE REACTIONS IN THE ANCHORS, TO THE VALUES OF REACTIONS RX, AND TO BE ADDED A FORCE Fv APPLIED MOST UNFAVORABLE DIRECTION (X)**

- Step 6. Installing end track cams and final mast.

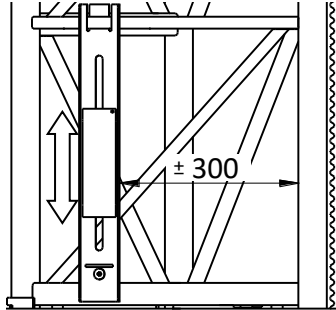

**ADJUSTING SUPERIOR ENDTRACK CAM**

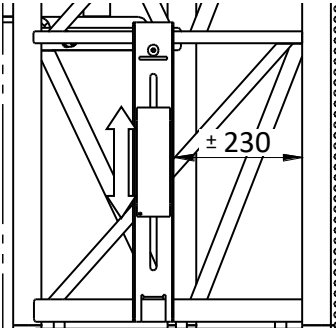

**ADJUSTING INFERIOR ENDTRACK CAM**

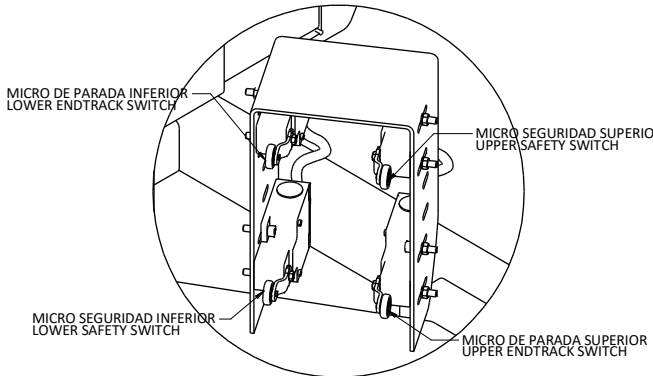

**ENDTRACK SWITCHES ON CHASSIS**

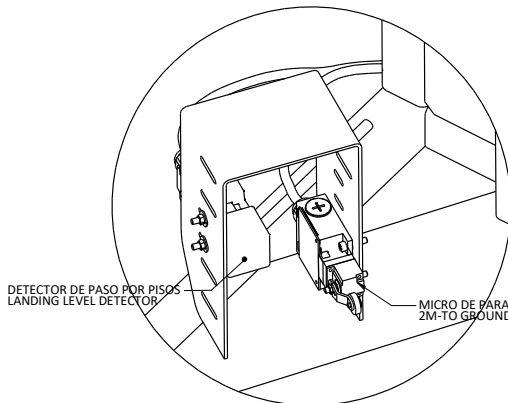

**LAST 2m SWITCH AND LANDING LEVELS DETECTOR**

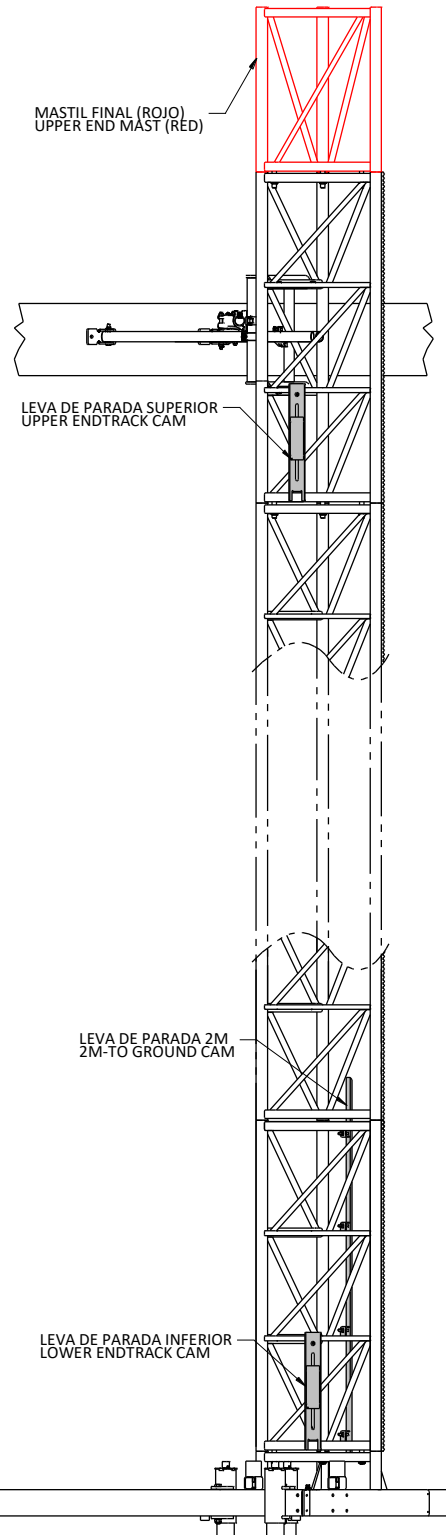

**ENDTRACK CAMS AND RED MAST POSITION**



**IMPORTANT:**

**INSTALL SUPERIOR ENDTRACK CAM ON THE LAST MAST AND THEN RED MAST WITHOUT RACK. USE VERTICAL REGULATION TO ACHIEVE BETTER STOP POINT.**

**CHECK IF HOIST STOP IS PROPERLY PERFORMED:**

- 1. RAISE ("MANUAL" MODE) UNTIL HOIST STOPS. CHECK THAT THE MACHINE STOPS WHEN F.C.S SWITCH TOUCH SUPEROR CAM, AND ALSO THAT RED MAST'S NOT REACHED.**
- 2. DESCEND ("MANUAL" MODE) UNTIL HOIST STOPS AND CHECK IF 2 m SWITCH HAS REACHED INFERIOR CAM. CHECK THAT LAST TRAVEL UNTIL Ref. Point ONLY CAN BE COMPLETED WITH "HOLD-TO-RUN" BUTTON OF CAGE CONTROL. CHECK IF THE MACHINE STOPS WHEN F.C.B SWITCH TOUCH INFERIOR CAM. (Ref. Point)**

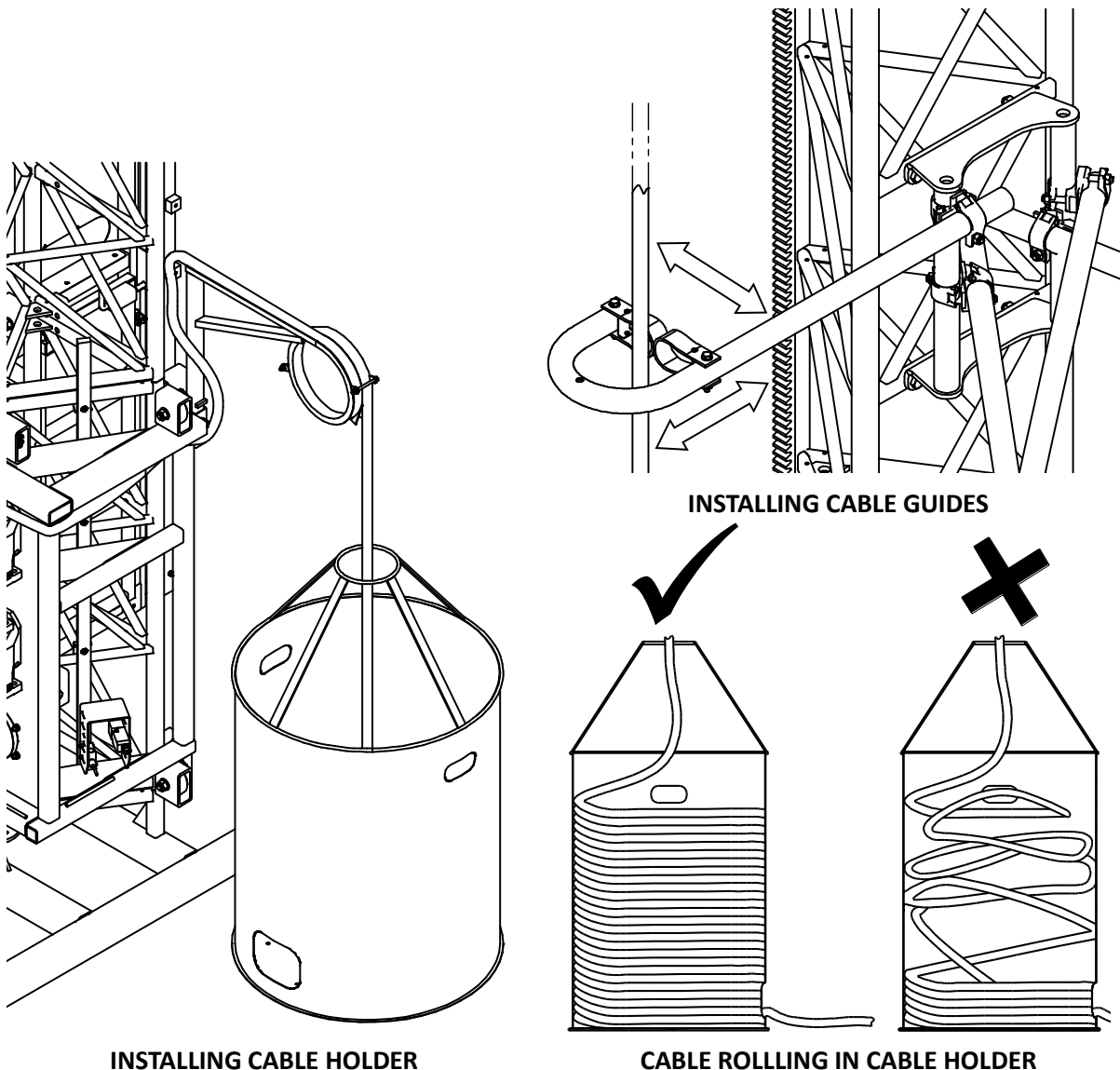
**THESE TESTS ARE VERY IMPORTANT BEFORE FURTHER ASSEMBLY!!**

**• Step 7. Installing cable holder.**

• Step 8. Installing base enclosure.



**ATTENTION:**  
**INSTALLATION OF A BASE ENCLOSEURE IS REQUIRED IN ACCORDANCE WITH HEREIN ESPECIFICATION OF EUROPEAN STANDARD EN 16719:2014**

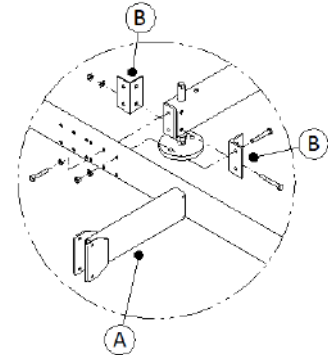
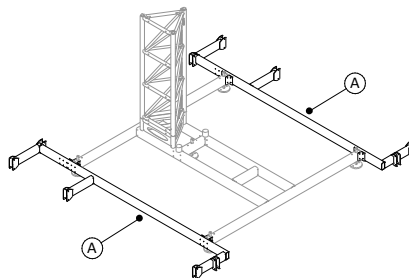
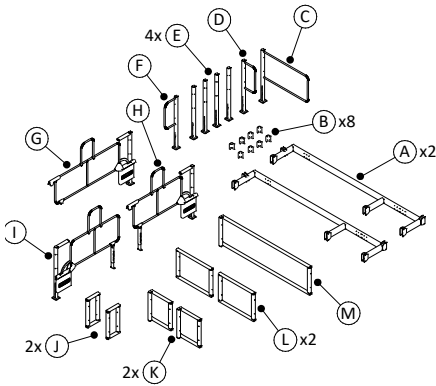

**BASE ENCLOSEURE ASSEMBLY**

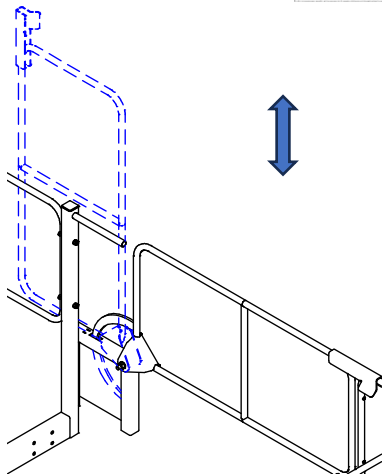
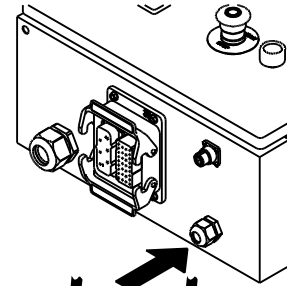
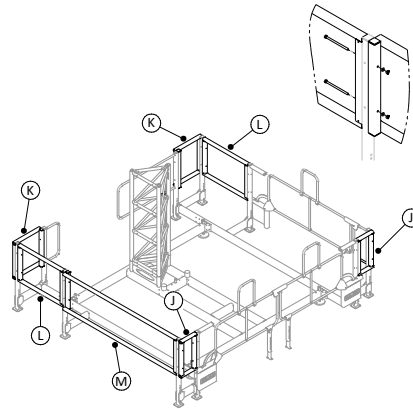
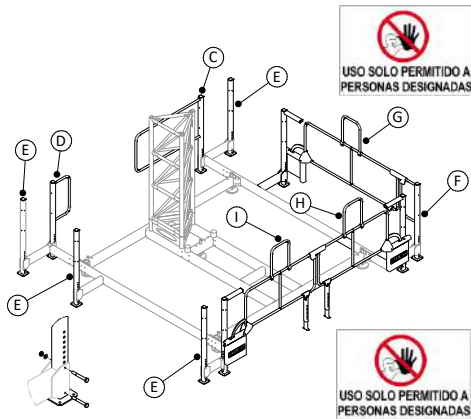

**ADJUSTING ENCLOSURE DOOR SWITCH**

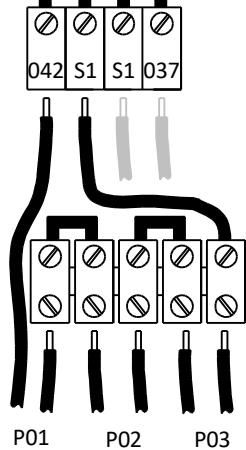

**DOORS SWITCH CONNECTION**



**ATTENTION:**  
**THE ENCLOSURE OF THE BASE ALLOWS A PERIMETER PROTECTION OF 500 mm. AROUND THE BASE OF THE MACHINE, TO PREVENT HAZARD OF SHEARING OR CUTTING WHEN HOIST IS MOVING**  
**IN NORMAL USE, DOWNWARDS MOVEMENT WILL BE STOPPED AT A HEIGHT OF 2 M ABOVE BASE. FURTHER DOWNWARDS MOVEMENT IS ONLY POSSIBLE BY NEW PERMANENT RESELECTION OFF "RUN" BUTTON.**

• Step 9. Installing landing doors.

• **SWINGING DOOR LANDING GATES (USUALLY TO SLAB):**

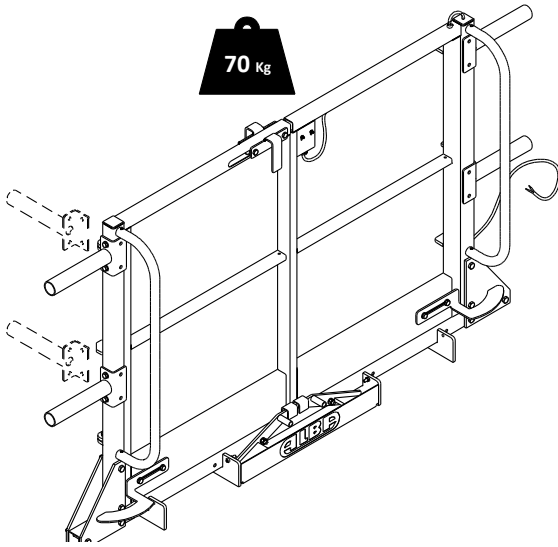

**163.5 SWINGING LANDING DOOR 1400**

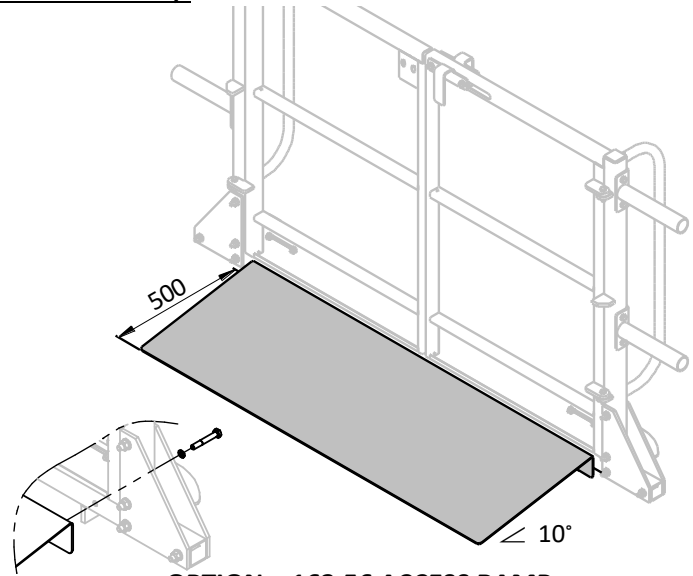

**OPTION – 163.56 ACCESS RAMP**

**INSTALLATION IN CONCRETE SLAB OR STRUCTURE**

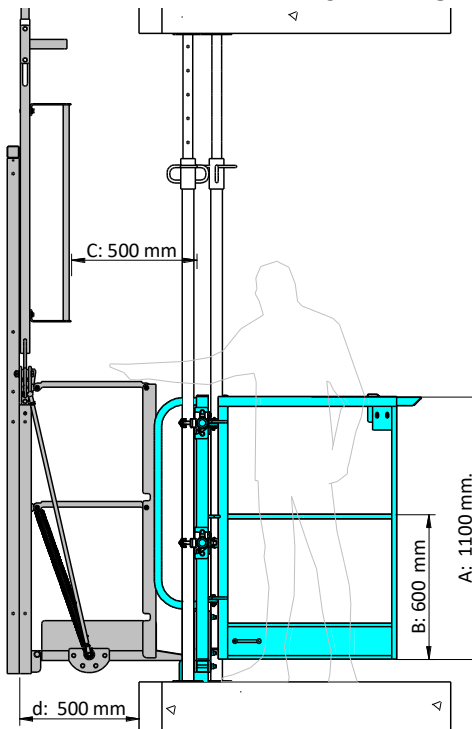

**INSTALLATION DISTANCES**

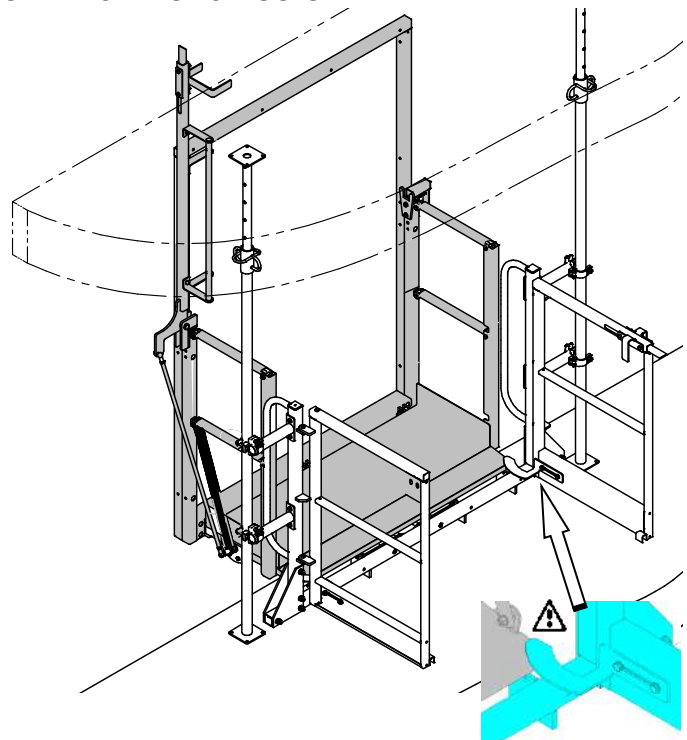

**ASSEMBLY DETAIL**

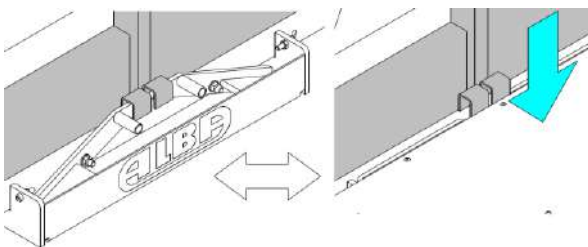

**UNLOCKING – OPENING LANDING DOOR**

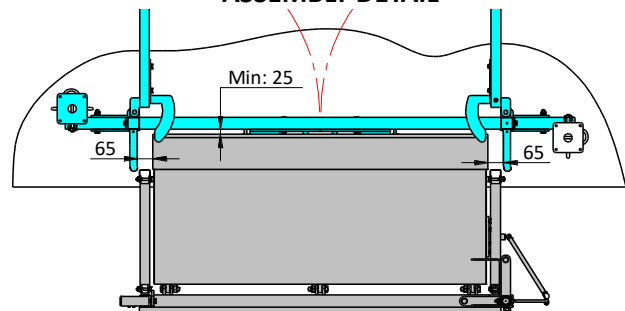

**DOOR ASSEMBLY ADJUSTMENT**

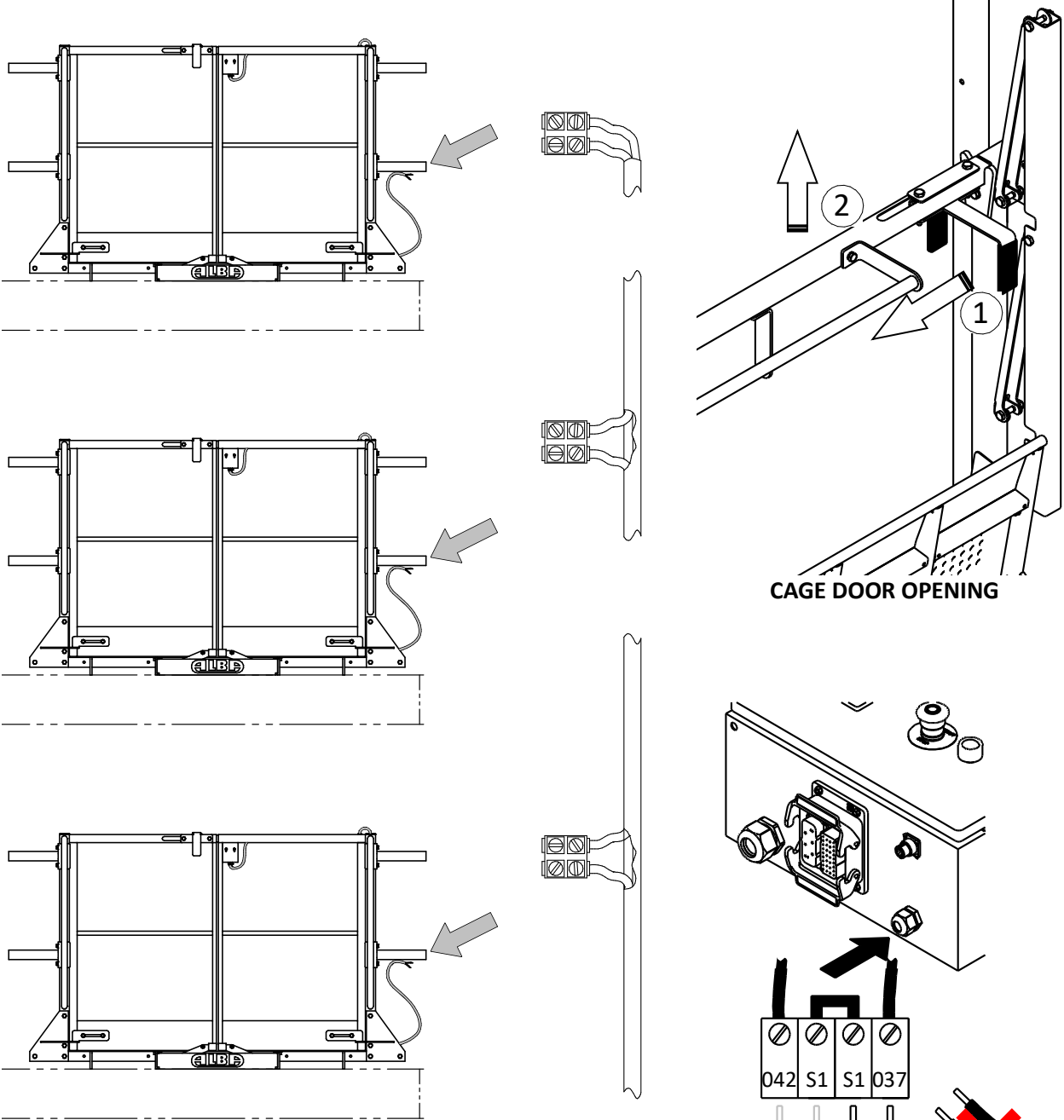

**CAGE DOOR OPENING**

**CONNECTION TO BASE PANEL**

**CONNECTION OF LANDING DOOR ELECTRICAL SWITCHES (S1-037)**

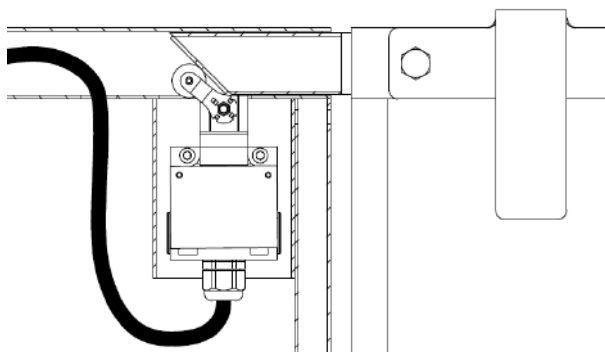

**ADJUSTMENT OF LANDING DOOR SWITCH**

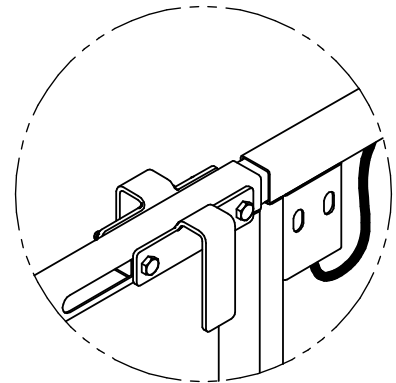

**LANDING DOOR LATCHING**

· **SLIDING DOOR LANDING GATES (USUALLY TO SCAFFOLD):**



**ATTENTION:**

**ADJUST DOOR POSITION SO THAT, WHEN CAGE RAMP IS DROPPED, LANDING DOOR INTERLOCK IS RELEASED AND DOOR CAN SLIDE TO OPEN.**

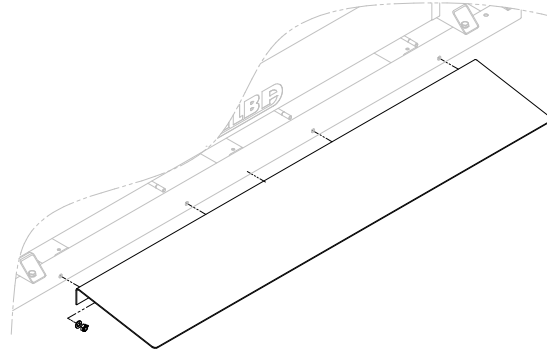
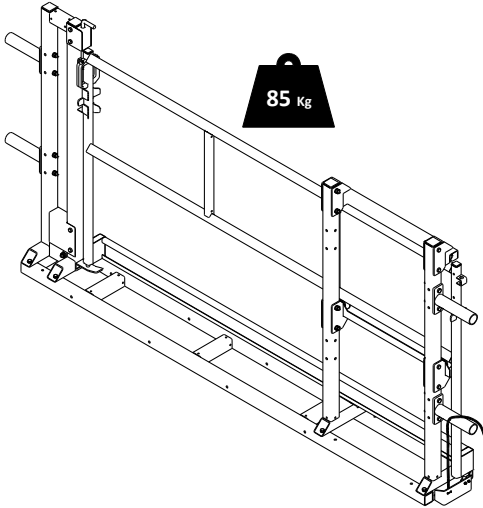

**161.5 SLIDING DOOR LANDING GATE 1400**

**OPTION – 161.56 ACCESS RAMP (∠ 10°)**

**INSTALLATION IN TO SCAFFOLD STRUCTURE**

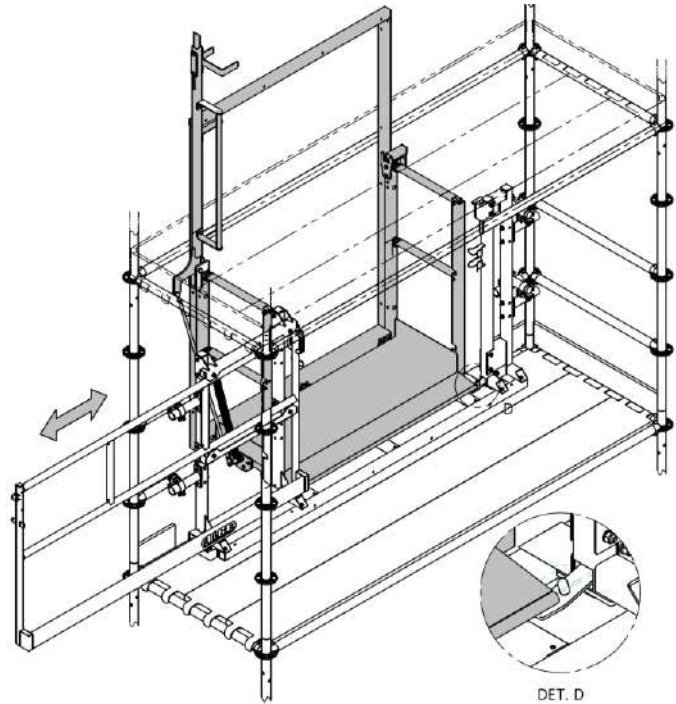
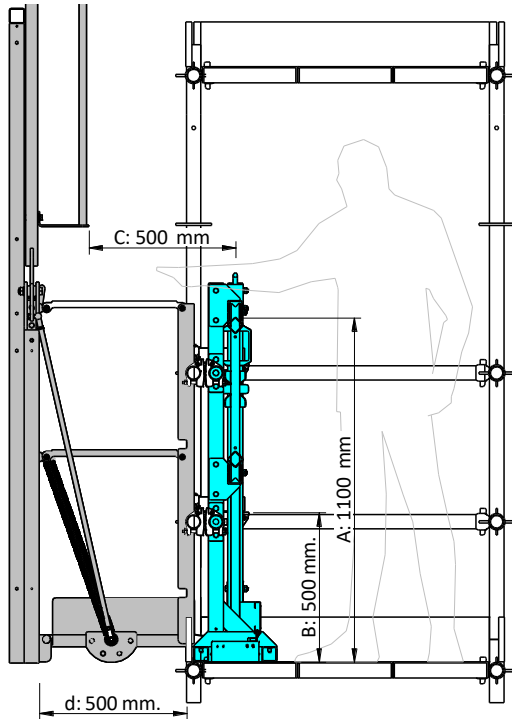

**INSTALLATION IN TO SCAFFOLD STRUCTURE**

**INSTALLATION IN TO SCAFFOLD STRUCTURE**

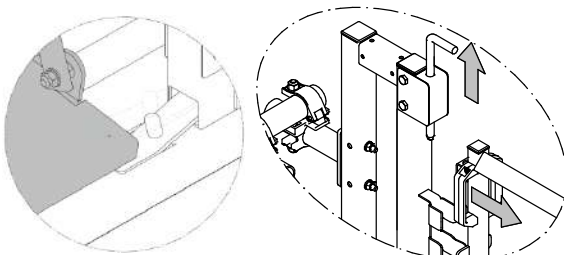

**UNLOCKING – OPENING LANDING DOOR**

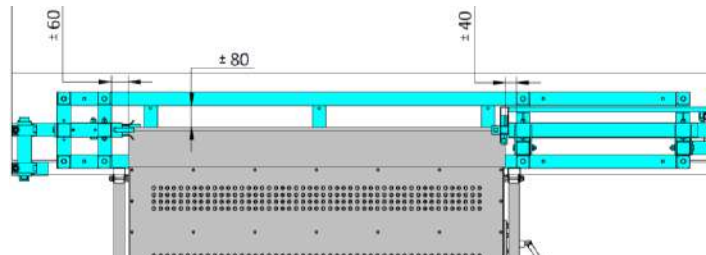

**DOOR ASSEMBLY ADJUSTMENT**

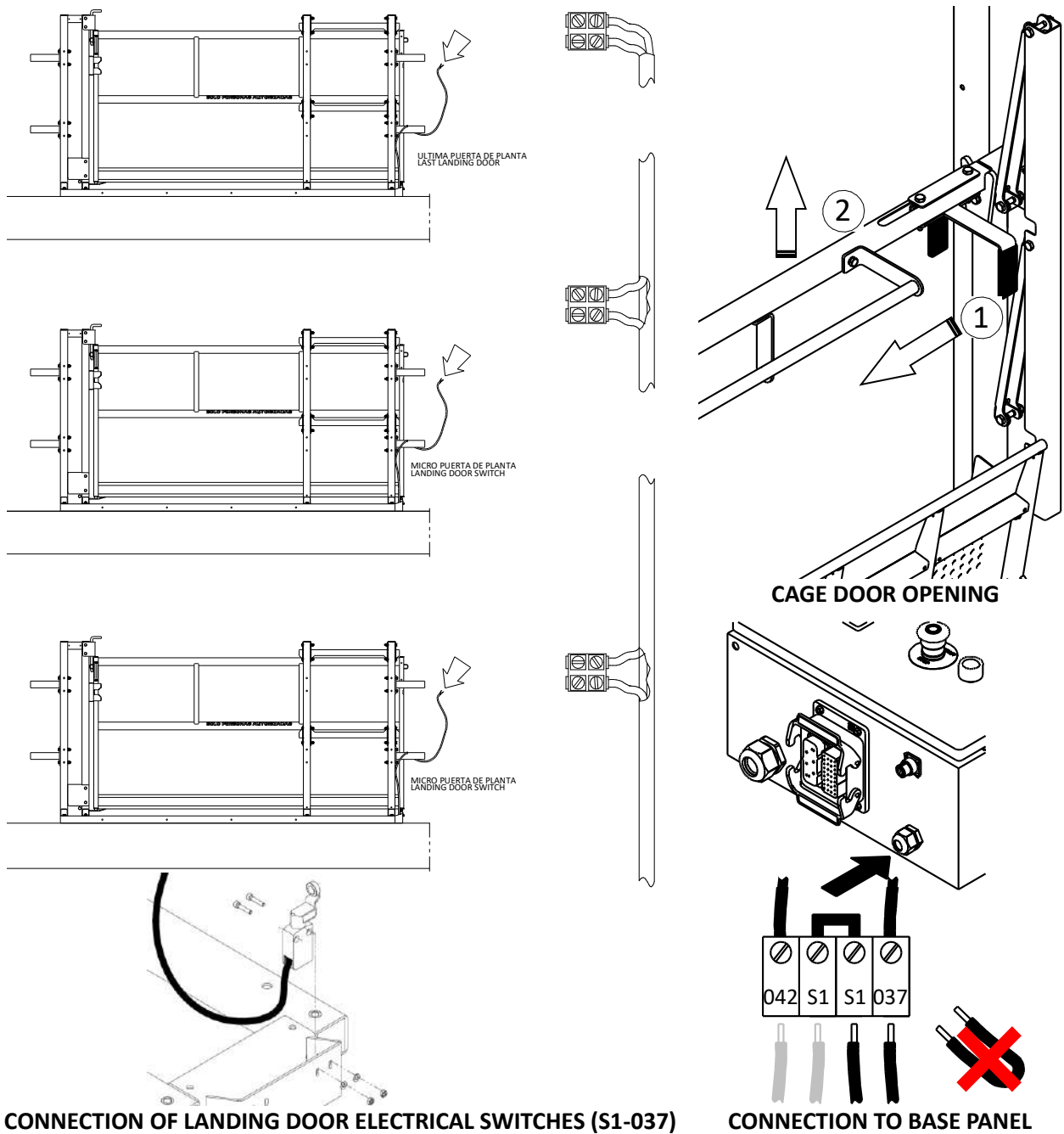

**IMPORTANT:**

ONCE THE DOOR MICROSWITCHES ARE INTER-CONNECTED, AND CONNECTED TO BASE CONTROL PANEL, IT'S NECESSARY THAT ALL DOOR ARE CLOSED TO MOVE THE PLATFORM.

MAKE SURE THAT THE CAGE DOORS ARE PROPERLY CLOSED AND LOCKED BEFORE MOVING THE HOIST.

• Step 10. Parachute testing.



**IMPORTANT:**

**AT THE END OF THE ASSEMBLY OF THE MACHINE, PRIOR TO USE, IT WILL BE MADE A TEST ON THE PARACHUTE**

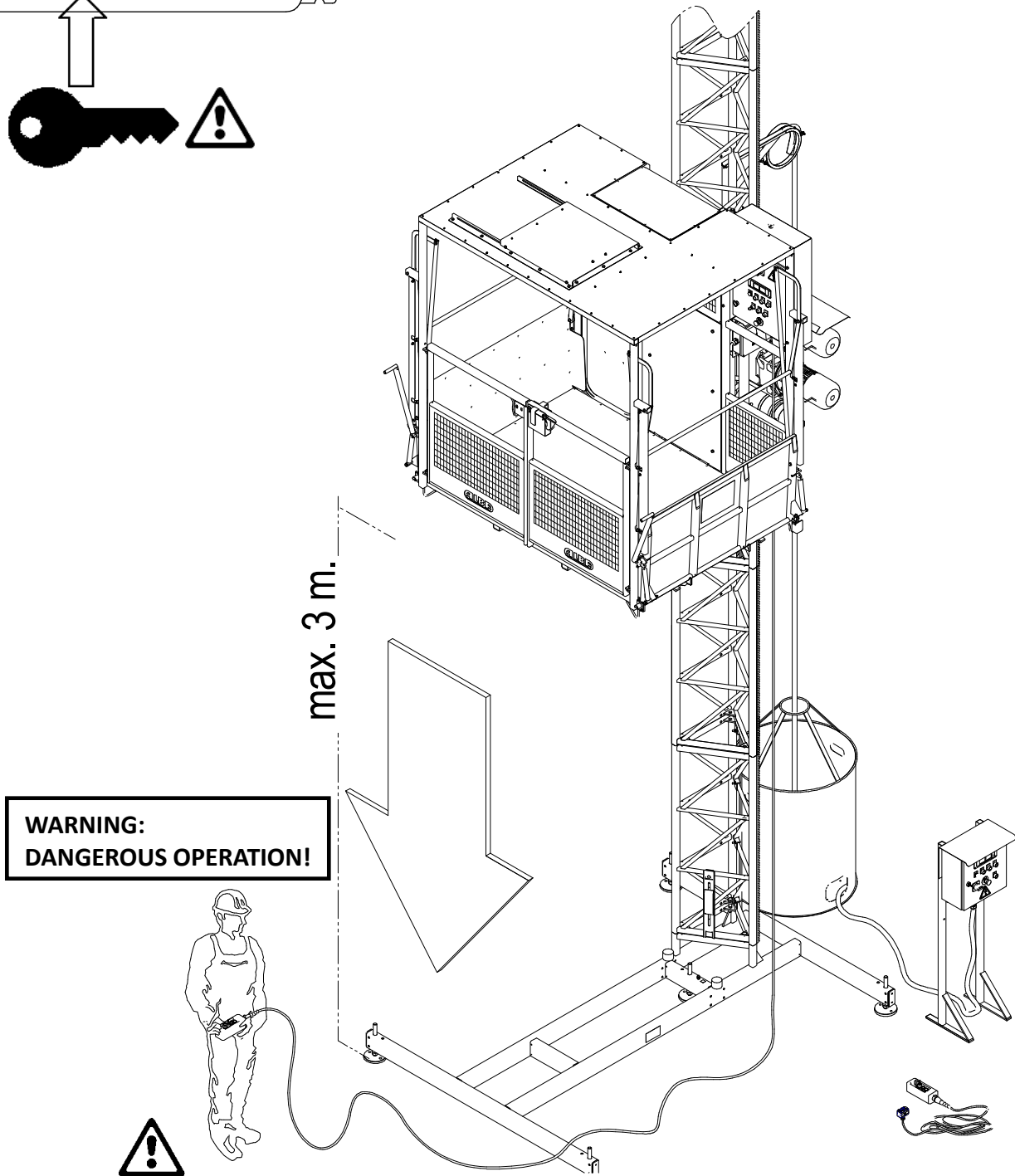
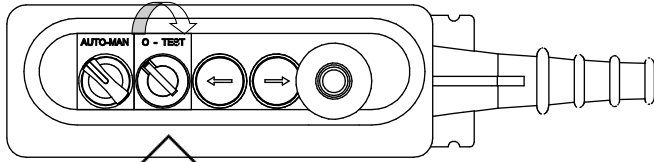

**PARACHUTE TEST PROCEDURE (Cap. 4)**

• Step 11. Installing landing level cams.



**ATTENTION:**

**BEFORE USING THE PLATFORM, IT IS NECESSARY TO INSTALL THE LANDING CAMS IN THE MAST AT DESIRED LANDING LEVELS.**

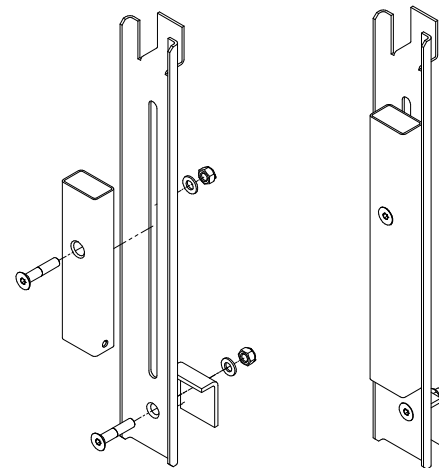
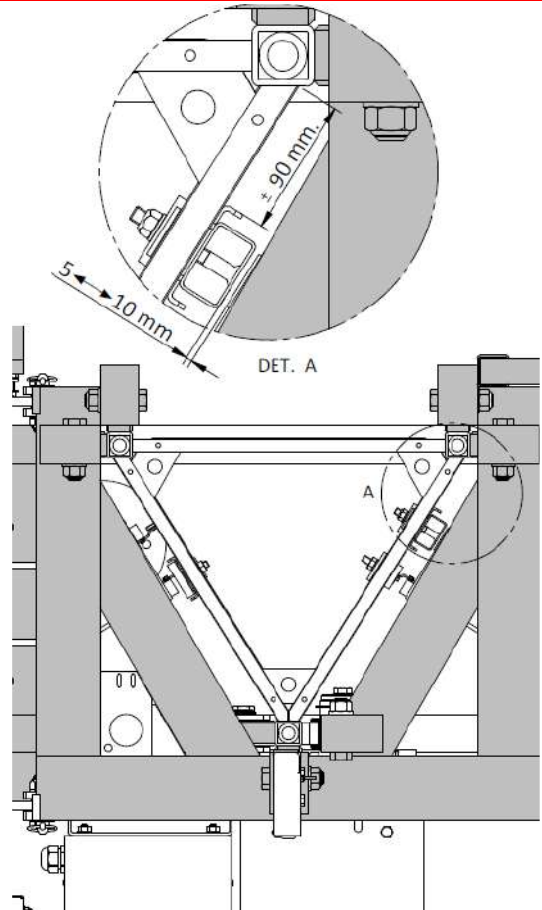
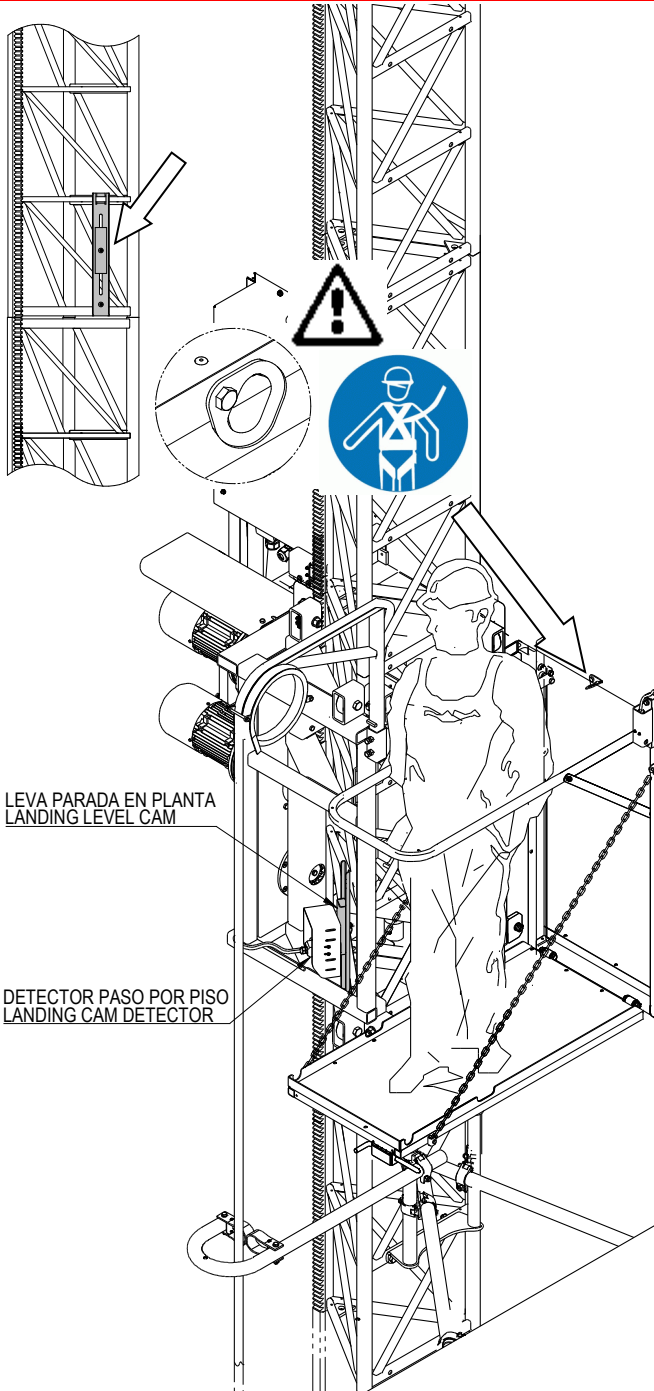

INSTALLING LANDING LEVELS CAM IN THE MAST

PT-1200-1V

PT-1200-2V



**IMPORTANT:**

**ONCE THE FLOOR CAMS ARE INSTALLED, MAX. NUMBER OF FLOOR IS TO BE PROGRAMMED IN THE CPU SYSTEM, SO THAT WAY, OPERATOR OF THE PLATFORM ONLY CAN SELECT ONE OF THE LANDING LEVELS PROGRAMMED.**

- Step 12. Programming landing levels.



**PROGRAMMING OPERATIONS ARE CARRIED OUT FROM THE CABIN SWITCHBOARD.  
IN EVERY NEW ASSEMBLY, OR IF THE ER E2 MESSAGE APPEARS, YOU MUST PROCEED REBOOT THE MEMORY OF THE CPU.**

### DELETE MEMORY / INITIALIZATION

- Step 1. Select MANUAL mode.
- Step 2. Place the elevator in the Reference Point (INFERIOR ENDTRACK LIMIT) (FCB).
- Step 3. Process:

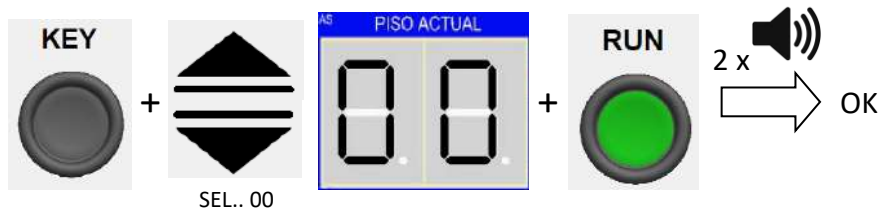

- Step 4. Release KEY: 1 x INITIALIZATION.  
OK

### MAXIMUM FLOOR PROGRAMMING



**ATTENTION:  
THE CONTROL ALLOWS TO MEMORIZE THE NUMBER OF FLOORS THAT HAVE BEEN INSTALLED, TO PREVENT THAT A FLOOR BE SELECTED IN OPERATION ABOVE THE LAST INSTALLED CAM.**

- Step 1. Select MANUAL mode.
- Step 2. Press up from the cabin control until you leave the Reference point FCB (a few cm.)
- Step 3. Process:

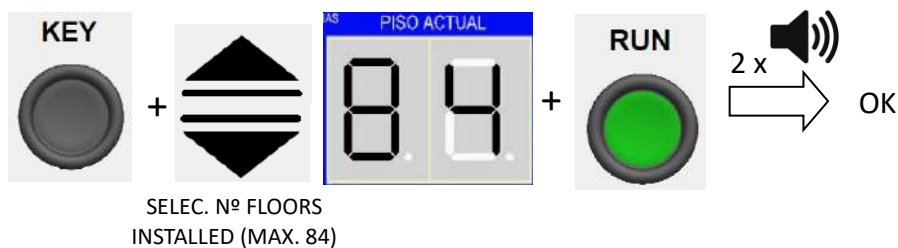

- Step 4. Release KEY. 1 x MEMO Nº MAX. FLOORS OK



**IMPORTANT:  
AFTER SAVING MAXIMUM NUMBER OF FLOORS, THE HOIST MUST BE DOWN TO FCB IN "MANUAL" MODE. AFTER CHANGING TO "AUTO" MODE YOU WILL BE ABLE TO START WORKING.**

## NEGATIVE FLOORS



### IMPORTANT:

THE HOIST ALLOWS TO DISPLAY NEGATIVE FLOORS. DEFINING NEGATIVE FLOORS DISPLACES REF. POINT TO THE LOWEST POINT OF THE ROUTE. NEGATIVE FLOORS ONLY AFFECT THE DATA SHOWN ON THE DISPLAY.

- Step 1. Select MANUAL mode.
- Step 2. Place the hoist in reference point FCB
- Step 3. Process:

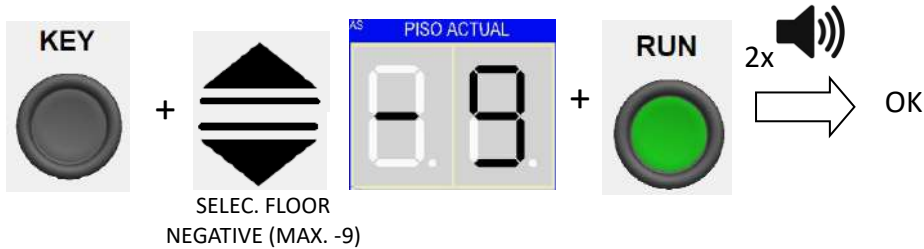

- Step 4. Release KEY 1 x MEMO NEW REFERENCE POINT IN NEGATIVE FLOOR



### IMPORTANT:

WHEN DEFINING NEGATIVE FLOORS, REFERENCE POINT IS DEFINED ON THE LOWER FLOOR. WHEN PROGRAMMING MAX. NUMBER OF FLOORS MUST BE TAKEN INTO ACCOUNT OF NEGATIVE FLOORS.

Example: PTO. REF.: -5, P.MAX: 15" THE DISPLAY SHOWS ONLY: -5 ÷ 10

- Step 13. Installing landing levels call system – OPTION.



### ATTENTION:

CALLING THE HOIST FROM THE FLOORS WILL ONLY BE POSSIBLE WHEN THE HOIST IS FREE (GREEN PILOT OFF).

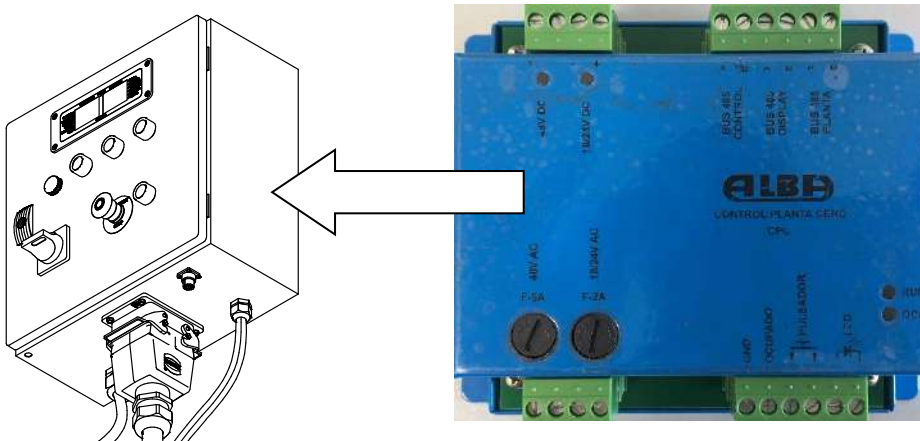

E-CPC-A CARD FOR FLOOR CALLS MANAGEMENT ON INFERIOR CONTROL BOARD

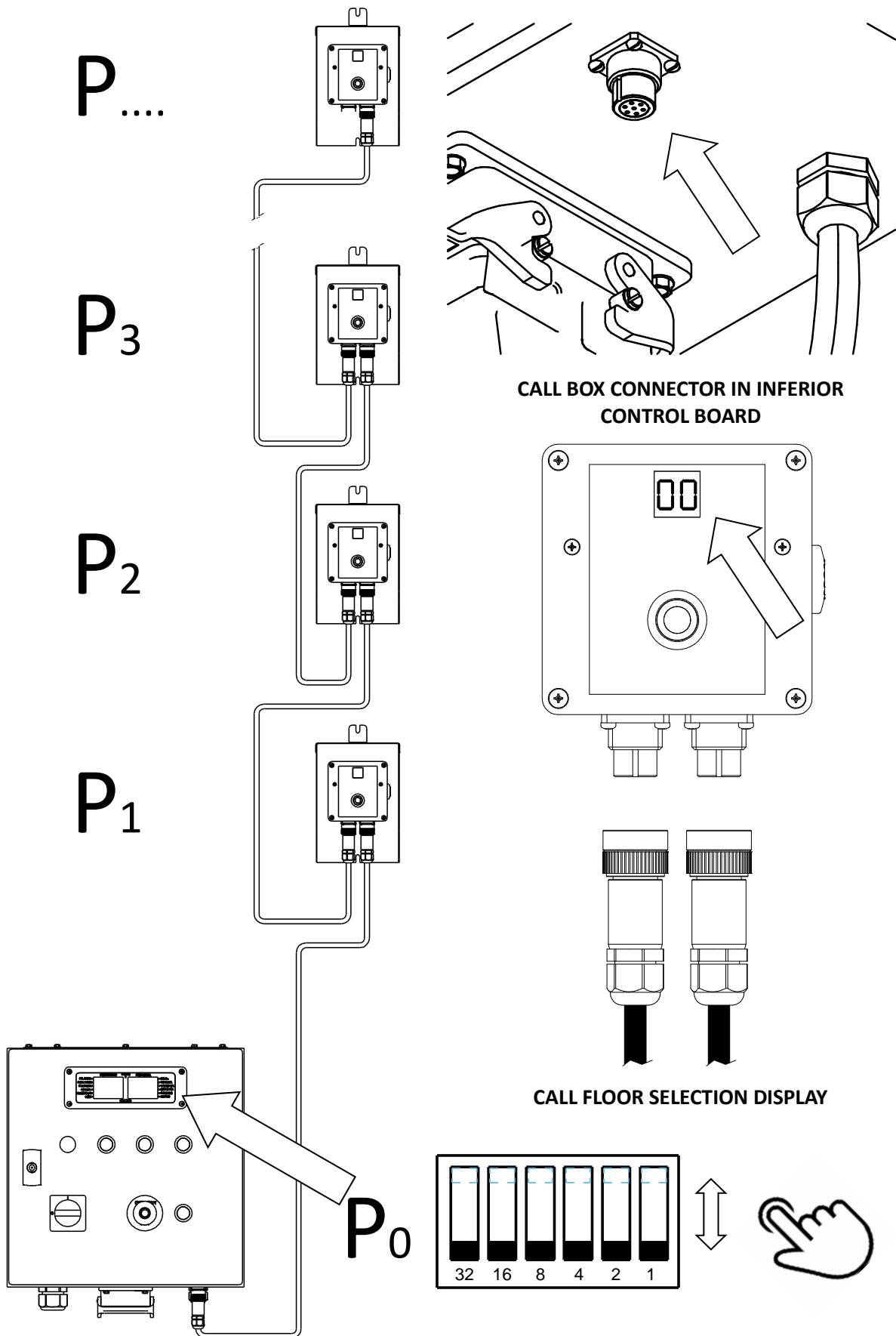

**INSTALLATION OF FLOOR CALL BOXES**

**SELECTING THE CALL FLOOR (BINARY CODE)**

• Step 14. Installing aux. crane for mast erection – OPTION

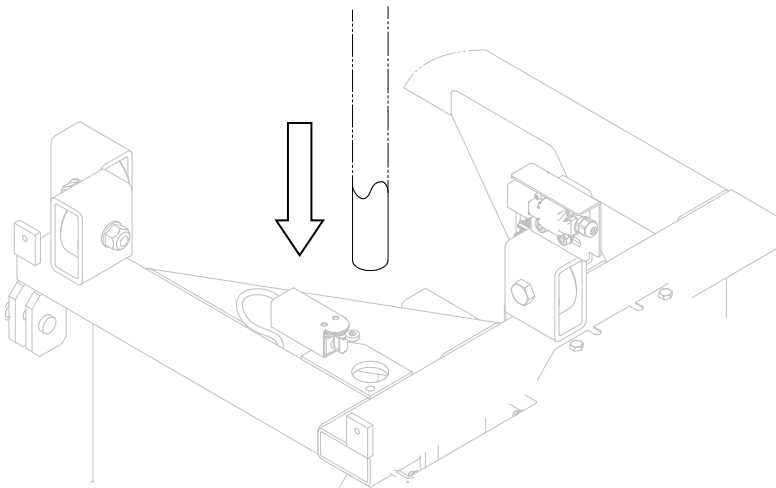

CRANE FITTING TO CHASSIS

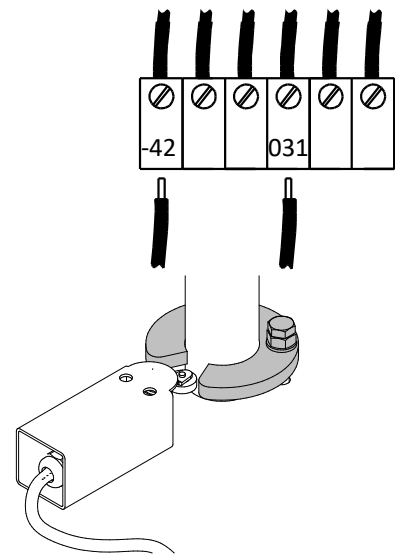

CRANE POSITION SWITCH  
AND ELECTRIC CONNECTION

• Step 15. Assembly of roof and mast protector.

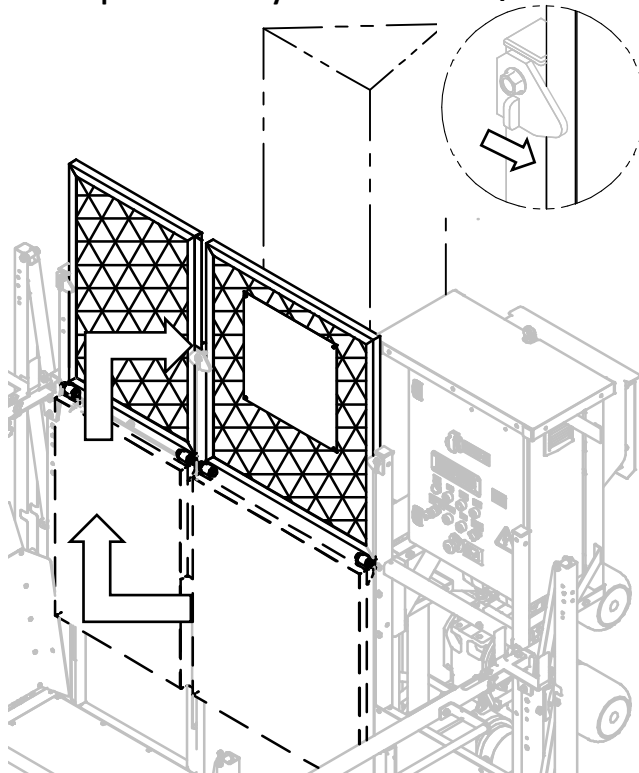

ASSEMBLY OF MAST PROTECTOR

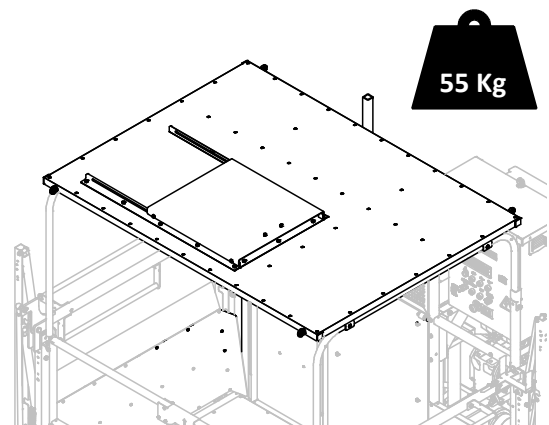

ASSEMBLY OF ROOF FOR FALLING OBJETS



**ATTENTION:**

**UPON COMPLETION OF ASSEMBLY, THE MAST GUARD MUST BE FIXED IN POSITION BEFORE THE PLATFORM IS COMMISSIONED FOR THE USERS.**

**SEE CONDITIONS OF USE OF THE TRANSPORT PLATFORM WITH PROTECTIVE ROOF ACORDING TO REGULATIONS. (SEE Page 12)**

## 2.4. Dismantling the hoist

For the dismantling of elevator perform the reverse process to that described in this manual, with particular attention to the tasks that present a risk of falling.



**ATTENTION:**  
**FOR MACHINE DISMANTLING “MANUAL” MODE IS TO BE USED, WITHOUT LOADS, AND OPERATING THE HOIST FROM CAGE CONTROL.**

Step 1. Dismantling mast column and anchorages

Remove first the red Mast and upper stop cam and then the column of masts and anchors. For that, you can remove the platform falling objects protector ceiling and folding the mast protector.



**ATTENTION:**  
**REMOVE MAST AND SCREWS ALWAYS AT THE SAME TIME!**  
**NEVER RAISE THE HOIST OVER A NON-SCREWED MAST MODULE!**  
**THEN THERE IS HIGH CHANCE OF COLLAPSE AND SERIOUS INJURY!**



Step 2. Dismantling cable system and guides

Remove the cable bracket and remove the cable guides, continuing with the dismantling of the mast column to the lower limit.

Step 3. Electrical devices disconnecting

Once you reach the lower limit, disconnect the power supply and remove electrical equipment.

Step 4. Dismantling the cage

Remove the cage by releasing union bolts, by the same procedures described for mounting.

Step 5. Dismantling base frame

Release buffers, remove anchorage to ground. The hoist is ready for transport.



**ATTENTION:**  
**IMPORTANT NOTE ON COMPLIANCE WITH EUROPEAN DIRECTIVE 2006/42/CE.**

CE DECLARATION OF CONFORMITY is valid only for machines purchased and installed with all original components supplied by CANOPY BRANDS EUROPE, S.L.U. and following all the instructions provided in this user's manual, ensuring compliance with all SSER Annex I of Directive 2006/42/EC.

Otherwise, the machine can't be put into service until final assembly is declared in accordance with the specifications of Annex II of the Directive.

### 3. USING THE MACHINE.

#### 3.1. Introduction.



**WARNING:**  
HOIST CAN ONLY BE USED BY THE DESIGNATED PERSONS, WHO HAVE BEEN INSTRUCTED IN THE SAFELY HOIST OPERATION

ACCESS TO THE PLATFORM FOR LOAD AND UNLOAD ONLY IS ALLOWED FOR TRAINED PERSONS

FIT THE LOAD CONVENIENTLY INSIDE THE CAGE, ESPECIALLY IF IS TRANSPORTED WITH PEOPLE TRAVELING TOGETHER.



**IMPORTANT:**  
TWO OPERATION MODE ARE POSSIBLE WITH THE HOIST:



- "MANUAL" MODE (ONLY FOR ASSEMBLY): HOIST MOVEMENTS ARE PERFORMED WITH HOLD-TO-RUN BUTTONS. CONTROL IS ALLOWED ONLY FROM THE CAGE CONTROL (▲ ▼).
- KEEP THE KEY FOR "MANUAL" MODE SWITCH OUT OF THE REACH OF ELEVATOR USERS.



- "AUTO" MODE: THE MACHINE IS USED BOTH FROM THE CONTROL ON THE FLOOR (ONLY LOADS), AND FROM THE CAGE CONTROL (PERSONS AND LOADS). THE MACHINE IS MOVING ON PROGRAMED LANDING LEVELS. (SEE LANDING LEVELS PROGRAMMING)



- HOIST ALLOWS (AS AN OPTION) A LANDING LEVELS CALLING CONTROL SYSTEM).



**ATTENTION:**  
DUE TO SAFETY PURPOSES, WHEN DESCENDING, HOIST STOPS WHEN IT REACH 2M REMAINING TRACK UNTILL INFERIOR ENDTRACK LIMIT IS ONLY TO BE POSSIBLE BY HOLDING "RUN" BUTTON.

PT-1200/1000F-2V: IN "PERSONS" MODE, THE CONTROL HAS A DELAY OF 3 SEC. TO COMPLETE DOWNWARDS MOVEMENT OF 2M ZONE.



**WARNING:**  
"MANUAL" MODE ONLY IS ALLOWED FOR AUTHORIZED AND COMPETENT TECHNICAL PERSONS, WHO WILL KEEP THE KEY TO PREVENT USE BY UNAUTHORIZED PERSONNEL.

3.2. Using "MANUAL" mode.



**WARNING:**  
**"MANUAL" MODE IS USED FOR HOIST ASSEMBLY / DISMANTLING TASKS, AND FOR INSPECTION AND MAINTENANCE.**  
**HOIST HANDLING IS PERFORMED ONLY FROM THE CAGE CONTROL.**  
**OPERATE THE PLATFORM IN "MANUAL" MODE IS FORBIDDEN BY UNAUTHORIZED USERS.**

**MAKE SURE THE CAGE DOORS ARE PROPERLY CLOSED AND LOCKED BEFORE MAKING ANY MOVEMENT WITH THE PLATFORM.**

A) Transport platform PT-1200/1000F-2V:

**DESCRIPTION OF THE CONTROLS - MANUAL MODE**

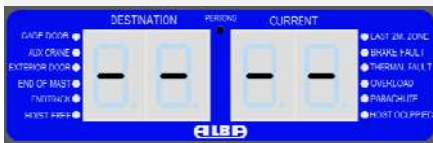

**MANUAL MODE ACTIVE**



**LIGHT - OUT OF SERVICE**

**START EQUIPMENT RESET BUTTON**

**AUTO-MAN**



**MANUAL MODE SELECTOR**



**SELECTOR NOT ENABLED**

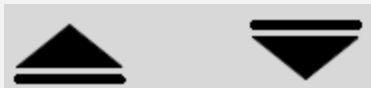

**UP - DOWNLOAD MANUAL**

**KEY**

**PROGRAMMING BUTTON**

**RUN**

**LOWERING MANUAL - ZONE 2 m.**

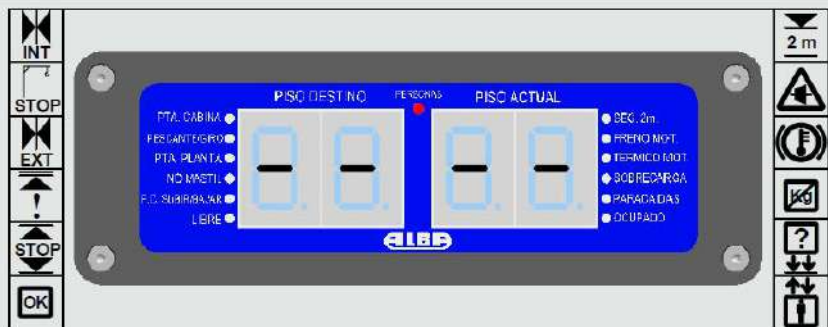

**RUN**



**AUTO-MAN**



**START**



**KEY**

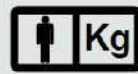

**ATTENTION:**



**ALL MOVEMENTS IN CASE OF USE OF THE MANUAL MODE WILL BE WITH THE CONTROL UP - DOWN PUSHING CONTINUOUSLY AND WITH SLOW SPEED.**

**B) Transport platform PT-1200/1000F-1V:**

**DESCRIPTION OF THE CONTROLS - MANUAL MODE**



**MANUAL MODE ACTIVE**



**LIGHT - OUT OF SERVICE**

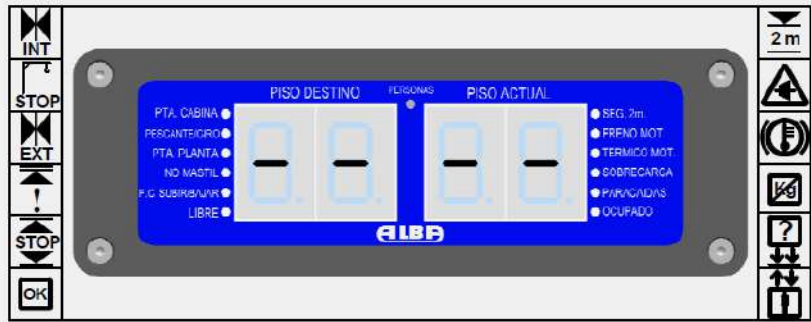

**START**

**EQUIPMENT RESET BUTTON**

**AUTO-MAN**



**MANUAL MODE SELECTOR**



**NOT ENABLED**

**AUTO-MAN**



**START**



**KEY**



**RUN**

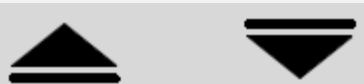

**UP - DOWNLOAD MANUAL**

**KEY**

**PROGRAMMING BUTTON**

**RUN**

**LOWERING MANUAL - ZONE 2 m.**

**ATTENTION:**



**ALL THE MOVEMENTS IN CASE OF USING THE MANUAL UP - DOWN PUSHING CONTINUOUSLY AND WITH NOMINAL SPEED.**



**WARNING:**

**IN ALL MODELS, IF THE HOIST IS IN "MANUAL" MODE, THE CONTROL FROM THE BOTTOM PANEL IS DISABLED, PREVENTING THE HANDLING OF THE HOIST BY USERS.**

### 3.3. Using "AUTO" mode.



**IMPORTANT:**  
**"AUTO" MODE IS USED FOR NORMAL HANDLING OF THE HOIST BETWEEN PROGRAMMED LEVELS, WITH BOTH CAGE CONTROL ("PERSONS") AND GROUND CONTROL ("LOADS")**

· AUTO MODE – "PERSONS" SELECTOR:

A) Transport platform PT-1200/1000F-2V:

**DESCRIPTION OF CONTROL – AUTO MODE- "PERSONS" (MAIN CONTROL BOARD)**

**AUTO MODE WITH HOIST IN THE POINT OF REFERENCE**

**AUTO MODE WITH HOIST OUT OF THE POINT OF REFER.**

LIGHT - OUT OF SERVICE

AUTO-MAN  
SELECTOR AUTOMATIC MODE

"PERSONS" MODE

DESTINATION FLOOR SELECTION

**RUN**  
SHIPPING TO DESTINATION FLOOR

**ATTENTION:**

THE MOVEMENT UP TO THE FLOOR DESTINATION OF THE HOIST IN AUTO- PEOPLE MODE WILL BE WITH THE CONTROL "RUN" PULSED IN A CONTINUOUS MANNER AND SLOW SPEED.

## B) Transport platform PT-1200/1000F-1V:

## DESCRIPTION OF CONTROL – AUTO MODE - “PERSONS” (MAIN CONTROL BOARD)

**AUTO MODE WITH HOIST IN THE POINT OF REFERENCE**

**AUTO MODE WITH HOIST OUT OF THE POINT OF REFERENCE**

**LIGHT - OUT OF SERVICE**

**AUTO-MAN**

**START**

**KEY**

**RUN**

**SELECTOR AUTOMATIC MODE**

**AUTO-MAN**

**START**

**KEY**

**RUN**

**DESTINATION FLOOR SELECTION**

**ATTENTION:**

THE MOTION TO THE FLOOR DESTINATION OF THE HOIST IN AUTO MODE – “PERSONS” MODE WILL BE AUTOMATIC AFTER PULSING “RUN”, AND AT NOMINAL SPEED.

**RUN**

SHIP TO DESTINATION FLOOR

**ATTENTION:**

IF “AUTO” MODE IS SELECTED WITH THE HOIST OUT OF REFERENCE POINT, ONLY “TOTAL DESCEND” TO REFERENCE POINT IS ALLOWED. ONCE THE HOIST UN ON REFERENCE POINT, IT CAN BE COMMISIONED AGAIN.

**ATTENTION:**

IF OPERATOR TURNS CONTROL FROM AUTO – “PERSONS” TO AUTO – “ONLY LOADS” HOIST WILL REMAIN “OCCUPIED” FOR 15sg. AFTER THAT TIME, LOWER INFERIOR CONTROL PANEL FOR USE AS “ONLY LOADS” HOIST IS ENABLED.

· AUTO MODE – “ONLY LOADS” SELECTOR (ALL MODELS):

DESCRIPTION OF CONTROLS – AUTO MODE- “ONLY LOADS” (GROUND PANEL)

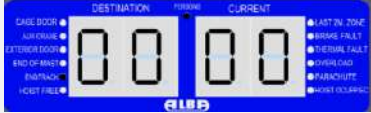

**AUTO MODE WITH HOIST  
IN THE POINT OF REFERENCE**



**AUTO MODE WITH HOIST OUT OF  
THE POINT OF REFERENCE.**

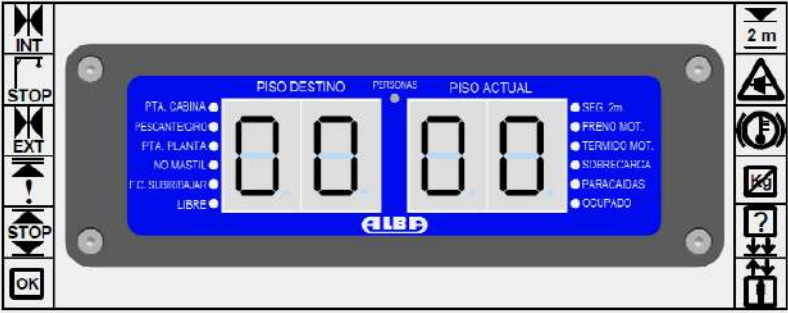





**! LIGHT - OUT OF SERVICE**



**RUN**









**MODE “SOLO CARGAS”  
(ON CAGE)**









**START**

**ATENCION:**

**THE MOTION TO THE FLOOR DESTINATION OF THE HOIST IN AUTO MODE – “ONLY LOADS” WILL BE AUTOMATIC AFTER PULSING “RUN”, AND AT NOMINAL SPEED.**

**SELECTION OF DESTINATION  
FLOOR BUTTONS**

**RUN**

**SHIP TO DESTINATION FLOOR**

**ATENCION:**

**WHEN “AUTO” MODE IS SELECTED, PERSONS USE (CAGE) OR LOADS USE (GROUND) HAVE TO BE CHOSEN. ANY EXCHANGE PERSONS - LOADS SELECTOR WHEN THE PLATFORM IS IN MOVEMENT, IS EFFECTIVE ONLY AFTER FINISHING THE CURRENT MOVEMENT.**



**ATENCION: (ONLY MODEL PT-1200/1000F-1V)**

**TO ENABLE CAGE CONTROL “KEY” BUTTON’S TO BE PRESSED. HOIST CONTROL FROM CAGE (PERSONS) IS ALLOWED FOR 15 SEC, ANNULLING GROUND PANEL. AFTER 15 SEC. WITHOUT ORDER FROM CAGE CONTROL, CONTROL RETURNS TO GROUND PANEL.**

**ATENCION:**

**WHEN “AUTO” MODE IS SELECTED, PERSONS USE (CAGE) OR LOADS USE (GROUND) HAVE TO BE CHOSEN. ANY EXCHANGE PERSONS - LOADS SELECTOR WHEN THE PLATFORM IS IN MOVEMENT, IS EFFECTIVE ONLY AFTER FINISHING THE CURRENT MOVEMENT.**

CANOPY BRANDS EUROPE, S.L.U. · +34 947 347 820 · [comercial@alba.es](mailto:comercial@alba.es) · [www.alba.es](http://www.alba.es) Rev.1.5

42

### 3.4. Security messages on the display.



#### IMPORTANT:

**DURING THE OPERATION OF THE HOIST, TWO TYPES OF SAFETY MESSAGES CAN BE RECEIVED IN THE DISPLAY:**

- MESSAGES "SECU": THE HOIST REMAINS OPERATIONAL IF IT WILL BE SAID FROM THE CAUSE OF THE SAFETY MESSAGE.
- MESSAGES "STOP": REQUIRES THE ACTION OF AN AUTHORIZED TECHNICIAN TO RESOLVE THE PROBLEM AND REACT THE CONTROL.

#### "SECU" MESSAGES (ACTION OF AN HOIST USER)

	LED	PROCEDURE
	OVERLOAD MAN	Resolve warning - Resume operation.
	AUXILIARY CRANE MAN	Resolve warning - Resume operation.
	CAGE DOORS AUTO	Resolve notice - Press RUN
	LANDING DOORS INT EXT	

#### "STOP" MESSAGES (ACTION BY AN AUTHORIZED AND COMPETENT TECHNICIAN)

	LED	PROCEDURE
	PARACHUTE MAN AUTO	1) Press UPWARDS until display shows REST 2) Press DOWNWARDS until Ref. point (FCB) → Press KEY Turn key to MAN
	NO MAST MAN AUTO	1) Press DOWNWARDS until display shows REST 2) Press DOWNWARDS until Ref. point (FCB) → Press KEY Turn key to MAN
	ENDTRACK UP MAN AUTO	1) Press DOWNWARDS until display shows REST 2) Press DOWNWARDS until Ref. point (FCB) → Press KEY Turn key to MAN
	TEMP MOTOR MAN AUTO	1) Resume relay (RT1, RT2), display shows REST 2) Press DOWNWARDS until Ref. point (FCB) → Press KEY Turn key to MAN
	FAULT BRAKE AUTO/MAN SAT	DESCEND to lower end track limit → Call Tech. service. 1) Check rectifier and rearm E4 → display shows RESET 2) Press KEY.

#### NORMAL MESSAGES

ENDTRACK DOWN 2 m. ZONE	Ref. point platform (FCB) 2 m. safety zone platform
HOIST FREE	Platform stopped and prepared
HOIST BUSY	Platform moving or busy
PERSONS	Control inside cage activated

(FCB): Inferior End track. Reference point for hoist movements.



#### IMPORTANT:

**IN CASE OF SHOWING "STOP" MESSAGE, YOU MUST GO TO "MANUAL" MODE, AND FOLLOW THE INDICATIONS OF THE TABLE, UNTIL THE DISPLAY MARK "RSET" (RESET), TURN OFF THE ELEVATOR TO THE REFERENCE POINT (FCB) AND PRESS THE RESET BUTTON (KEY).**



#### IMPORTANT:

**MAKE SURE THAT THE CAGE DOORS ARE PROPERLY CLOSED AND LOCKED BEFORE MOVING THE HOIST.**

**OTHER MESSAGES IN THE DISPLAY**

MANUAL Mode selected



Total descent to FCB (Ref. point) and RESET



Total descent to FCB (Negative Ref. point)



Memory error (ERASE MEMORY)



Reset control (PRESS KEY in FCB)



Hoist in AUTO mode and in FCB

**3.5. Emergency lowering.**

In case of power failure without the possibility of restoration, you can descent the cage handpicked, acting **WITH EXTREME CAUTION** on the release levers of the motor brakes on the cage roof. This must be done in small intervals to avoid machine acceleration.



**CAUTION: DANGEROUS TASK**

**IF SAFETY GEAR SPEED IS EXCEEDED, PARACHUTE IS AUTOMATICALLY ENGAGED, BLOCKING ANY FURTHER CAGE MOVEMENT UNTIL TECHNICAL ASSISTANCE.**

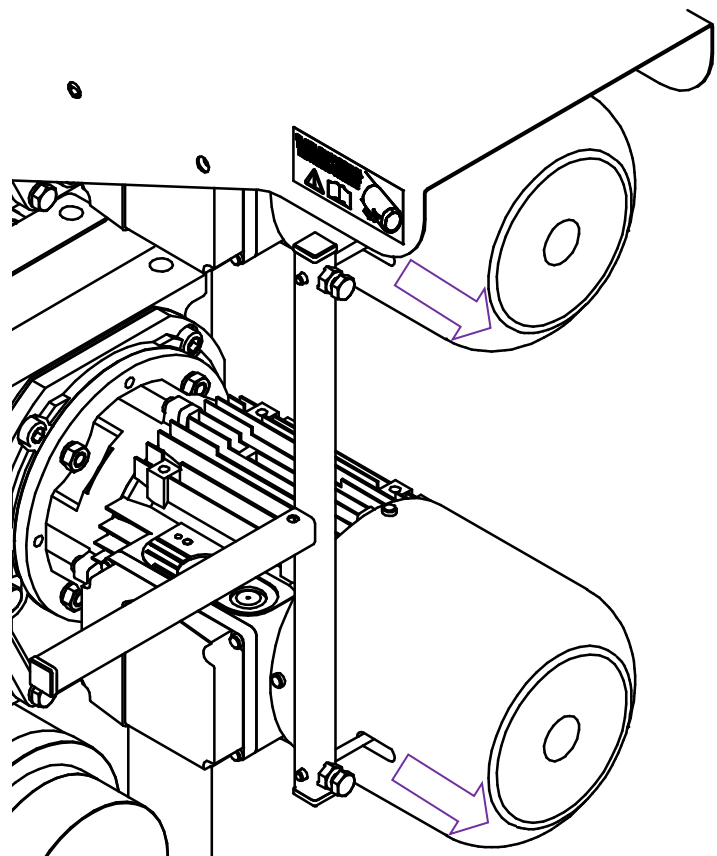
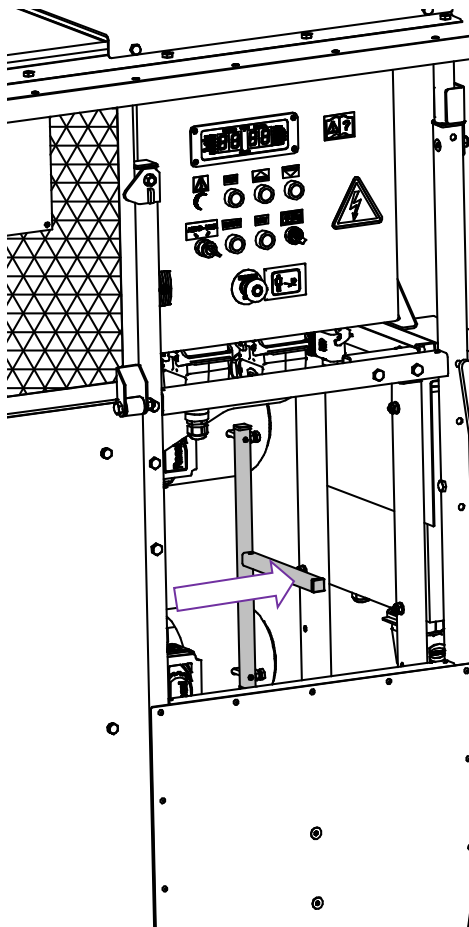
**EMERGENCY LOWERING PROCEDURE**

**WARNING:**

**CASE OF PARACHUTE ACTIVATION HOIST SERVICE WILL BE SUSPENDED AND TECHNICAL SERVICE WILL BE NOTIFIED FOR INSPECTION AND HOIST RELEASING.**

### 3.6. Checking hoist operation before commissioning.

**IMPORTANT:**

**BEFORE HOIST COMMISSIONING, HOIST SERVICE RESPONSIBLE WILL CHECK IF HOIST IS IN COMPLIANCE WITH FOLLOWING POINTS:**

- Hoist´s installed with all operational safety systems:
  - Landing levels are properly programmed.
  - No destination can be chosen over last floor programmed.
  - FCS microswitch stops hoist before reaching red mast.
  - Overload detector (inductive sensor) works properly.
  - The brakes support the maximum load correctly.
  - FCB microswitch stops hoist on Ref. Point before reaching buffers.
  - The mast presence detector works correctly.
  - Display shows safety activations and operational LEDs correctly.
  - Landing levels hoist calling system works OK (if installed).
  - Hoist control inside cage works properly.
- There´s no interference of hoist and external items, mast, ties, supporting structure, ...
- Landing doors are installed and there´s no interference with hoist mobile elements.
- Base fence is installed and there´s no interference with hoist mobile elements.
- Door releasing system for cage door / landing door / fence door are operative.
- Control microswitch for cage door / landing door / fence door work correctly.
- The points of access to the platform and hoist way have adequate lighting.

**IMPORTANT:**

**KEEP ORDER AND CLEANING IN THE ELEVATOR AND SURROUNDINGS**

### 3.7. Use of the hatch.

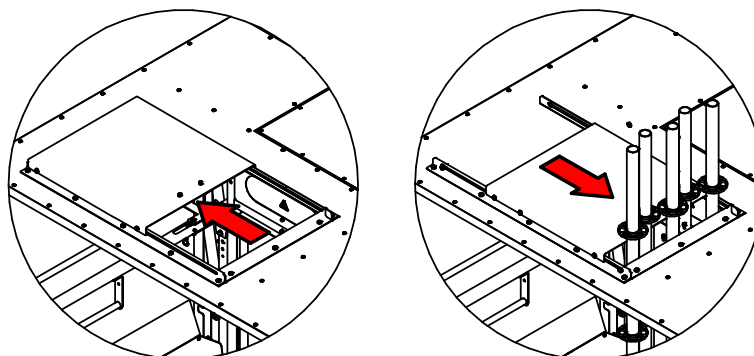
**ATTENTION:**

**THE USE OF THE HATCH IS LIMITED TO THE TRANSPORT OF MATERIAL WHOSE LENGTH EXCEEDS THE DIMENSIONS OF THE BASKET. THE HATCH OPENING SHALL BE ADJUSTED TO THE DIMENSIONS OF THE LOAD, AVOIDING UNNECESSARY GAPS IN THE ROOF OF THE BASKET.**

### 3.8. Notes on the use of -1C platforms (equipped with BATT)

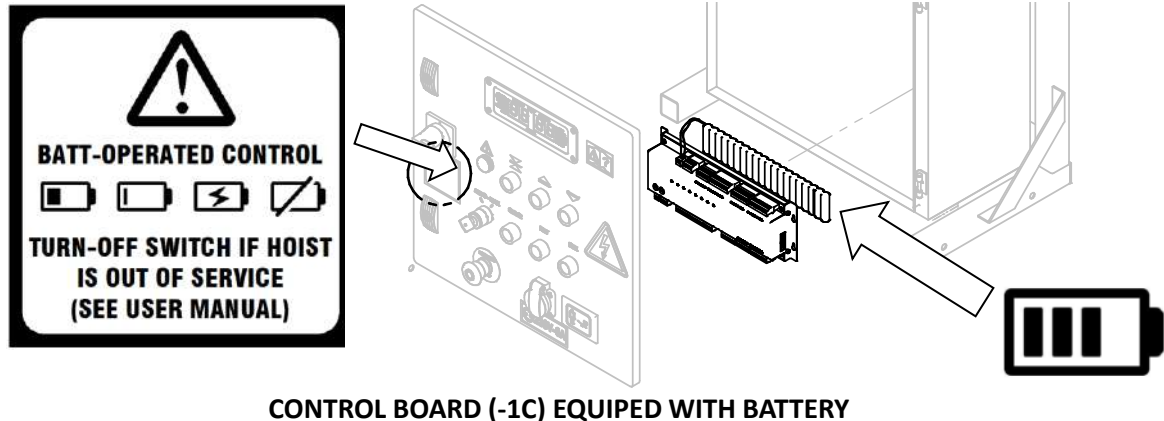

#### ATTENTION:

PLATFORM MODEL -1C EQUIPED WITH ONLY POWER CABLE HAS A BATTERY TO AVOID LOSS OF POWER SUPPLY TO THE CPU WHEN THE PLATFORM IS STOPPED ON A LANDING LEVEL IN SERVICE.

CLOSE THE DOORS AND RESTART THE CONTROL, TO AVOID DISCHARGING THE BATTERY, OR SWITCH OFF THE CONTROL IF IT IS TO REMAIN STATIONARY FOR A LONG TIME.

### 3.9. Applications and uses forbidden.

- DON'T use the hoist on explosive atmospheres.
- DON'T use the hoist with higher load than shown in the plate.
- Load CAN'T be piled up at the cage floor bounds, **it must be located as near mast as possible**.
- DON'T transport loads out of cage floor.
- DON'T use the hoist in adverse weather conditions, rain, ice, snow, (See Ap. 1.3) ...
- DON'T use the hoist in unacceptable physical condition, treatment of serious illness, under alcoholic drinks effects, or under stress or mental overload condition.
- DON'T use the machine with other parts than those originals from the manufacturer.
- DON'T work without the necessary personal protection gear. These safety devices will vary upon different conditions, therefore, a qualified person in the requirement of safety and health must evaluate the working conditions and mode of use before starting works.
- DON'T access the elevator with inappropriate clothing, hanging chains, rings or loose long hairs.
- DON'T put raised brackets on the cage floor. If travelling, user's feet must be on the cage floor.
- DON'T use the hoist if the key switch has been forgotten in the lock and can be manipulated.
- DON'T dismantle integrated equipment whose maintenance is only allowed authorized personnel (i.e.: electrical motor, brake, gear-reductor).
- DON'T manipulate electrical system without express permission of the manufacturer.
- DON'T use the hoist without a differential switch on the main power supply connection line.
- DON'T use the machine with personnel traveling in the basket in MANUAL mode, except in the case of maintenance tasks and by authorized personnel.
- Do not use the machine under insufficient lighting conditions. If necessary, local lighting will be installed at access points, illuminating the hoist way. You will also install local lighting in the control panel area, which allows the correct vision of the elevator controls as needed, using the auxiliary power outlet available in the upper part of the panel.

## 4. SAFETY DEVICE. PARACHUTE FPC-1000

### 4.1. Introduction

According to the specifications of Directive 2006/42/EC, the hoist must have a safety device for mechanical locking to act if the speed exceeds a set value. The parachute safety system is a mechanical unit designed to prevent accidental loss of the machine. The system only operates during the fall, when the speed exceeds a predetermined value, acting as a hoist speed tracker, not making any effort on lifting device, during normal operation of the machine.

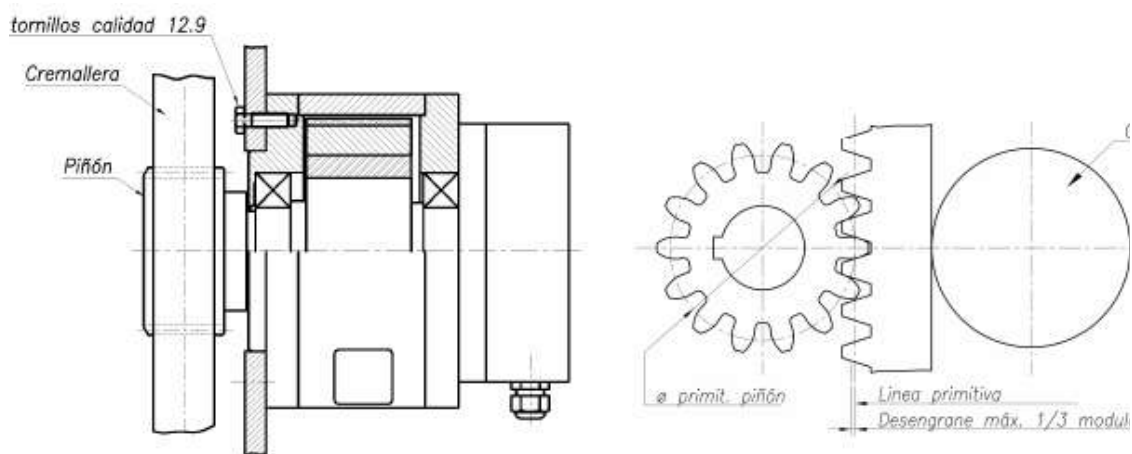

ASSEMBLY OF PARACHUTE. GENERAL DESIGN

**4.2. Features:**

A parachute works by blocking the drop in the case of there is a speed rising over the nominal value. The overspeed detection system is based on the principle of action of the centrifugal force to engage driven pinion into the elevator structure. On the elevators there are two intermediate crowns as parachute pinion and rack transmission. Its main components are as follows:

**• Cover:**

The parachute has waterproof housing that allows confining the security unit, preventing it from dust and corrosive atmosphere inside. It must also prevent unauthorized adjustment, so that screws should not be handled by unauthorized persons.

**• Buffer:**

The parachute has a progressive braking system so that locking is produced in a buffered way, so that after a controlled braking, the cage is stopped, according to deceleration specifications of reference standards to avoid accidents resulting from major efforts generated by moving mass inertia.

**• Locking:**

The device features a brake consisting of four sectors, which are charged up to torque referred to the elevator, so that deceleration is controlled accurately, even in case of free drop of the machine, according to the specifications of harmonized standards reference.

**• Integrated microswitch:**

The parachute includes a microswitch that is activated in case of brake locking, allowing the signal to cut the movement of hoist and preventing further operations of the machine, until the action of a person designated to release the hoist.

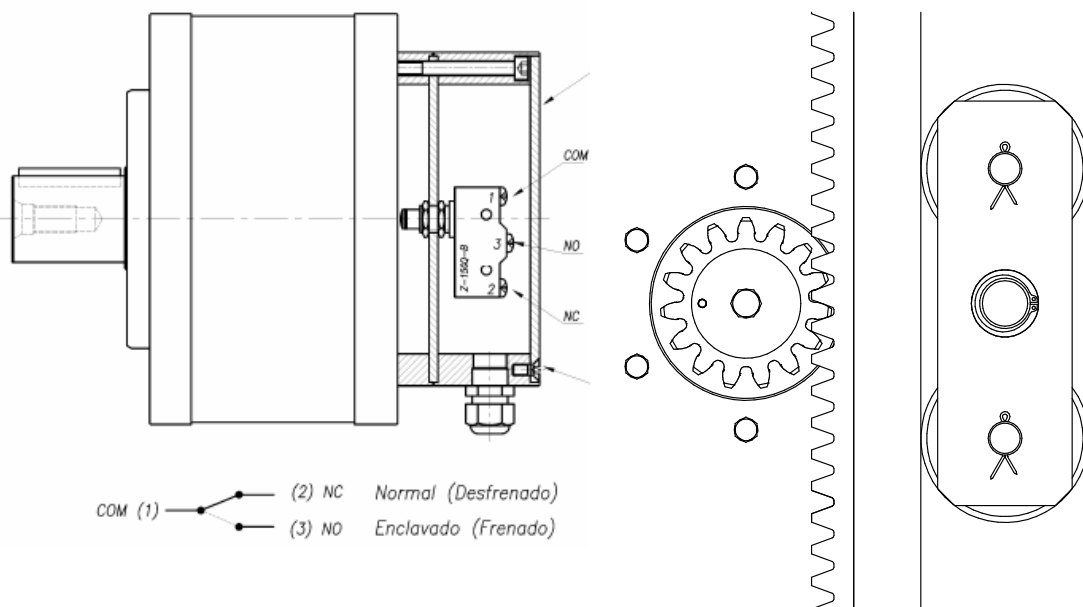

**SAFETY SWITCH AND INTERNAL CONNECTION**

**SAFETY PINION AND COUNTER-ROLLER**

• ID plate and features of the device:

The parachute is equipped with an identification plate, with CE logo stamped and brake characteristics:

- Brake type, mounting position and lock sense.
- Locking speed (r.p.m.) and brake torque (N·m)
- Number, date and reference of manufacture.



ID PLATE EXAMPLE ON THE PARACHUTE

### 4.3. Installing the parachute

The unit shall be firmly fixed to the chassis of the cage, so that the pinion is centred with the hole, to rotate at the speed of normal movement of the elevator. The unit must be fitted to the hoist with all screws and safety washers.

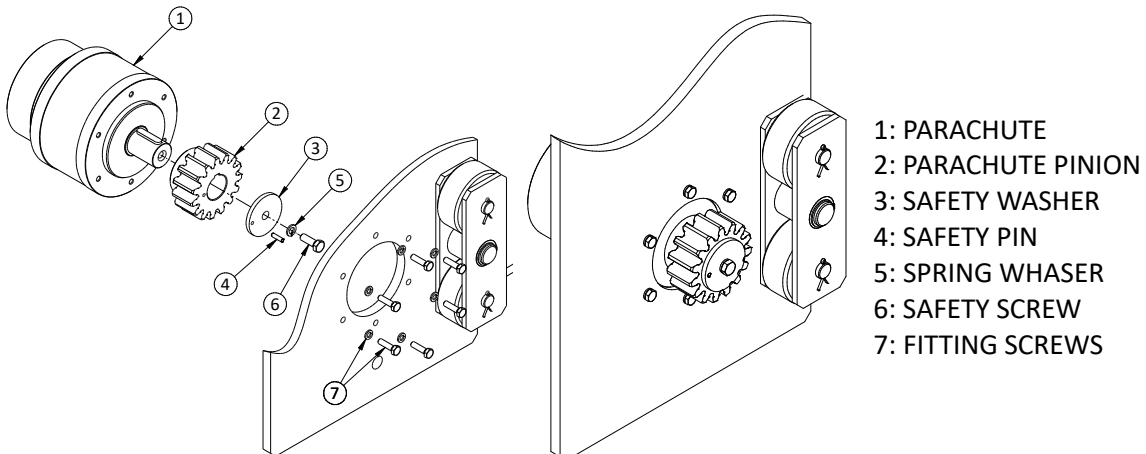

- 1: PARACHUTE
- 2: PARACHUTE PINION
- 3: SAFETY WASHER
- 4: SAFETY PIN
- 5: SPRING WHASER
- 6: SAFETY SCREW
- 7: FITTING SCREWS

INSTALLING SAFETY UNIT IN TO THE HOIST



**WARNING:**

**DON'T INSTALL A PARACUTE IN A HOIST WITH OTHER FEATURES THAN THOSE MARKED IN THE PLATE**



**WARNING:**

**HANDLING AND TESTING OF THE PARACHUTE ONLY IS ONLY ALLOWED TO THE MANUFACTURER OR AUTHORIZED SERVICE PERSSONEL.**

Finally, install the safety switch wire on its correct position, according to the scheme, to avoid further movement of the hoist if the safety device locks, until the actuation of technical personnel.

Once the assembly of the unit is finished, install back cover, so the device remains watertight and mechanical characteristics of the parachute are preserved along the time. Nobody but the manufacturer is allowed to manipulate screws of the unit itself.

#### 4.4. Parachute testing.

In accordance with the reference harmonized standard, tests on the parachute must be performed, to verify its functioning properly.

##### A) MANUFACTURER TEST

ALBA performs a test on each lift during the machine assembly to ensure the safety and proper functioning of the device. The test result is reflected in the TEST CERTIFICATE, which accompanies this manual of the machine.

##### B) USER TEST

Periodically, **every 4 months**, or **after each assembly machine on site**, a functional test of the parachute shall be performed, in accordance with the instructions set out below. The test of the parachute must be further supplemented with a brake inspection, checking the correct appearance of all the elements and the sealing of the outer cover. This process is repeated more often if the machine operates in extreme environmental conditions.

#### PARACHUTE TEST PROCEDURE



##### WARNING: (PT-1V)

**FOR SAFETY PURPOSE, RELAY HEAD "RDP" IS NOT MOUNTED. INSTALL IT BEFORE TEST, THAT WAY TEST BOARD WORKS. AFTER TEST, REMOVE "RDP"**

- 1.- The area under the machine must be free of people and obstacles.
- 2.- The hoist shall be securely fastened to the facade or structure.
- 3.- Remove the parachute bridge on the mainboard and connect the pendant control.
- 4.- Leave the hoist and put into the cage **MAXIMUM** load and take position at safe distance.
- 5.- Raise the hoist with pendant control and stop it at approx. 3 m above the ground.
- 6.- Turn on the left "TEST" key and let the hoist drop until parachute activates and cage stop. Check if elevator stops after a little slip, and then it's blocked for further descent movements.

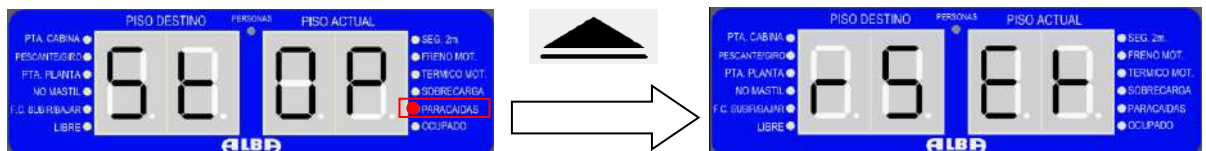

- 7.- To release the parachute, it's necessary to press "UP" for a while, until display shows RESET. Then hoist can be recovered and must be descended to reference point. After pressing "KEY" button to reset, the hoist is released and can be commissioning again.



##### IMPORTANT:

**TEST THE PARACHUTE PERIODICALLY AND WRITE THE RESULT IN THE OPERATOR'S MANUAL REGISTRATION.**

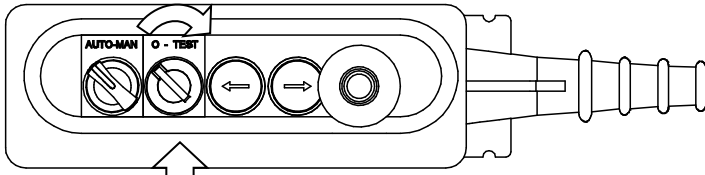

**ATTENTION:  
HAZARDOUS OPERATION!**

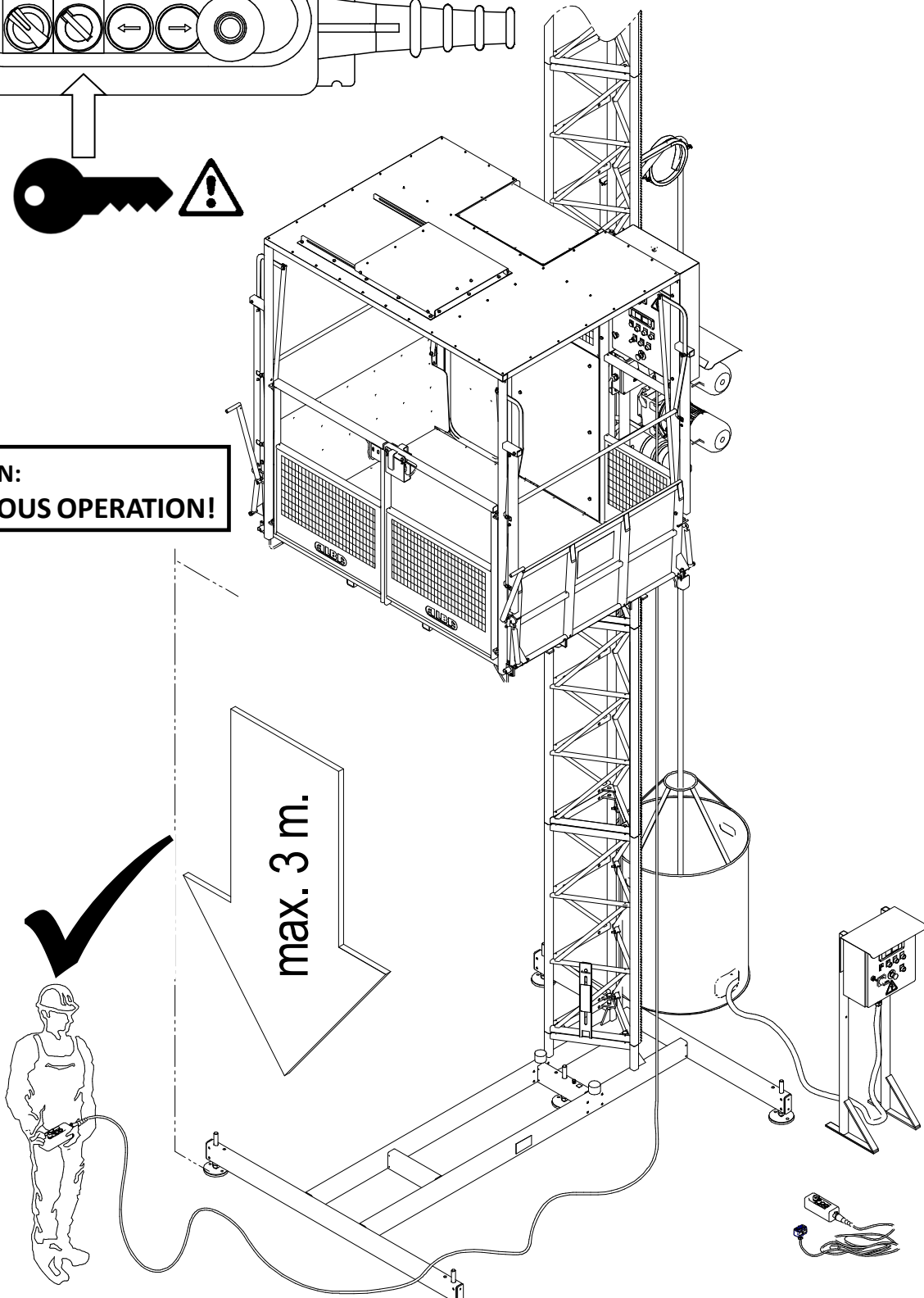

**PARACHUTE TEST PROCEDURE**

#### 4.5 Actions to take if safety device is activated.

The parachute is activated in case that the emergency lowering speed exceeds normal download speed of the hoist. This can only happen in the following cases:

- A) Case of power failure or electrical malfunction, and it is necessary to descent the hoist manually, using the manual lever to release the brake of motor, and this procedure is performed without considering the information in this manual operator, exceeding the speed of the parachute limit.
- B) Case of accident or structural failure that causes gear pinion disengage or gearmotor shaft breaking or any of its elements.
- C) Case of parachute testing.

Case of scenario A or C, the person who performs emergency descent will be a qualified technician who is trained to release device and reset the hoist. This requires connecting the keypad to test and reset parachute.



**ATTENTION:**  
**MOTOR BRAKE MANUAL RELEASE ONLY IS ALLOWED TO TECHNICAL PERSONNEL AUTHORIZED TO TRAVEL ON THE ROOF OF THE CAGE.**

In case of occurrence of case (B) shall cease machine operation until the action of an authorized technician which chooses the best option depending on the severity of problem. If there is no clear solution, perform the disassembly of the machinery with auxiliary means.

#### 4.6. Replacement of parachute

Following the instructions of the safety device manufacturer, to ensure integrity of the device, along the time, parachute shall be replaced after **6 YEARS** from the date of installation on the hoist. See installation plate.

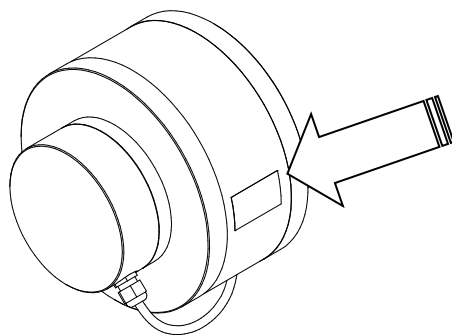

Fecha de instalación:	Installation date:	01 -2025
Date de installation:		
Fecha de sustitución:	Replacement date:	01 -2031
Date de replacement:		

#### INSTALLATION AND REPLACEMENT PLATE

· For more information: <https://www.eide.net/en/productos/fpc-overspeed-safety-brake/>



**IMPORTANT:**  
**AFTER REPLACEMENT OF THE PARACHUTE, DROP TEST OF THE NEW DEVICE MUST BE PERFORMED. WRITE THE RESULT IN THE USER'S MANUAL LOG.**

## 5. MAINTENANCE OF THE MACHINE.

**WARNING:**

**BEFORE PERFORMING ANY MAINTENANCE ACTION, TURN THE POWER OFF AND IF REQUIRED, BLOCK VERTICAL MOVEMENT AT LEAST 1.8 m. HEIGHT UNDER THE CAGE. MAINTENANCE TASKS MUST BE PERFORMED WITHOUT LOADS.**

### 5.3. DAILY Maintenance.

Daily maintenance includes basic operations of visual inspection in the hoist, performed by the person responsible of the hoist on the building. Every day, prior to use, visual inspection of the elevator should be done, according to the following service points:

- There's no accumulation of ice, snow or debris inside the cage, or near the hoist.
- There's no excessive wear in the rack, or in the vertical pipe of the mast.
- All the cage protections are installed, and there's no dangerous holes or gaps.
- Identification and characteristics plate is installed inside the cage.
- Zone below hoist is bounded and base fence is installed.
- There isn't any warped or cracked part (Case of, change it).
- Electrical wires are correctly installed and tightly guided on the hoist.
- Guide rollers are in touch with mast tube and without excessive wear.
- There are no power lines near the hoist that endanger people or machine.
- There are no outgoing elements in the facade that may interfere with the machine.
- Electrical safety devices are operational (doors, end track switch, mast sensor).
- Emergency stop works properly.
- Facade anchorages are correctly installed.
- Cage door, fence door and landing door auto-lock system work properly.
- Cage floor and walls are in good condition.
- Rack-pinion transmission is correctly engaged.
- Control and power boards are in good condition
- Cage lamp lights properly.
- All the controls, panels and indicators work properly.
- Cable travels and slides over the cable holder properly.

After reviewing all the checkpoints listed, and solved any problem, the machine can be used safely.

## 5.2. Periodic maintenance schedule







**WARNING:**

**IN CASE OF ELECTRICAL MALFUNCTION IN THE HOIST, DO NOT HANDLE ELECTRICAL EQUIPMENT. MAINTENANCE AND INSPECTION OF THE HOIST ONLY MUST BE PERFORMED BY AUTHORIZED PERSONNEL.**

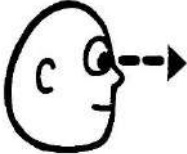

Maintenance of the lift must be performed by the staff responsible for the machine and the results must be recorded on the MAINTENANCE RECORD.

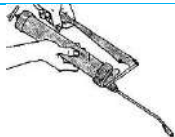
### MAINTENANCE TASKS SCHEDULE

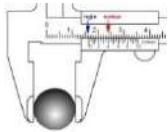
OPERATION	ELEMENT	TOOL	PERIODICITY
1 	<ul style="list-style-type: none"> <li>• FIXING BOLTS CAGE-CHASSIS (CHECKING).</li> <li>• ENDTRACK CAMS.</li> <li>• MAST SENSOR (CHECK GAP: ±5 mm.).</li> <li>• MOTORGEAR OIL LEVEL.</li> <li>• DOOR MICROSWITCH</li> <li>• LOAD CELL (CHECK FUNTION)</li> <li>• SWITCHBOARD LIGHTS ANS BUTTONS.</li> <li>• MAST TUBES (WEAR OR WELDING FAILURE).</li> <li>• GUIDE ROLLERS RETAINING RINGS.</li> <li>• MOTOR BRAKE RECTIFIER (CHECK FUNCTION)</li> <li>• COMMUNICATION CABLE (INSPECTION)</li> <li>• GUIDE ROLLERS (INSPECTION).</li> <li>• ANCHORAGE (CHECK INTERFERENCE OR LOOSENING)</li> <li>• BASE BUFFERS (INSPECTION)</li> <li>• GRASE LEVEL OF AUTOMATIC GREASER (OPC.)</li> </ul>	-	40 h WORK (ONCE A MONTH)
2 	<ul style="list-style-type: none"> <li>• MAST RACK</li> <li>• GEARMOTOR PINION.</li> <li>• PARACHUTE PINION.</li> </ul>	LITHIC GREASE	40 h WORK (ONCE A MONTH)
3 	<ul style="list-style-type: none"> <li>• CAGE GUIDE ROLLER ROCKER</li> </ul>	LITHIC GREASE	40 h WORK (ONCE A MONTH)
4 	<ul style="list-style-type: none"> <li>• MAST SCREWS.</li> <li>• GUIDE ROLLERS SCREWS.</li> <li>• BASEFRAME TO GROUND SCREWS.</li> <li>• ANCHORAGE TO SUPPORTING STRUCTURE SCREWS</li> <li>• DOOR FOLDING SYSTEM SCREWS</li> </ul>	SPANNER	QUARTERLY (4 TIMES/YEAR)
5 	<ul style="list-style-type: none"> <li>• ROLLER GUIDE DIMENSION CHECKING</li> <li>• MAST RACK DIMENSION CHECKING</li> <li>• GEARMOTOR PINION CHECKINGS</li> <li>• BRAKE MOTOR CHECKING</li> </ul>	CALIBER CALIBER MICROMETER GAUGES	ANNUAL (OR AFTER DISMANTLING)
6 <b>GENERAL REV.</b> <small>(AFTER DISMANTLING OR PROLONGED NON-USE PERIOD)</small>	<ol style="list-style-type: none"> <li>1. DEFORMATION OR DAMAGE ON MASTS, ANCHOR, DOORS, HANDRAILS, FLOOR...</li> <li>2. GEARMOTOR AND BRAKE INSPECTION (Rectifier, Voltage &amp; Coil resistance)</li> </ol>		

**MECHANICAL CHECKING DIAGRAM**

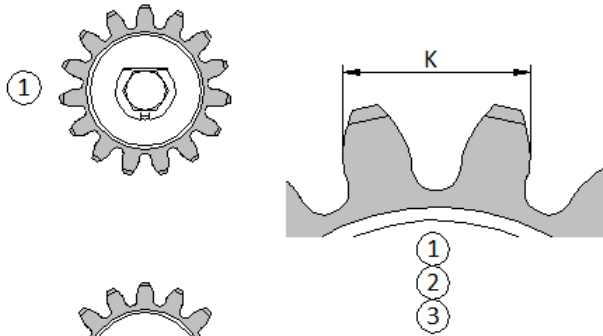

CONTROL DISTANCE K [mm]		
	Nom.	Min.
PINION 1 - Z15	27,82	25
PINION 2 - Z15	27,82	25
PINION 3 - Z15	27,82	25

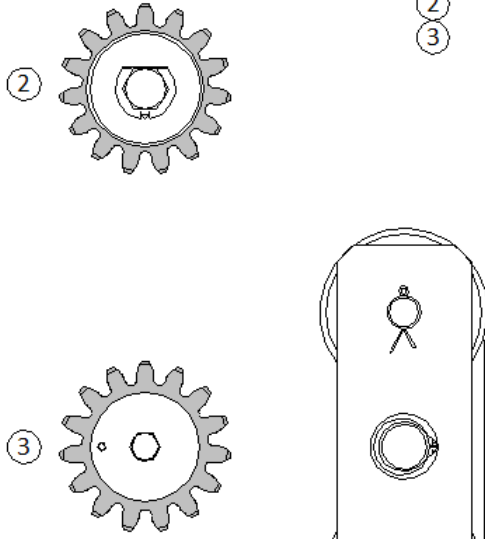

OVERLAP [mm]		
	Nom.	Min.
□	11	8
DC	10	5

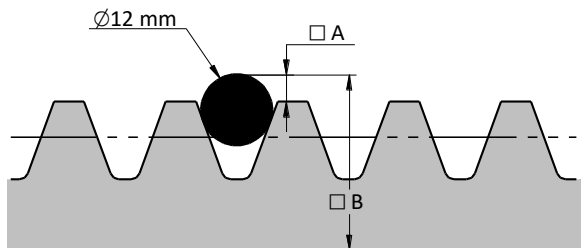
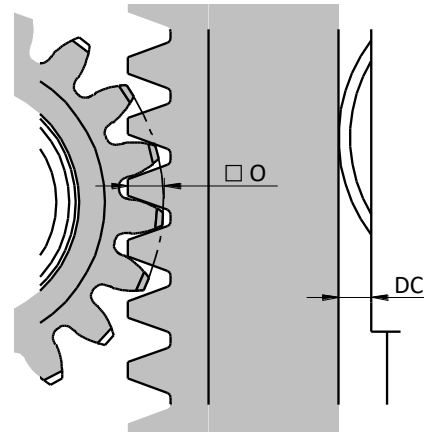

CONTROL DISTANCE □ [mm]		
	Nom.	Min.
□ A	4,6	3,4
□ B	29,6	28,4

**CHECKINGS FOR RACK AND PINION**

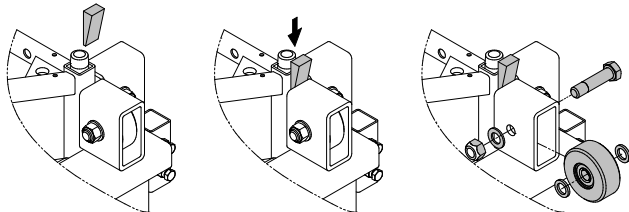
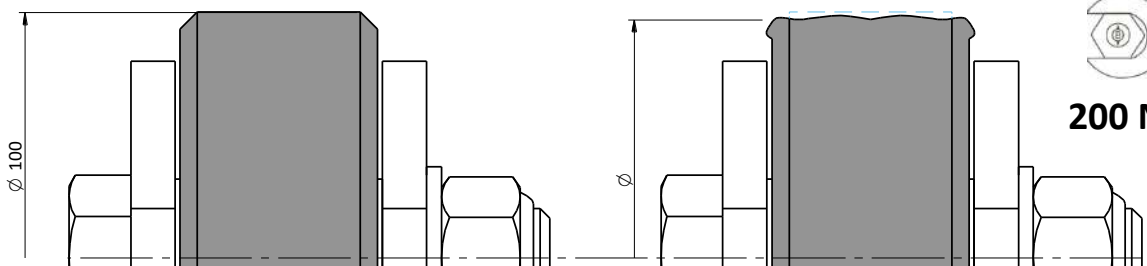

CONTROL MEASURES [mm]		
	Nom.	Min.
∅	∅100	∅97

**DISMANTLING ROLLER GUIDE PROCEDURE**



**ATENTION:**

**ENSURE ROLLER'S WEAR IS UNIFORM ALONG THE CONTACT'S CIRCUNFERENCE**

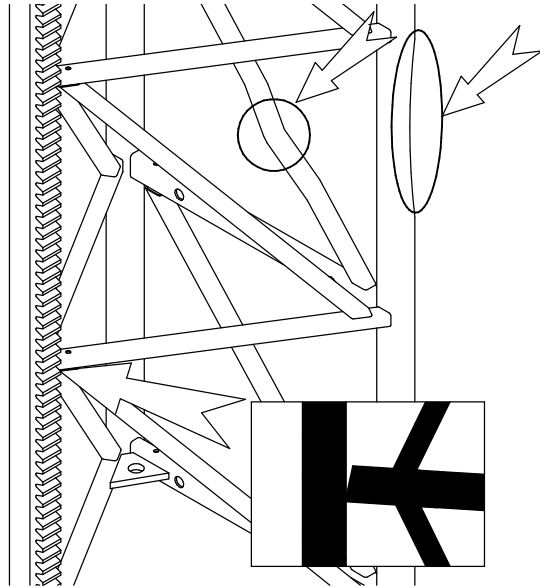
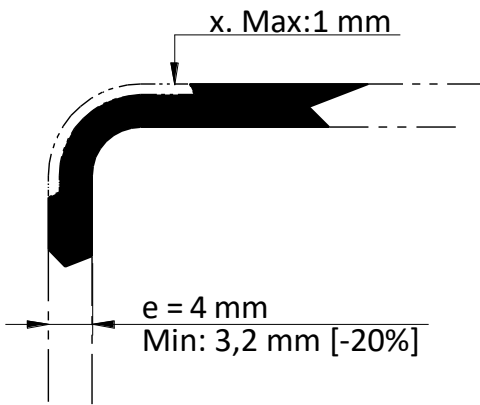

**CHECKINGS FOR MAST WEAR**



**ATTENTION:**  
**CHECK FOR POSSIBLE DAMAGES AND EXCESSIVE WEAR ON MASTS BEFORE AND AFTER ERECTION TAKEN INTO ACCOUNT PERIODICITY INDICATED**

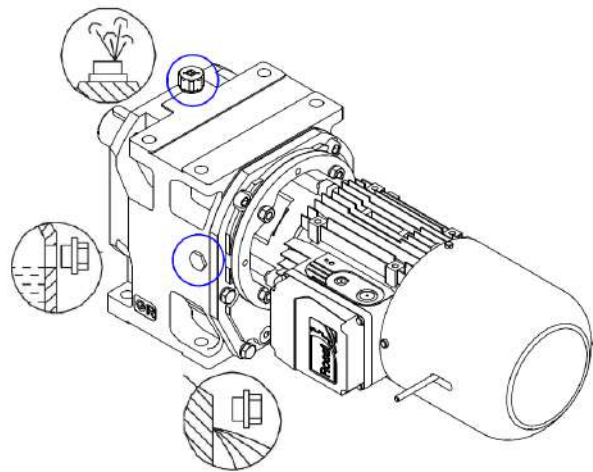
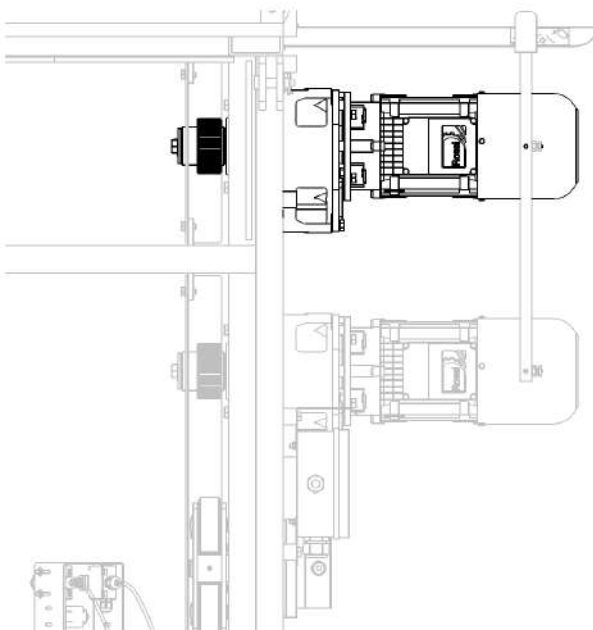

OIL PLUGS POSITION

Properties			Method	Shell Omala S4 GXV 220
Kinematic Viscosity	@40°C	mm <sup>2</sup> /s	ASTM D445	220
Kinematic Viscosity	@100°C	mm <sup>2</sup> /s	ASTM D445	30
Viscosity Index			ASTM D2270	171
Flash Point (COC)		°C minimum	ASTM D92	240
Pour Point		°C	ASTM D97	-42
Density	@15°C	kg/m <sup>3</sup>	ASTM D4052	864
Four Ball EP Weld load		kg minimum	ASTM D2783	250
FZG Load Carrying Test		failure load stage minimum	A/8,3/90	14

**MOTOR GEAR MAINTENANCE**



**IMPORTANT:**  
**MOTOR GEARS ARE INSTALLED FILLED OF 220 SYTHETIC OIL FOR ITS LIFE-TIME LUBRICATION, IN ABSENCE OF EXTERIOR CONTAMINATION. REPLACE THE OIL IF NECESSARY. REPLACE WITH OIL ACCORDING TO THE GRADE INDICATED.**



**IMPORTANT:**  
**MOTORGear OIL IS GOOD TO USE IN RANGE 0°C < T<sub>a</sub> < 40°C (32°F < T<sub>a</sub> < 104 °F) WITH PEAKS -20°C < T<sub>a</sub> < 50 °C (-4°F < T<sub>a</sub> < 122°F). REPLACE OIL COMPLETELY. DO NOT MIX DIFFERENT OILS.**

**AUTOMATIC GREASING SYSTEM (OPT)**

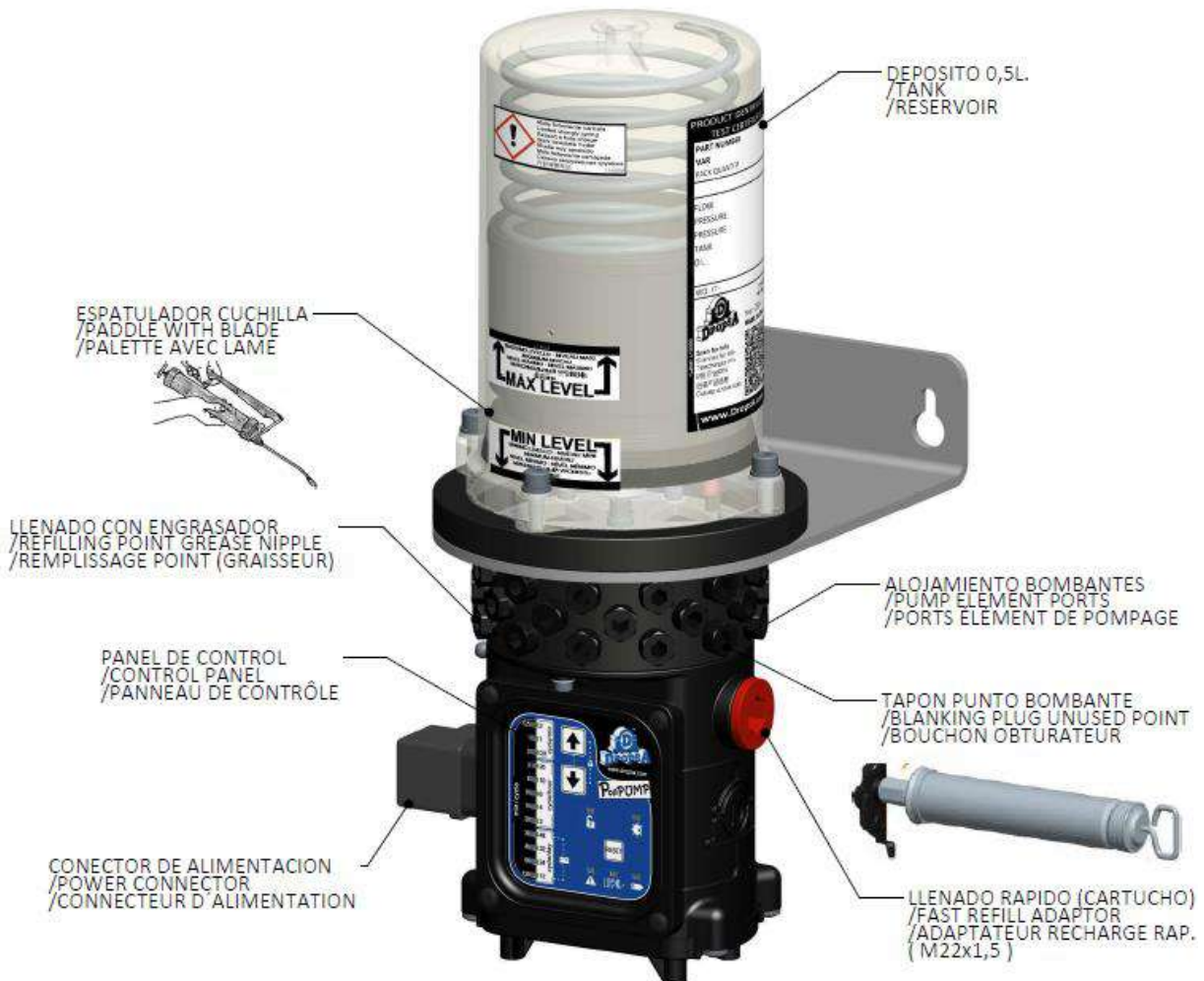

**AUTOMATIC GREASING CENTER**

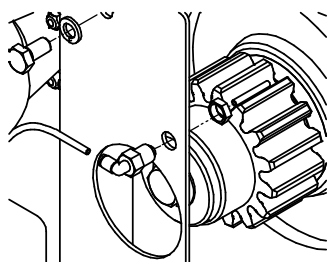

**PINION GREASING POINTS POSITION**

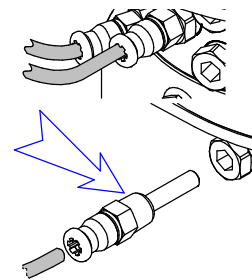
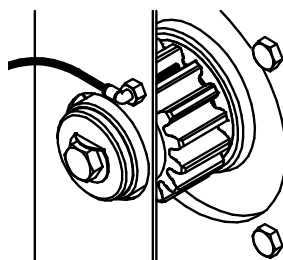

**GREASING FLOW DISTRIBUTOR**

### GREASING SYSTEM TECHNICAL FEATURES

Grease TYPE	Lithium grease	
Types of grease allowed:	NLGI	ASTM
Very soft	0	355 – 385
Medium soft	1	310 – 340
Medium (Recommended)	2	265 - 295
Tank capacity:	0,5 l.	
Lubrication speed:	2x12 gr/h.	
Tank life:	~ 70 h. (Hoist working)	



- CONTROL LOCKED (PRESS ↑↓ TO UNLOCK)**
- YELLOW – GREASING PUMP WORKING**
- RED – GREASING MOTOR BLOCKED**
- RED – MIN. GREASE TANK LEVEL**
- RED – VOLTAGE UNDER MIN. LEVEL**
- CANCEL ALARM / GREASING EXTRA CYCLE**
- INCREASE OR REDUCE GREASING FREQ. /CYCLE.**
- SIMULTANEUNS PRESS. – LOCK CONTROL**

**GREASING UNIT CONTROL CONSOLE**

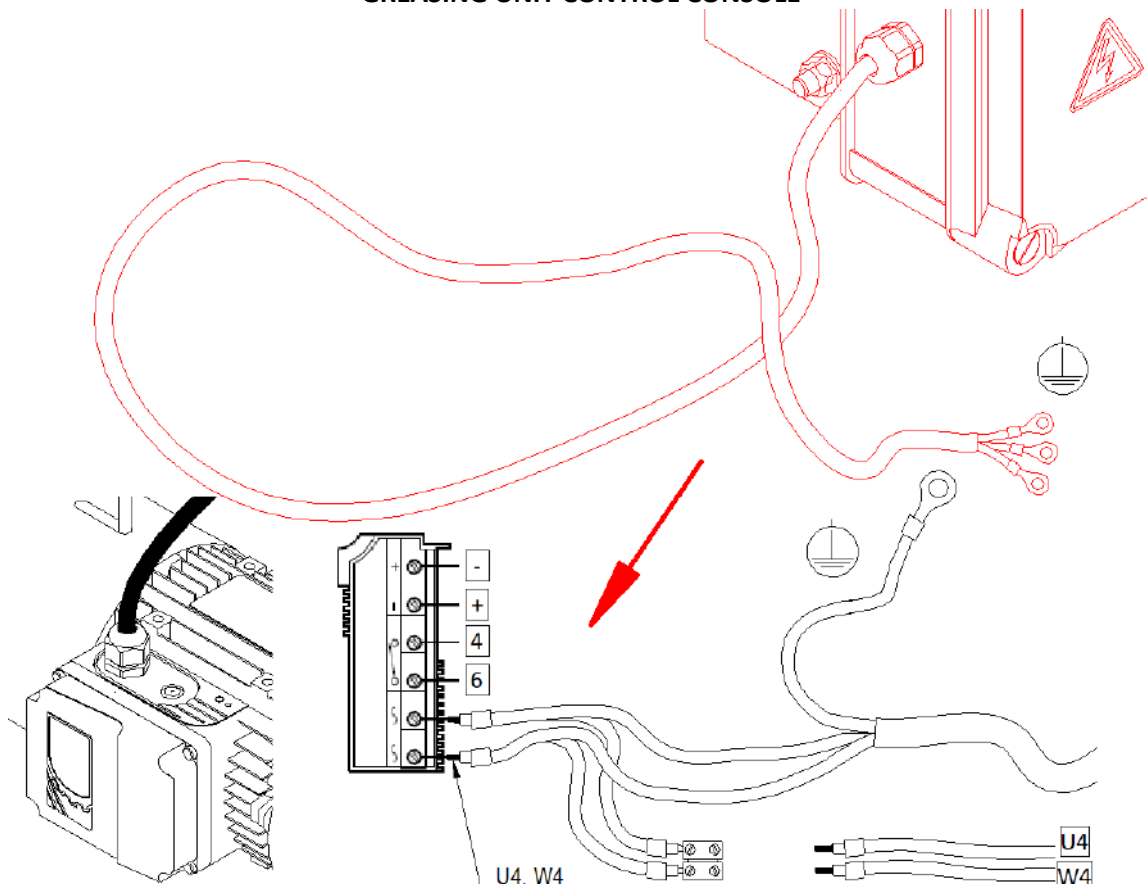

**ELECTRIC CONNECTION OF GREASIG SYSTEM (PT-1200/1000F-2V)**

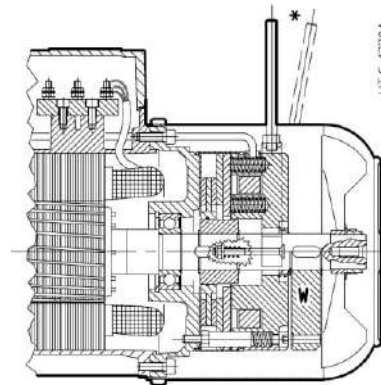
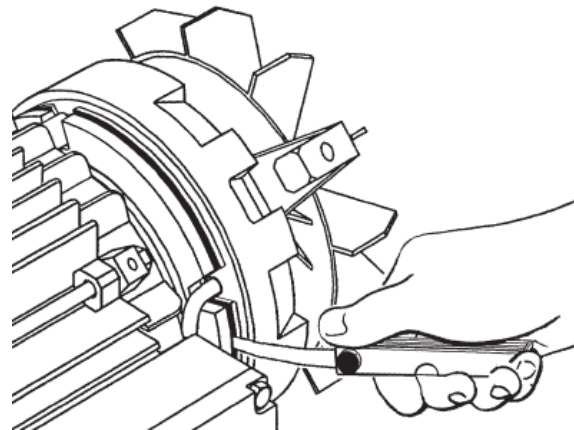
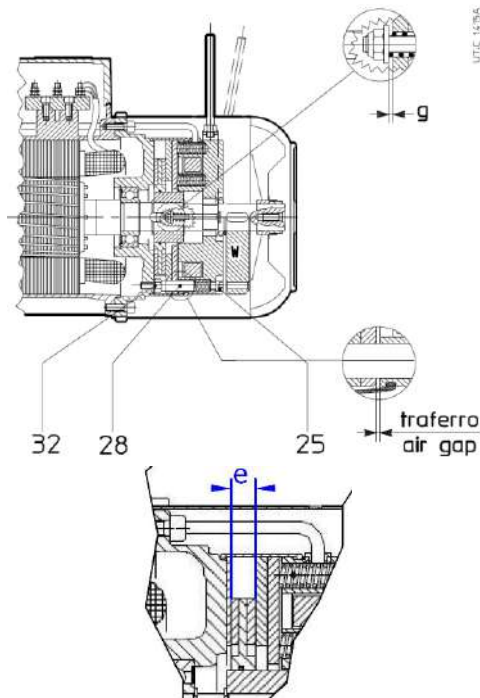
**INSTRUCTION FOR MAINTENANCE OF ELECTRIC MOTOR-BRAKE**

**MOTOR BRAKE WITH D.C. BRAKE AND MANUAL RELEASE LEVER**

**CONTROL MEASURES [mm]**

	Nom.	Max.	Min.
Air gap	-	0,45	0,30
Brake disc thickness (e)	-	-	7
Lever play (g)	0,6	-	-

**BRAKE DISC ADJUSTMENT**



**IMPORTANT:**  
**AIR GAP HIGHER THAN THE MAXIMUM VALUE MAY AFFECT BRAKE TORQUE. CHECK PERIODICALLY AIR GAP AND BRAKE DISC THICKNESS.**

**BRAKE ADJUSTMENT PROCEDURE:**

1. Unlock nuts **No.32**, located on 3 positions spaced 120°
2. Tight fixation bolts **No.25** [in case of flywheel, act through the available holes] up to reach the minimum airgap measured in 3 positions spaced 120° with feeler gauges, as close as possible to guides **No.28**.
3. Tight nuts **No.32** keeping same position of fixation bolts **No.25**.
4. Check final airgap and compare with values indicated on table.

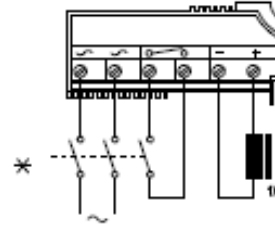
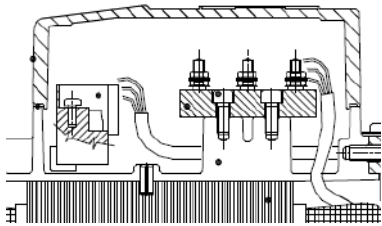

**IMPORTANT:**  
**AFTER SEVERAL AIR GAP ADJUSTMENTS, VERIFY THE BRAKE THICKNESS (e) IS NOT LOWER THAN MINIMUM INDICATED ON TABLE. REPLACE IF NECESSARY**



### BRAKE'S D.C. SUPPLY RECTIFIER

RECTIFIER CHECK TABLE

a) Vac power supply	( ~ . ~ )	230 Vac
b) Vdc power output	( - . + )	75 – 105 Vdc
c) Coil resistance (*)	( - . + )	±250 Ω

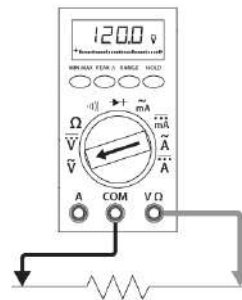
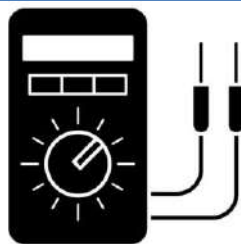

a) ~.~ ; b) - . +

c) Ω

### RECTIFIER CHECKING



**IMPORTANT:**  
CHECK POWER INPUT/OUTPUT WITH HOISTS UNDER MOVEMENTS TO ENSURE RECTIFIER FUNCTIONS. ATTENTION! ELECTRIC RISK



**IMPORTANT (\*):**  
TO CHECK BRAKE COIL CONDITION, REMOVE SUPPLY CABLES FROM RECTIFIER (+, -) AND CHECK RESISTANCE READING ACCORDING TO PROCEDURE c). REPLACE IF NECESSARY.



**IMPORTANT:**  
AFTER BRAKE ADJUSTMENT, CHECK RELEASE IF LEVER BAKCLASH (g) ALLOWS MANUAL BRAKE RELEASING PROPERLY. IF NECESSARY, AMEND (g) VALUE ACCORDING TO TABLE ABOVE.

Rossi  a company of the Habasit group www.rossi-group.com		IEC 60334-1 <b>IE1</b> made in Italy	
MOT. 3~ N. 06202/11 01/11	IP 55	AMB. 40°C IC 411	
HBZ 80B4 B5	kg 9.2	I.CL. F S 1 CONT.	
Frano Brake BZ04	Nm 15	V~/Hz 110+480/50+60	A 0,11 RM1 103
Esecuzione Execution <input type="radio"/>			
Δ V Y	Hz	A	kW
230 / 400	50	3.3 / 1.9	0.75
265 / 460	60	3.3 / 1.9	0.75 SF1.15
50Hz IE1 74,7(100%) 74,2(75%) 70,5(50%)			
60Hz NEMA NOM.EFF. 78,5% 1HP DES.C CODE K			

### MOTOR PLATE EXAMPLE TO SPARE PART REQUESTING

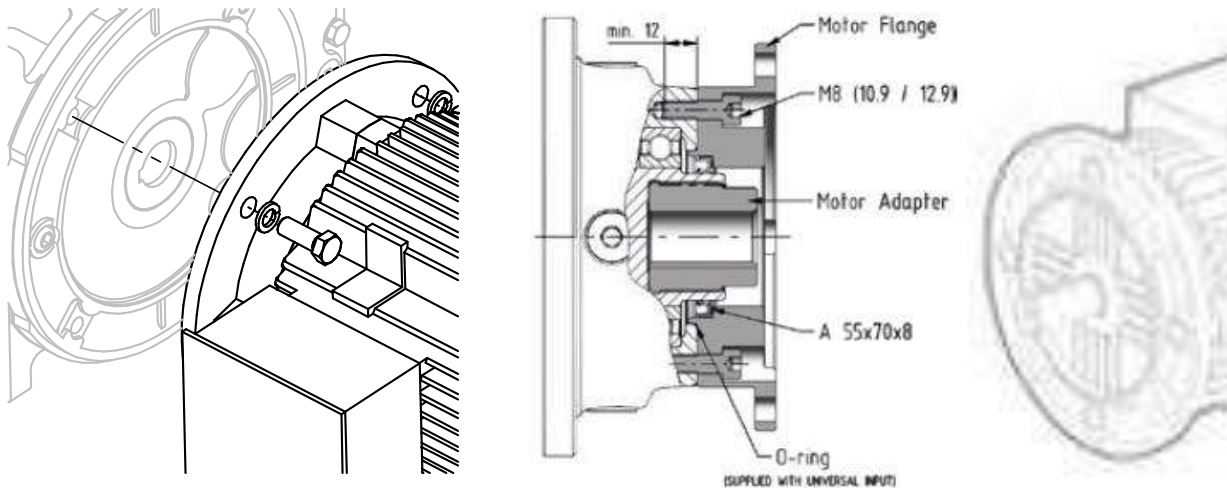
**GEARMOTOR – ELECTRIC MOTOR SUBSTITUTION**

1. Clean motor and gearbox surfaces to be fitting, thoroughly.
2. Mount the parallel key on the motor axel and perform coupling to gearbox hole carefully.
1. Fit motor flange to gearbox flange with screws and nuts.

**PREVENTIVE MAINTENANCE OF MOTOR AND ELECTRIC BRAKE:**

- Keep external surfaces free from oil, dust and machining residuals.
- Keep free all air cooling circuits (housing, air input).
- Check that electric connections are fitted properly.
- Check the correct tightness of the motor and that there are no leaks in the seals.
- Check that motor run is free from vibrations and anomalous noises.

**ATTENTION:**

**TO ORDER SPARE PARTS FOR THE MOTOR OR ELECTRIC BRAKE, IT IS NECESSARY TO REFER TO THE MOTOR PLATE INFORMATION. THAT WAY, SPARE PART SUPPLY ERRORS ARE AVOIDED.**

**INFORMATION:**

**IF YOU REQUIRE TECHNICAL ASSISTANCE FOR GEARMOTOR, YOU CAN CONTACT THE MANUFACTURER, OR THE SERVICE MOTOR MANUFACTURER IN EACH COUNTRY. SEE CONTACT POINTS: <http://www.rossi-group.com>**

**ATTENTION:**

**CHECK IF HOIST IS CONNECTED TO A POWER SUPPLY EQUIPED WITH DIFFERENTIAL PROTECTION 300mA.**

### 5.3. Instructions for troubleshooting.

<b>GEARMOTOR</b>		
<b>Problem</b>	<b>Probable cause</b>	<b>Solution</b>
Motor doesn't work.	Supply line fault. Motor box connection fault. Brake doesn't work. Motor internal fault.	Check 3-phase electric supply. Check motor connection. Check brake s/section. 5.2 Ask to the manufacturer.
Motor can't raise rated load.	Motor connection problem Insufficient voltage supply Supply voltage drop.	Check motor connection. Check supply line. Check supply cross section wire.
Motor overheats.	Motor connection error. Motor locked. Voltage supply error. Fan cover obstructed. Insufficient ventilation air flow. Brake doesn't work.	Check motor connection. Check brake s/section. 5.2 Check supply line. Release air passage to the fan. Check for obstacles to ventilation. Check brake s/section. 5.2
Excessive current consumption.	Brake locked. Motor coil damage.	Check brake s/section. 5.2 Ask to the manufacturer.
Motor brake doesn't release .	Brake connection fault. Rectifier damaged. Excessive brake airgap. Brake coil damaged.	Check motor connections. Check rectifier s/section. 5.2 Check air-gap s/section. 5.2 Check brake coil s/section. 5.2
Brake doesn't hold the load.	Excessive brake airgap. Brake coil damaged. Excessive brake disk wear.	Check brake coil s/section. 5.2 Ask to the manufacturer . Replace brake disk
Excessive brake noise.	Excessive airgap.	Check air-gap s/section. 5.2
<b>GENERAL</b>		
Hoist doesn't run. (OUT OF SERVICE RED LIGHT ON)	There's safety device activated.  Frequency converter error. E1 fault. Phase error.	Check emergencies stop buttons (SE), or safety end track microswitches FCSG. Check frequency converter status. Check electric diagram. Rearm E1. Change supply phase connection.
Hoist moves doing abnormal noise or it doesn't smoothly.	Guide roller damaged. Lack of grease in pinion. Lack of grease in rack	Check and change guide rollers. Check bearings and change if required. Apply grease in pinion and rack.
Hoist slides down when charging loads.	Problem or brake wear. Overload on the cage.	Check brake coil s/section. 5.2 Remove overload.
Hoist doesn't stop in upper/lower limits, or at landing doors.	Problem with magnetic sensor. Problem with end track limit switches.	Check encoder and magnetic ring. Check end track limit switches.
Hoist doesn't stops on 2 m point.	Problem with 2 m. switch or cam.	Check 2 m. end track switch and cam.
E3 or E4 fault.	Problem in control transformer.	Check / Replace transformer.
E2 fault.	Hand tool socket excessive consumption.	Check hand tools socket connection.
E5 fault.	Brake supply rectifier fault.	Check rectifier s/section. 5.2
Hoist stops suddenly.	Overload. Power supply failure. Door open.	Check load on the cage. Check electrical connection. Check landing doors and cage doors.
Cage of the hoist vibrates abnormal.	Non tightened screws. Rack or pinion wear problem. Lack of lubrication. Mast tube tubes wear problem.	Check guide roller s/section. 5.2 Check rack and pinion gear. Lubricate rack and pinion. Check mast for tube wear.
Gearmotor sounds abnormally.	Lack of oil on the motor box. Gearbox bearing failure.	Check oil level and oil leaks. Ask to the manufacturer.
Hoist suffer stops when moving.	Communication cable damaged. End track or door switches unadjusted.	Check communication cable. Check end track limit switches position.
Hoist can't raise rated load.	Cross section wires inadequate. Motor brake damaged. Supply voltage inadequate.	Check supply wire. Check brake s/section. 5.2 Check voltage supply
Hoist doesn't move up or down.	LED panel indication Cage or landing door incorrectly closed	Check indications. Check cage / landing doors.

#### 5.4. Maintenance record.

According to the procedure specified in the user's manual, the responsible for maintenance of the hoist should fill this table according to the frequency indicated, for the record of scheduled tasks.

No.	DATE	TASK DESCRIPTION	NAME	SIGNATURE
1				
2				
3				
4				
5				
6				
7				
8				
9				
10				
11				
12				
13				
14				
15				
16				
17				
18				
19				
20				
21				
22				
23				
24				
25				
26				
27				
28				
29				
30				
31				
32				
33				
34				
35				
36				
37				
38				
39				
40				
41				
42				
43				
44				
45				

No.	DATE	TASK DESCRIPTION	NAME	SIGNATURE
46				
47				
48				
49				
50				
51				
52				
53				
54				
55				
56				
57				
58				
59				
60				
61				
62				
63				
64				
65				
66				
67				
68				
69				
70				
71				
72				
73				
74				
75				
76				
77				
78				
79				
80				
81				
82				
83				
84				
85				
86				
87				
88				
89				
90				
91				
92				
93				
94				
95				

**5.5. Trouble record**

TYPE OF FAILURE: .....

Cause: .....

Reparations performed: .....

.....

.....

PARTS TO CHANGE					
Code	Denomination	Quantity	Code	Denomination	Quantity

ALBA authorized technical person

User

.....

Place .....

Date.....

TYPE OF FAILURE: .....

Cause: .....

Reparations performed: .....

.....

.....

PARTS TO CHANGE					
Code	Denomination	Quantity	Code	Denomination	Quantity

ALBA authorized technical person

User

.....

Place .....

Date.....

TYPE OF FAILURE: .....

Cause: .....

Reparations performed: .....

.....

.....

PARTS TO CHANGE					
Code	Denomination	Quantity	Code	Denomination	Quantity

ALBA authorized technical person

User

.....

Place .....

Date.....

TYPE OF FAILURE: .....

Cause: .....

Reparations performed: .....

.....

.....

PARTS TO CHANGE					
Code	Denomination	Quantity	Code	Denomination	Quantity

ALBA authorized technical person

User

.....

Place .....

Date.....

TYPE OF FAILURE: .....

Cause: .....

Reparations performed: .....

.....

.....

PARTS TO CHANGE					
Code	Denomination	Quantity	Code	Denomination	Quantity

ALBA authorized technical person

User

.....

Place ..... Date.....

TYPE OF FAILURE: .....

Cause: .....

Reparations performed: .....

.....

.....

PARTS TO CHANGE					
Code	Denomination	Quantity	Code	Denomination	Quantity

ALBA authorised technical person

User

.....

Place ..... Date.....

TYPE OF FAILURE: .....

Cause: .....

Reparations performed: .....

.....

.....

		PARTS TO CHANGE			
Code	Denomination	Quantity	Code	Denomination	Quantity

ALBA authorized technical person

User

.....

Place .....

Date.....

TYPE OF FAILURE: .....

Cause: .....

Reparations performed: .....

.....

.....

		PARTS TO CHANGE			
Code	Denomination	Quantity	Code	Denomination	Quantity

ALBA authorized technical person

User

.....

Place .....

Date.....