



www.alba.es

CANOPY BRANDS EUROPE, S.L.U.
Polígono Ind. Bayas c/ Suzana Parc.134
09200 MIRANDA de EBRO (Burgos)
☎ (+34) 947 347 820
✉ : comercial@alba.es ; 🌐 : www.alba.es

RACK & PINION TRANSPORT PLATFORM

PT 450/650

USER GUIDE

- INSTALLATION, USE & MAINTENANCE INSTRUCTIONS
- SPARE PARTS LIST

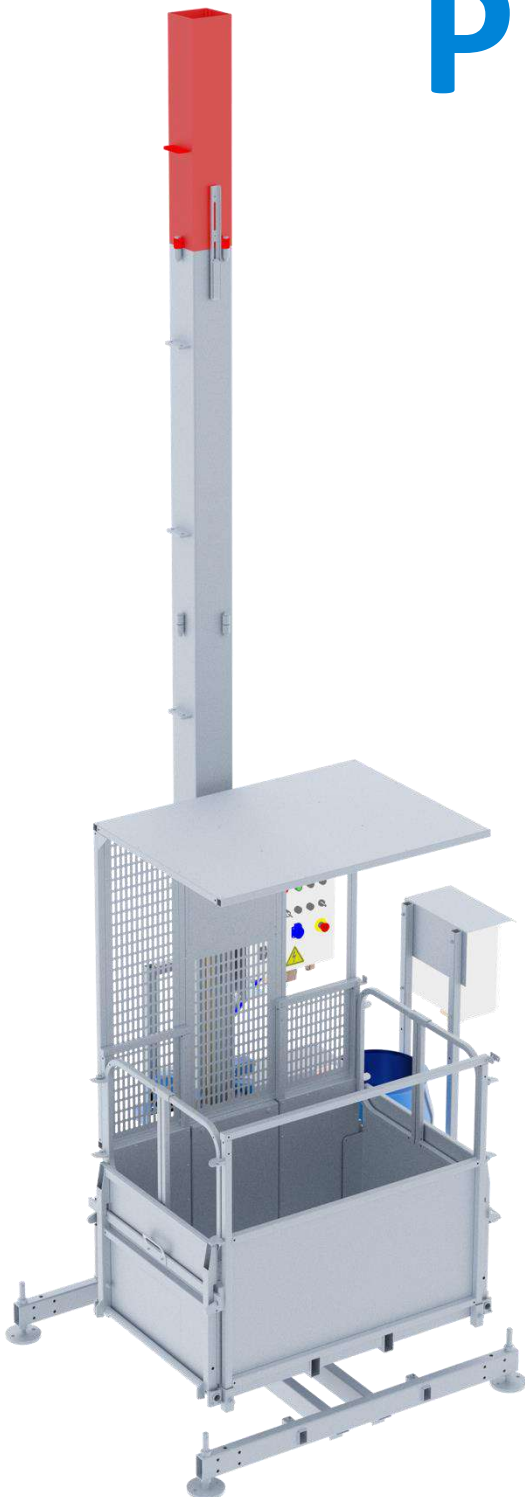

Machine No.:

Model:

Year of manufacture:

Electric connection:

KEEP THIS GUIDE FOR FUTURE REFERENCE

CONTENTS

1. DESCRIPTION OF THE MACHINE	3
1.1 Introduction	3
1.2 General information	4
1.3 Technical data	5
1.4 Main components.....	7
1.5 Main dimensions	9
1.6 Hoist safety devices	12
1.7 Additional data of the hoist	12
2. ASSEMBLY OF THE MACHINE.....	13
2.1 Introduction	13
2.2 Hoist transport.....	13
2.3 Machine erection procedure	15
Step 1 Site preparation and foundation	15
Step 2 Base to ground positioning and fastening	15
Step 3 Assembly of motor group and electric connection	16
Step 4 Erection of the mast	18
Step 5 Installing mast anchorage.....	20
Step 6 Installing end track cams and final mast.....	22
Step 7 Assembly of cable holder	23
Step 8 Installing base enclosure	24
Step 9 Installing landing doors.....	25
· SWINGING DOOR LANDING DOORS (USUALLY TO SLAB).....	25
· SLIDING DOOR LANDING DOORS (USUALLY TO SCAFFOLD).....	27
Step 10 Test of parachute	29
Step 11 Installing landing levels cams	30
Step 12 Programming landing levels	31
Step 13 Installing landing levels call system – OPTION.....	32
Step 14 Installing roof and mast protector.....	34
2.4 Dismantling the hoist.....	36
3. USING THE HOIST	37
3.1 Introduction	37
3.2 Using “MANUAL” Mode.....	38
·A) TRANSPORT PLATFORM PT 450/650-2V	38
·B) TRANSPORT PLATFORM PT 450/650-1V	39
3.3 Using “AUTO” Mode	40
· AUTO MODE – SELECTOR “PERSONS”	40
A) TRANSPORT PLATFORM PT 450/650-2V	40
B) TRANSPORT PLATFORM PT 450/605-1V	41
· AUTO MODE – SELECTOR “ONLY LOADS”	42
3.4 Safety messages in display.....	43
3.5 Emergency lowering	44
3.6 Checking hoist operation before commissioning.....	45
3.7 Notes on the use of -1C platforms (equipped with BATT)	46
3.8 Applications and uses forbidden	46

4. SAFETY DEVICE. PARACHUTE FPC-1000	47
4.1 Introduction	47
4.2 Features	48
4.3 Installing the parachute	49
4.4 Parachute testing	50
4.5 Actions to take if safety device is activated	52
4.6 Replacement of parachute	52
5. MAINTENANCE OF THE MACHINE	53
5.1 DAILY Maintenance	53
5.2 PERIODIC Maintenance schedule	54
5.3 Instructions for troubleshooting	62
5.4 Maintenance record.	63
5.5 Trouble record	65

LOAD WEIGHT CONTROL CALIBRATION INSTRUCTIONS**TEST CERTIFICATE****EC DECLARATION OF CONFORMITY****TÜV-PARACHUTE CERTIFICATE****ELECTRICAL SCHEME****ELECTRICAL PARTS****SPARE PARTS LIST**

The user's manual must be kept in good condition. This document contains 68 pages.
Canopy brands Europe S.L.U. reserves the right of incorporating contents or modifications at any time with the purpose of improving both the machine and the information available on the same.



Copyright © Canopy brands Europe S.L.U.
Rev. 1.5: June 2025

1. DESCRIPTION OF THE MACHINE

1.1. Introduction.

Prior to erection and use, all users must read this manual. A thorough reading is recommended for full compliance with safety regulations.

This manual is delivered with the hoist, and its purpose is to give instructions for proper handling during transportation, erection and maintenance, in compliance with the provisions of EU Directive 2006/42/CE on safe machinery. This instruction manual deals with proper use of the machine as well as proper erection and maintenance.

The manufacturer reserves the right to modify the machine for improvements, so that differences may be found in some manual details. In any case, the manufacturer commits to immediately adapt the manual to the improvements.

Responsibility:

CANOPY BRANDS EUROPE, S.L.U., declines any responsibility for damage caused by improper use of the machine as consequence of non-compliance with the provisions of the present Manual. Specifically declines any responsibility for damages derived from:

- Non-compliance with the provisions of this manual.
- Improper use of the machine.
- The use of non-original spare parts mentioned in the applicable section of manual.
- Modifications introduced without express authorisation from the manufacturer.
- Handling by personnel not trained for this purpose.

Only appointed trained personnel may use the machine and only qualified technical personnel acquainted with the machine may operate on any part of the same.

This manual must be available to the user at any time for any type of immediate consultation. In order to maintain it in perfect conditions, keeping always a copy close to the machine is recommended.

In any case, the manual is aimed at knowledge strengthening and as a reminder for the personnel, who must previously be well trained by engineers or supervisors, who at the same time must be very experienced in this machine operation.

1.1. General information.

It's based on the principle of geared motor transmission to a rack and pinion mechanism. Components are modular and easy to install. It is simple to use and safe for facade work or rehabilitation, significantly reducing the erection time and man-hours.

This machine has been designed for temporary installation on site and must be used by skilled authorised personnel. Its main advantage is the ability to connect different building stories for lifting or lowering materials and persons in a fast and safe way. Below, please find the main points to bear in mind prior to erection and use of the machine.

- The hoist is designed (CE-model) **for transporting persons and loads**, in open cage, travelling with a minimum gap of 0,5 m. from supporting structure, and vertical speed limited to 12 m/min. When using for transport of persons, cage control will be with "hold-to-run" pushbuttons. Platform also can be used for **transporting loads**, with exterior control board (ground) and increased speed to 18 m/min. In each case follow the conditions of use stated in this manual.
- The machine runs vertically, geared to the mast rack and guided with support rollers.
- Machine operation must be carried out by **appointed personnel** trained in transport platform operation, and the instructions to operate the machine safely.
- Travelling on the hoist is allowed only for **authorized passengers**, instructed by the operator appointed to management of the platform.
- For erection, dismantling, maintenance and repair tasks, only **competent and authorised technical personnel**, trained and qualified with practical experience on said operations, are allowed to travel on the hoist.
- The transport platform enables a mode of operation from the outside as hoist only for loads. When using as hoist for loads, loading and unloading operations must be performed by **instruded people**.
- The machine is designed to anchor at appropriate intervals to a supporting structure, as the slabs of the floors of a building, a metallic structure or similar. ALBA include in this user's manual all the information regarding to reaction forces to the structure and to the base ground. It is the responsibility of the responsible technicians on site, to ensure that, both supporting structure and base ground support transmitted loads.

WARNING SYMBOLS:



WARNING:

IMPORTANT SAFETY INSTRUCTIONS DURING INSTALLATION OR OPERATION IS TO BE ENTERED IN TEXT BOXES LIKE THIS, INCLUDING THE WARNING SIGN.

1.3. Technical data.

TECHNICAL FEATURES:

	PT 450-2V	PT 450-1V
Motor control:	FREQUENCY CONVERTER	DIRECT
Maximum capacity:	2 pax + 250 Kg 450 Kg	5 pax 450 Kg
Vertical speed:	12÷17 m/min	17 m/min (50 Hz) 20 m/min (60 Hz)
Cage dimensions (LxWxH):	1.240 x 840 x 2.020 mm	

	PT 650-2V	PT 650-1V
Motor control:	FREQUENCY CONVERTER	DIRECT
Maximum capacity:	4 pax + 250 Kg 650 Kg	7 pax 650 Kg
Vertical speed:	12÷18 m/min	18 m/min (50 Hz) 22 m/min (60 Hz)
Cage dimensions (LxWxH):	1.600 x 1.040 x 2.020 mm	

Maximum height (*):	90 m
Anchorage each (max.):	6 m
Height over las anchorage:	1,5 m
First anchorage height:	4 m
Loading height to ground	400 mm
Mast:	Square tube
Length:	1,5 m
Weight:	39 Kg
Maximum load (assembly):	200 Kg
Reference normative	EN-16719 ; 2006/42/CE
	EN-12518-1

(*) For greater heights, please consult the manufacturer. In case of single-phase power supply, please consult limitations.

ELECTRICAL DATA

	PT 450-2V	PT 450-2VM	PT 450-1V	PT 450-1VM
Motor power:	2,2 KW		2,2 KW	
Input power connection:	3~ 380÷460V 50/60 Hz.	1~ 200÷250V 50/60 Hz.	3~ 400V -50Hz 440V -60Hz	1~ 200÷250V 50/60 Hz.
Power consumption:	4 KW	2,2 KW	2,2 KW 2,65 KW	2,2 KW
Nominal current:	6 A.	13A	6 A.	13A
Supply power:			8 KVA.	
Overload protection (*):	3 x 16 A.		2 x 16 A.	
Differential protection (*)				
Calibre:	25 A.			
Sensitivity:	300 mA.			
Control voltage:	48 V.			
Auxiliary hand tools socket:	230 V – 50/60 Hz. 1200 W.			
Cable section:	4 x 4 mm ²	3 x 4 mm ²	4 x 4 mm ²	3 x 4 mm ²

(*) Elements required on main feed switchboard

	PT 650-2V		PT 650-1V	
	50/60 Hz		50 Hz	60 Hz
Motor power:	2x 1,5 KW		2x 1,5 KW	2x 1,8 KW
Input power connection:	3~ 380÷460V 50/60 Hz		3~ 400V -50Hz	3~ 440V -60Hz
Power consumption:	4 KW		3 KW	3,6 KW
Nominal current:	9,5 A		7,5 A	7 A
Supply power:	10 KVA		8 KVA	
Overload protection: (*):	4 x 16 A		4 x 10 A	4 x 10 A
Differential protection (*)				
Calibre:	16 A		10 A	10/16 A
Sensitivity:	300 mA		300 mA	300 mA
Control voltage:	48 V			
Auxiliary hand tools socket:	230 V – 50/60 Hz 1200 W			
Cable section:	4x 4 mm ²		4x 4 mm ²	

(*): Elements required on main feed switchboard

ACOUSTIC DATA

A-weighted emission sound pressure level, LpAd

<70dB

Place: Operation point

1.4. Main components.

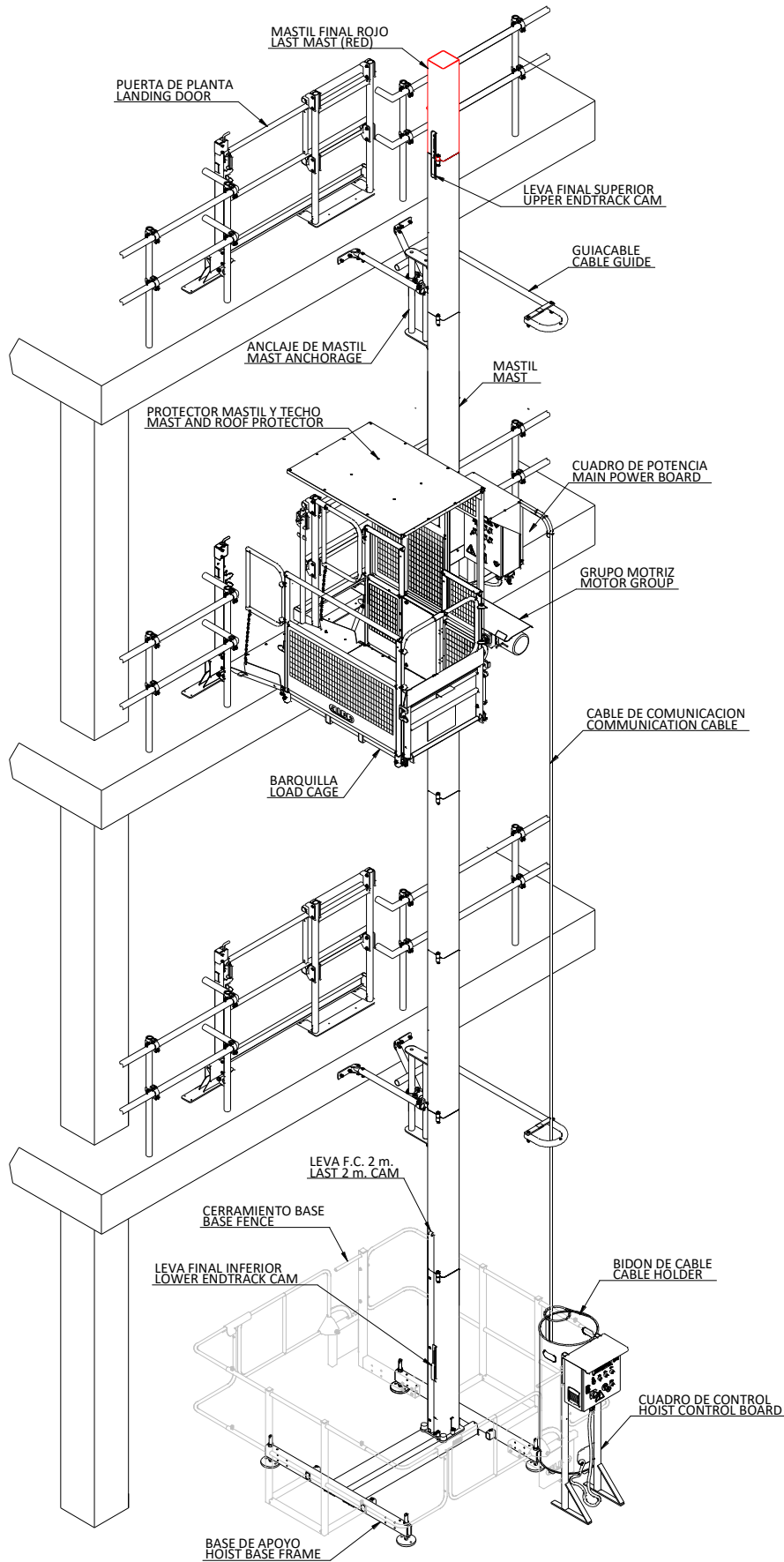

ASSEMBLY EXAMPLE. TRANSPORT PLATFORM PT450/650

- MAST BASE SUPPORT:**
 Main structure that is used as a support for the hoist and for the column of masts. It transmits the efforts generated to the ground and it's surrounded with a safety enclosure that avoids the risk of damage. The base incorporates absorbers to avoid blows of the car with the base. In the base of the machine is the electrical switchboard for electrical supply.
- MAST:**
 Modular structure for the ascent of the machine. It consists of a modular triangle structure of 1,5m. The mast has a welded rack for the movement of machine. They are designed for his union by means of bolts, and for the anchor to a vertical structure to intervals.
- DRIVE UNIT:**
 Structure that incorporates and the system of motor gear system and that provides the movement to the elevator. It incorporates both the motor gears and the safety systems to control the movements, overload system, and the floor selector. It fits the car with bolts.
- CAGE:**
 Metallic open structure for the transport of persons and loads. It includes doors for the loading and unloading of the machine, and auxiliary catwalk for assembly operations, all of them equipped with safety microswitches.

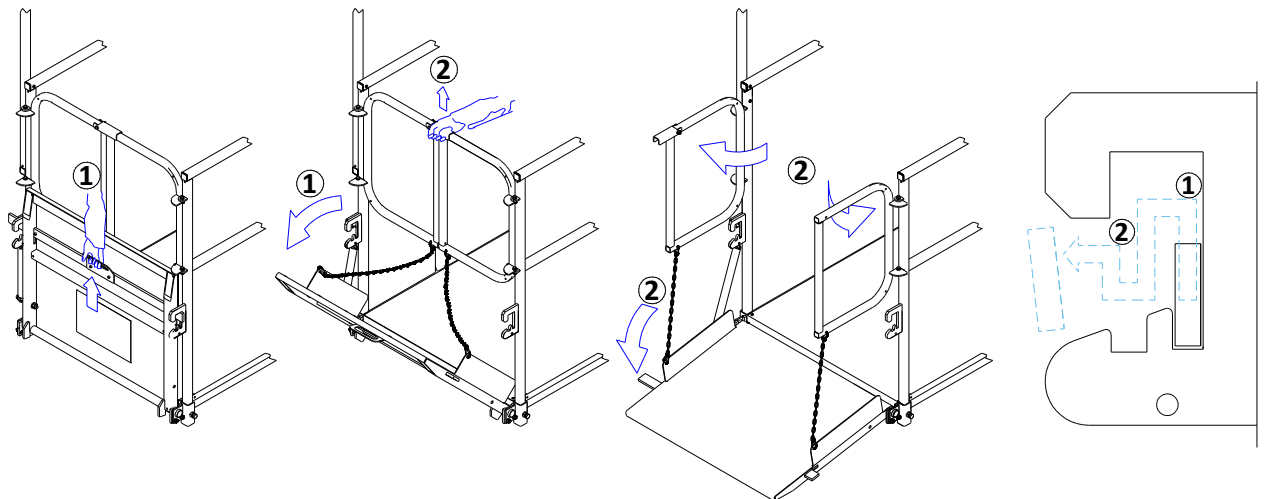

- ANCHORAGE:**
 System of mast anchor to an external support structure. It consists of a bracket screwed to and a pair of telescopic pipes for adjusting to external support structure.
- CONTROL PANEL:**
 It contains the electrical equipment of the machine and communicates the car control panel and power supply control panel on the ground with proper connectors.
- CABLE DRUM:**
 Keep the cable of the machine during the movement. The cable bin stores the communication cable coiling it.
- END MAST MODULE:**
 Mast module without rack that is installed in the top limit of the column of masts. It prevents the machine from exceeding the top. It's red color for immediate identification.

1.5. Main dimensions.

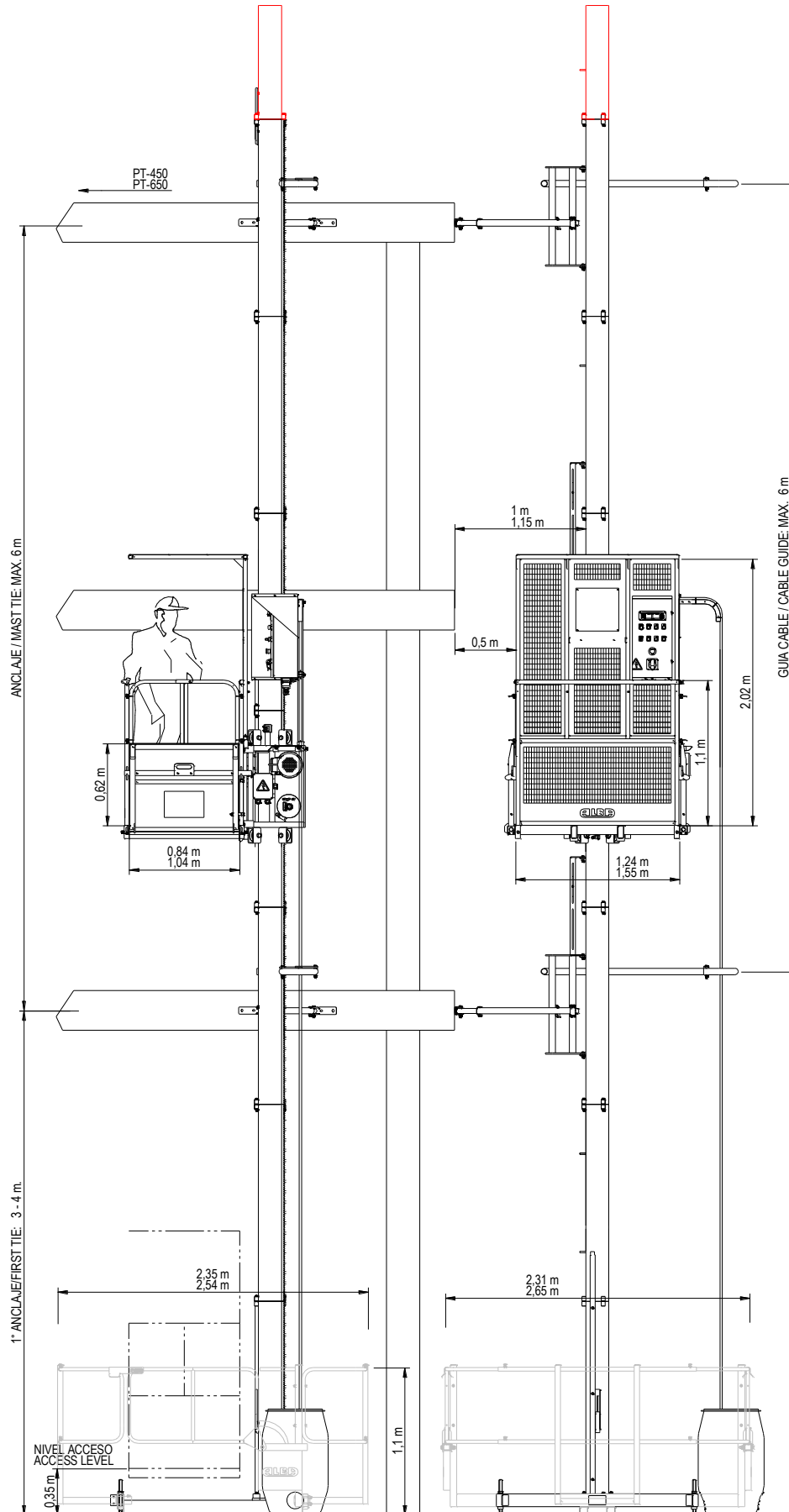

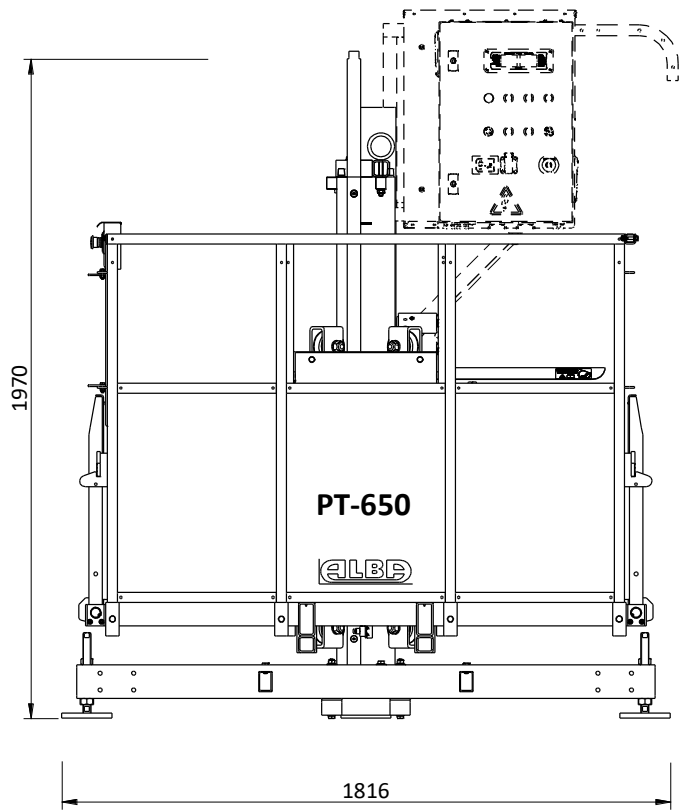
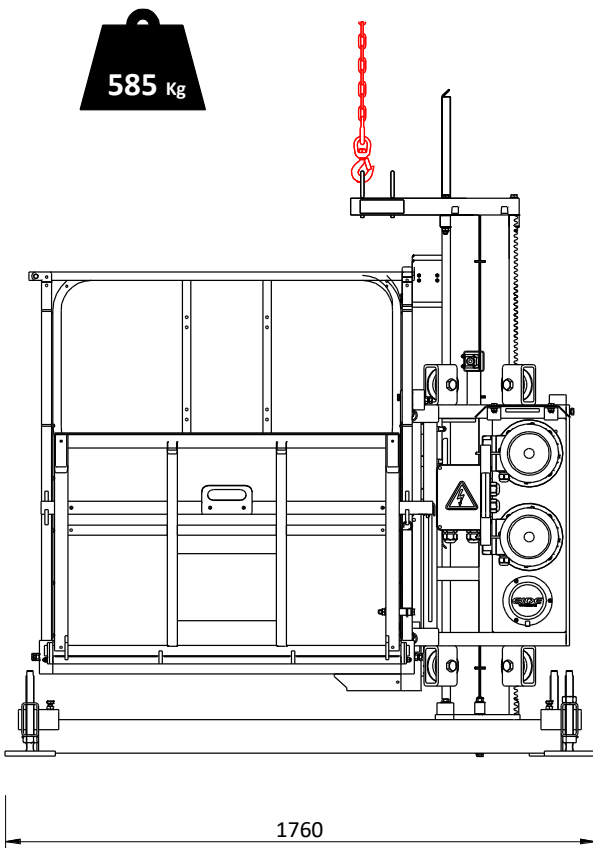
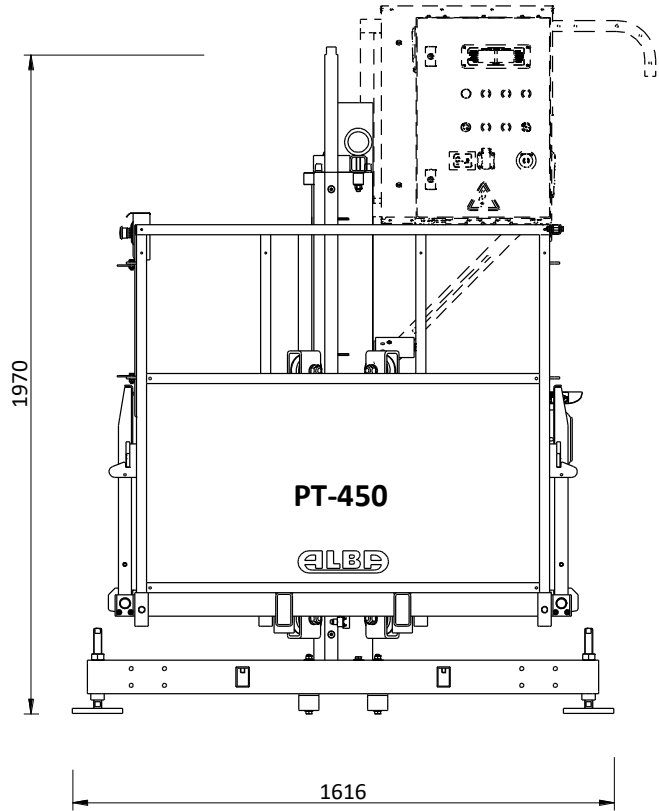
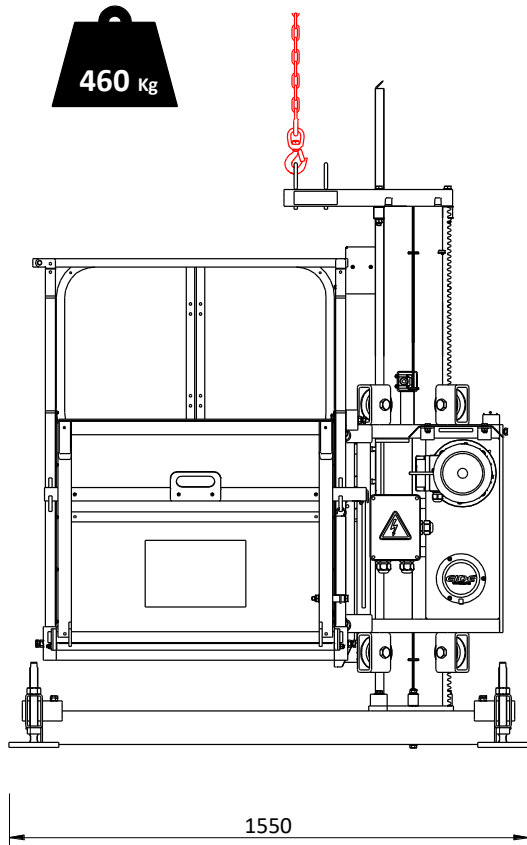

MAIN DIMENSIONS. TRANSPORT PLATFORM PT 450/650

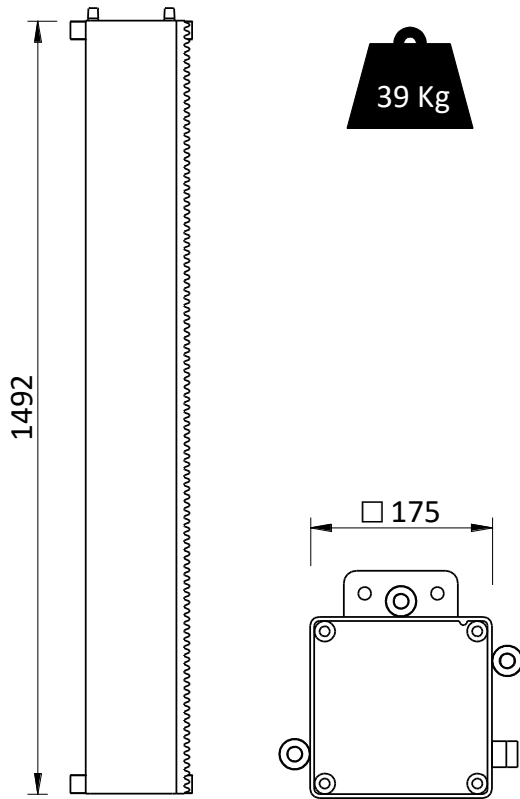

MAST 098.2

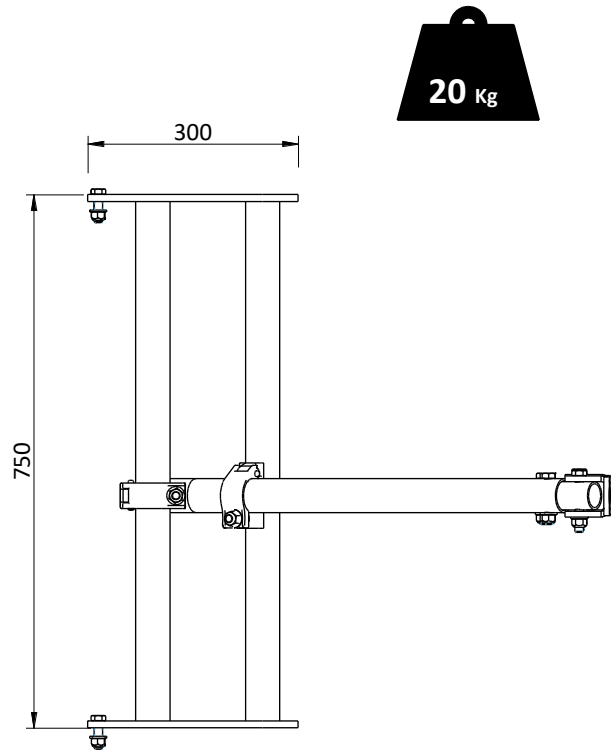

ANCHORAGE SET 162.8x

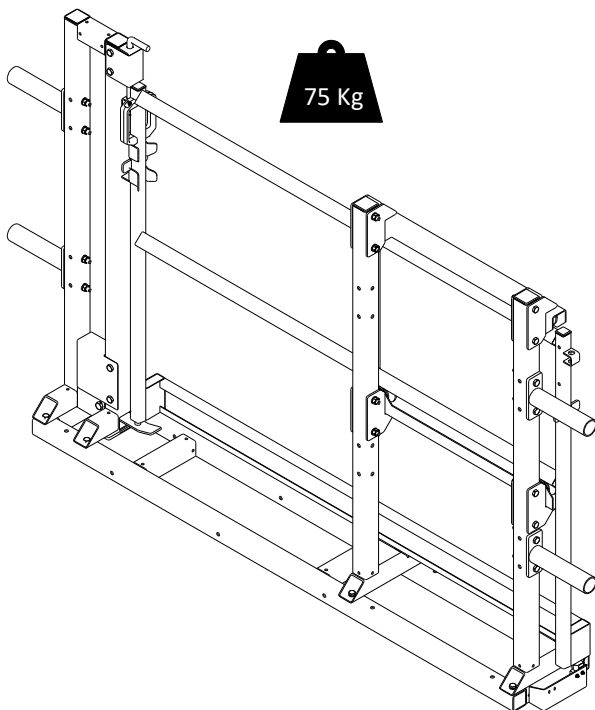

SLIDING LANDING DOOR

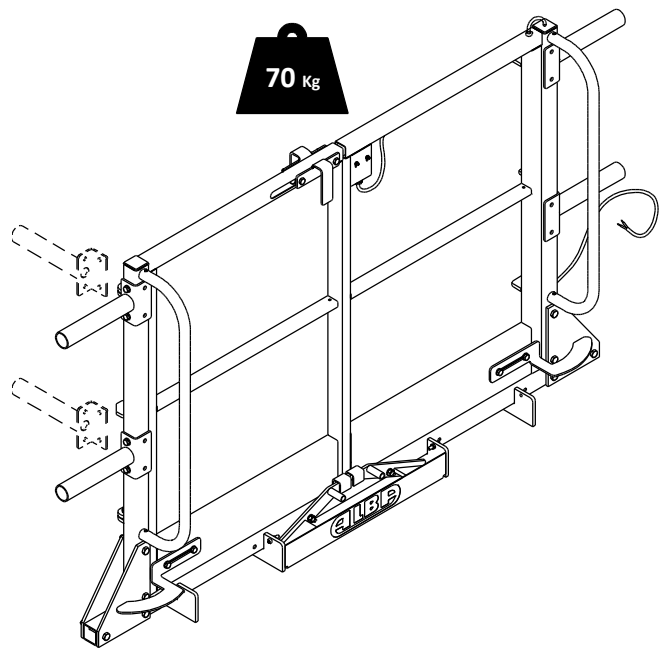

SWINGING LANDING DOOR

1.6. Safety devices of the hoist.

- a) Gearmotors with **electromagnetic brakes** (friction type) capable to brake speeds of 20 m/min. (and even 25% overspeed) with a delay of 0.1 up to 0.2 g. with maximum load.
- b) Rubber buffers to damp eventual frame impacts against the base.
- c) Cage roof finished in hot galvanized steel.
- d) Upper and lower limit switches. Stop the lowering and lifting movements of the cage when reaching the lower and upper stops located at the first and next to last masts.
- e) Safety limit switch. Operate in case of failure of upper or lower limit switches.
- f) Mast presence detector, to be used mainly during mast erection.
- g) Microswitches for opening the cage doors, and for landing doors with mechanical interlocking device.
- h) Unload ramps with automatic bridge and lateral protection railing included, for safety opening from the inside/outside of cage.
- i) Landing doors interlock prevents opening unless the cage is on landing level and ramp is opened.
- j) Limit switch to stop at 2 m elevation. Movement under-2m with "hold-to-run"
- k) **Manual Emergency lowering** in case of power failure (operated from the cage).
- l) **Safety device (Overspeed emergency brake -PARACHUTE-)**, to control the lowering speed.
- m) Base enclosure of 1,1 m height, with a distance to any moving part of the hoist of 0,5 m. and microswitch to prevent platform movements if enclosure door is open.
- n) Platform floor of non-slipping galvanized steel.
- o) End mast (in red), without rack, to prevent the cage from running off in case of failure of other systems.

1.7. Other data of the hoist.

NOISE EMISSION DECLARATION

	Condition
	Outside cage
A-weighted emission sound pressure level, L_{pA}:	71 dB
Uncertainty K_{pA}	3 dB

Values determined according to the acoustic test given in EN 12158-1 with use of basic international standards EN ISO 3744 y EN ISO 4871.

Note:

Noise emission values and uncertainty represent an upper limit of the range in which the measured values are susceptible to be present.

Temperature range for use:	-15°C – 45°C
Relative humidity:	30 % – 90 %
Max. height for installation:	1000 m (**)
Max. wind speed (SERVICE):	55 Km/h
Max. wind speed (ERECTION):	45 Km/h
Max. wind speed (OUT OF SERVICE *):	130 Km/h

(*) Position OUT OF SERVICE corresponds with hoist at the lowest point and power supply disconnected.

(**) For installation in locations above 1000 m of height., and if the temperature exceeds 45° C, ask to manufacturer for limitations.

1. ASSEMBLY OF THE MACHINE

2.1. Introduction.

The following section is dedicated to the safely assembly of the machine. The installation of the hoist can only be performed by qualified personnel authorized to travel on it.

**WARNING:**

TO MOUNT THE ELEVATOR SHALL BE USED PROTECTIVE EQUIPMENT AGAINST FALLS FROM HEIGHT (ACCORDING TO EN 358, EN 361, EN 364) AND IN ANY CASE A PROTECTIVE HELMET FOR THE HEAD (ACCORDING TO EN 397), PLUS ADDITIONAL MEANS OF PROTECTION.



It is important to follow the instructions in detail, to avoid risks in the assembly and disassembly process. The user is obliged to observe, by himself, and for those working in the vicinity, all sources of additional risk, and to comply with all applicable safety standards for the type of equipment used.

2.2. Hoist transport and coupling.

The hoist is supplied unmounted, unless specifically indicated otherwise. For the coupling of main components of the hoist it's necessary to use a crane.

**IMPORTANT:**

TO ASSEMBLE THE COMPONENTS AND THE ASSEMBLY WILL USE A TRUCK LIFT CRANE, OR IF AVAILABLE, ALSO A TOWER CRANE CAN BE USED FOR IT.



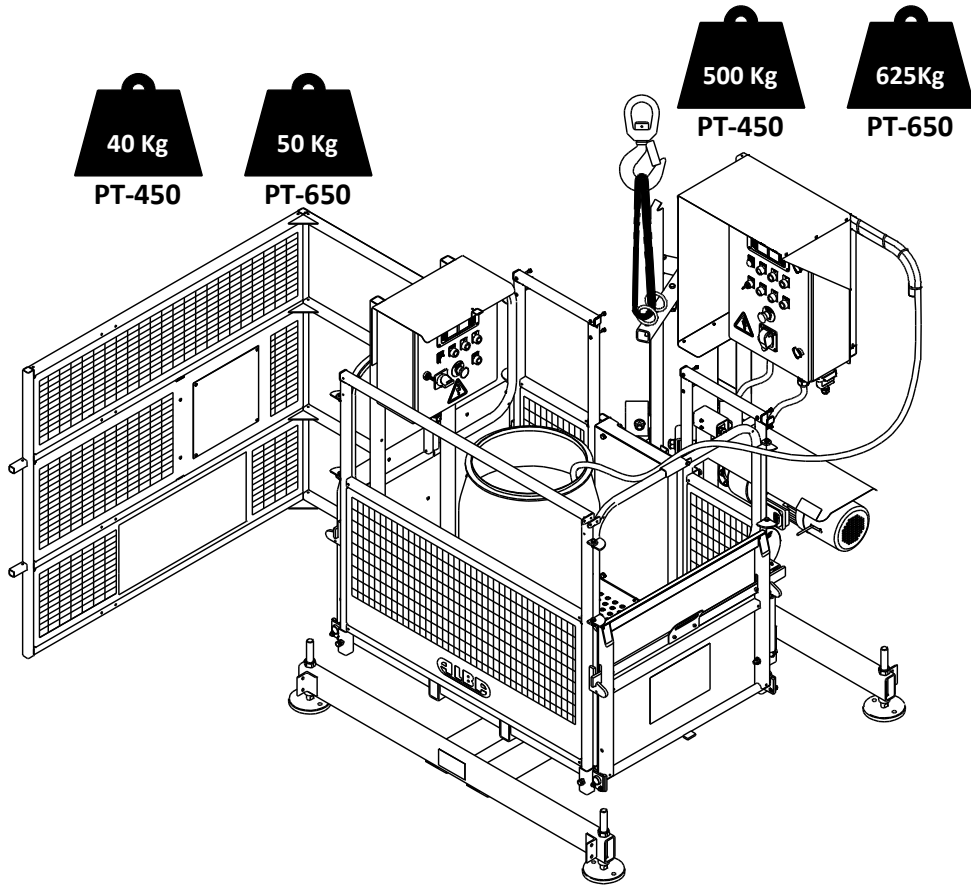

ASSEMBLY OF CAGE. USE A CRANE OR FORKLIFT

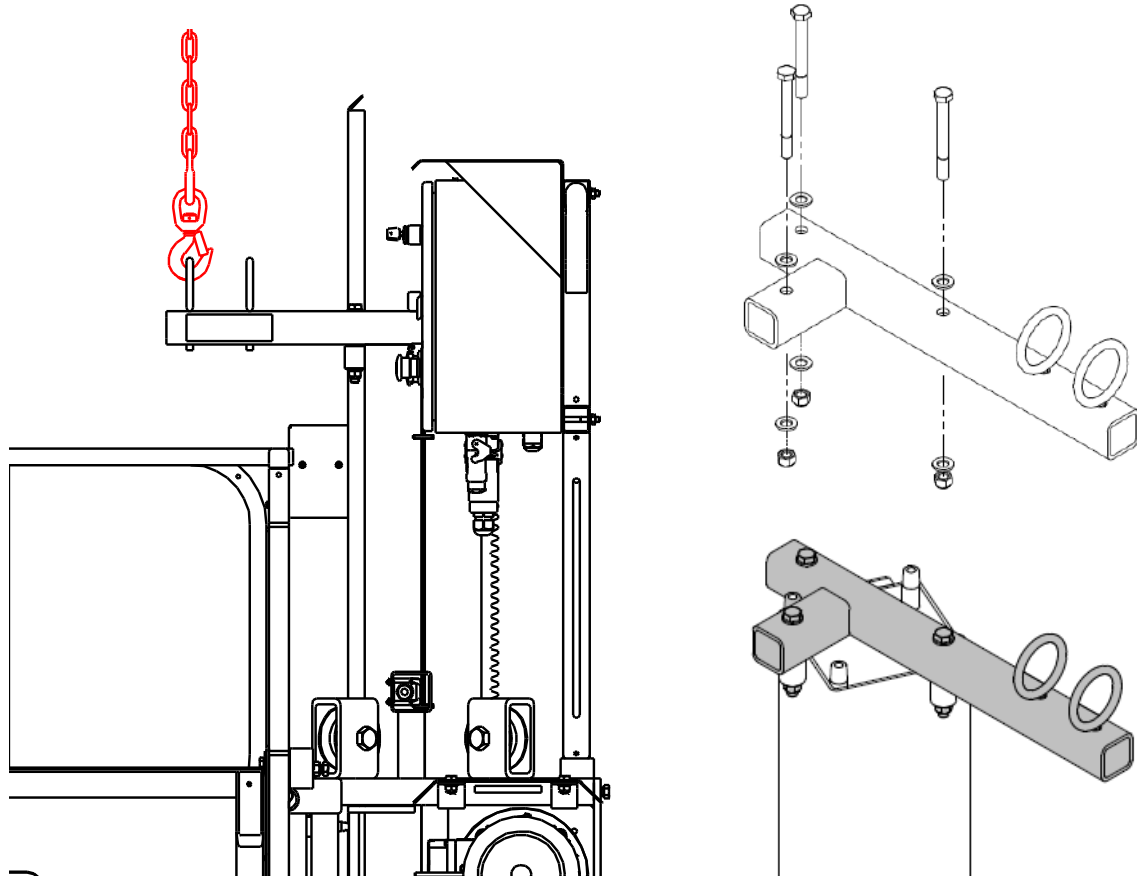

TRANSPORT HOLDER Ref. 099.18

2.3. Machine erection procedure:

- **Step 1. Site preparation and foundation**

TRANSMISIÓN DE CARGAS AL SUELO PT-450		
Altura [m.]	CARGA TOTAL (EST.) [KN]	CARGA TOTAL (DIN.) [KN]
10	12,07	17,90
20	14,62	20,45
30	17,17	23,00
40	19,72	25,56
50	22,27	28,11
60	24,82	30,66
70	27,37	33,21
80	29,92	35,76
90	32,47	38,31

(x225) = [lbf]

TRANSMISIÓN DE CARGAS AL SUELO PT-650		
Altura [m.]	CARGA TOTAL (EST.) [KN]	CARGA TOTAL (DIN.) [KN]
10	15,35	23,42
20	17,90	25,97
30	20,45	28,52
40	23,00	31,07
50	25,56	33,62
60	28,11	36,17
70	30,66	38,72
80	33,21	41,28
90	35,76	43,83

(x225) = [lbf]

(*) For intermediates, add 35 kg/m 23,5lb/ft to table above.

- **Step 2. Base to ground positioning and fastening.**

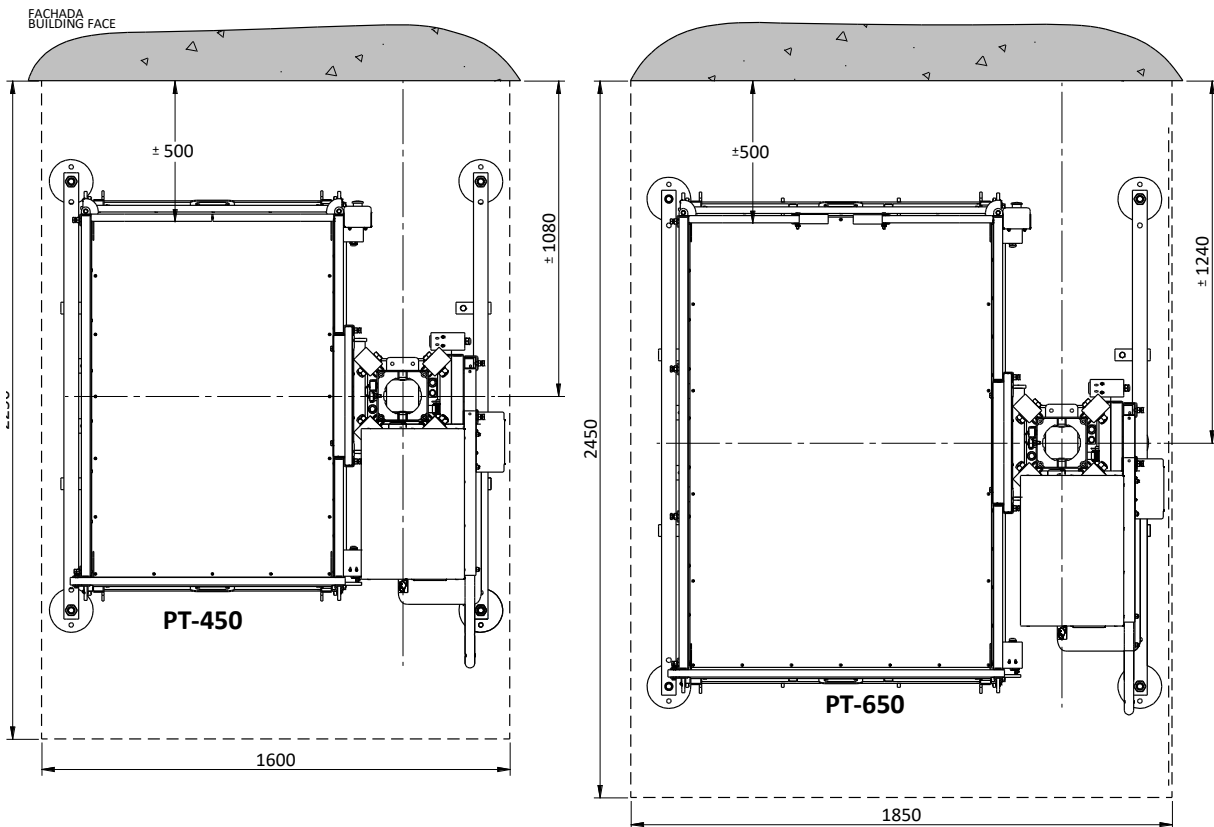

POSITIONING THE HOIST ON THE GROUND

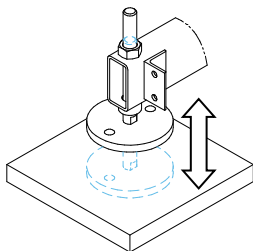

BASE JACKS TO SOIL

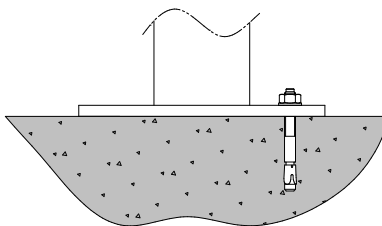
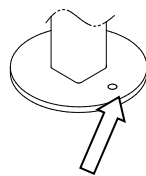

FITTING TO GROUND RECOMENDATION

INSTALLATION DATA

D _o	Drill diameter	10 mm
H ₁	Minimum drill depth	70 mm
H _{nom}	Min. mounting depth	42 mm
L	Anchor length	50 mm
L _r	Screw length	30 N·m

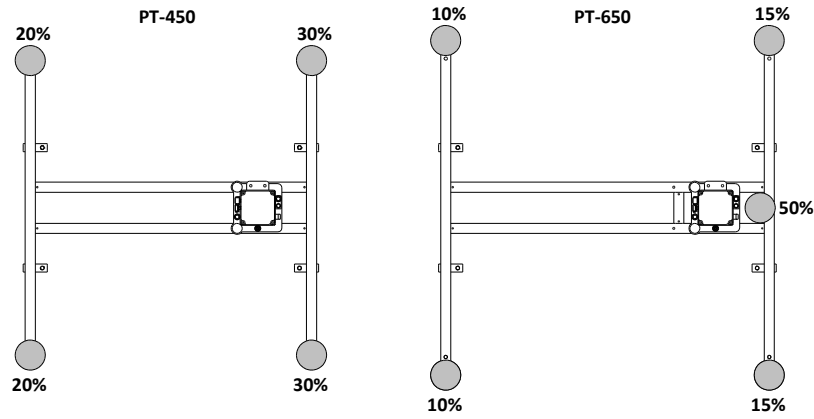

LOAD DISTRIBUTION ON JACKS

⚠ ATTENTION:
MAKE SURE THE RESISTANCE OF THE GROUND TO WITHSTAND THE MAXIMUM LOADS TRANSMITTED BY THE PLATFORM.

- Step 3. Assembly of motor group and electrical connection.

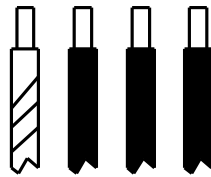
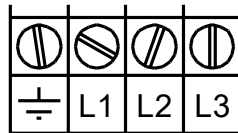
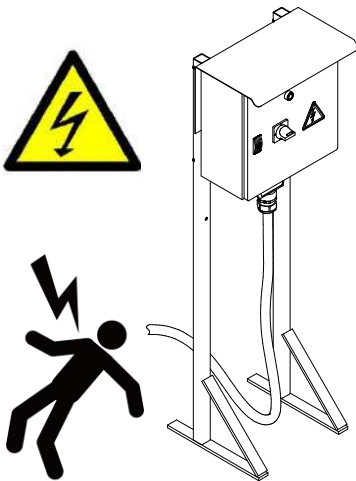

3~ 380/480V, 4mm²

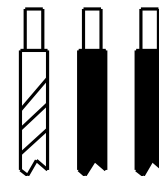
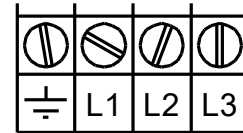

1~ 200/240V, 4 mm²

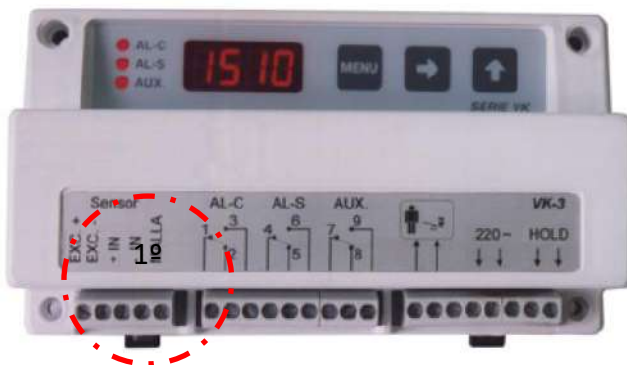

CONNECTING LOAD CELL

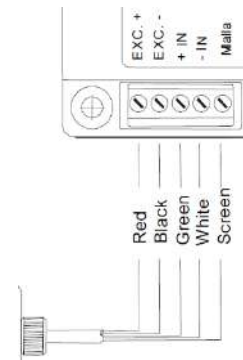

⚠ ATTENTION:
CONNECT ELECTRICAL EQUIPMENT TO MAIN SWITCHBOARD, WITH SPECIAL ATTENTION TO LOAD CELL CONNECTION TO THE PROGRAMER.
PLEASE, CONSULT THE SPECIFIC INSTRUCTIONS FOR ADJUSTING THE LOAD DETECTOR PARAMETERS ON ANEX AT THE END OF THIS MANUAL.
ONCE THE BASE GROUP IS INSTALLED, ACCORDING WITH PREVIOUS INSTRUCTION HOIST CAN BE RUN UP FOR MAST COLUMN ERECTION.

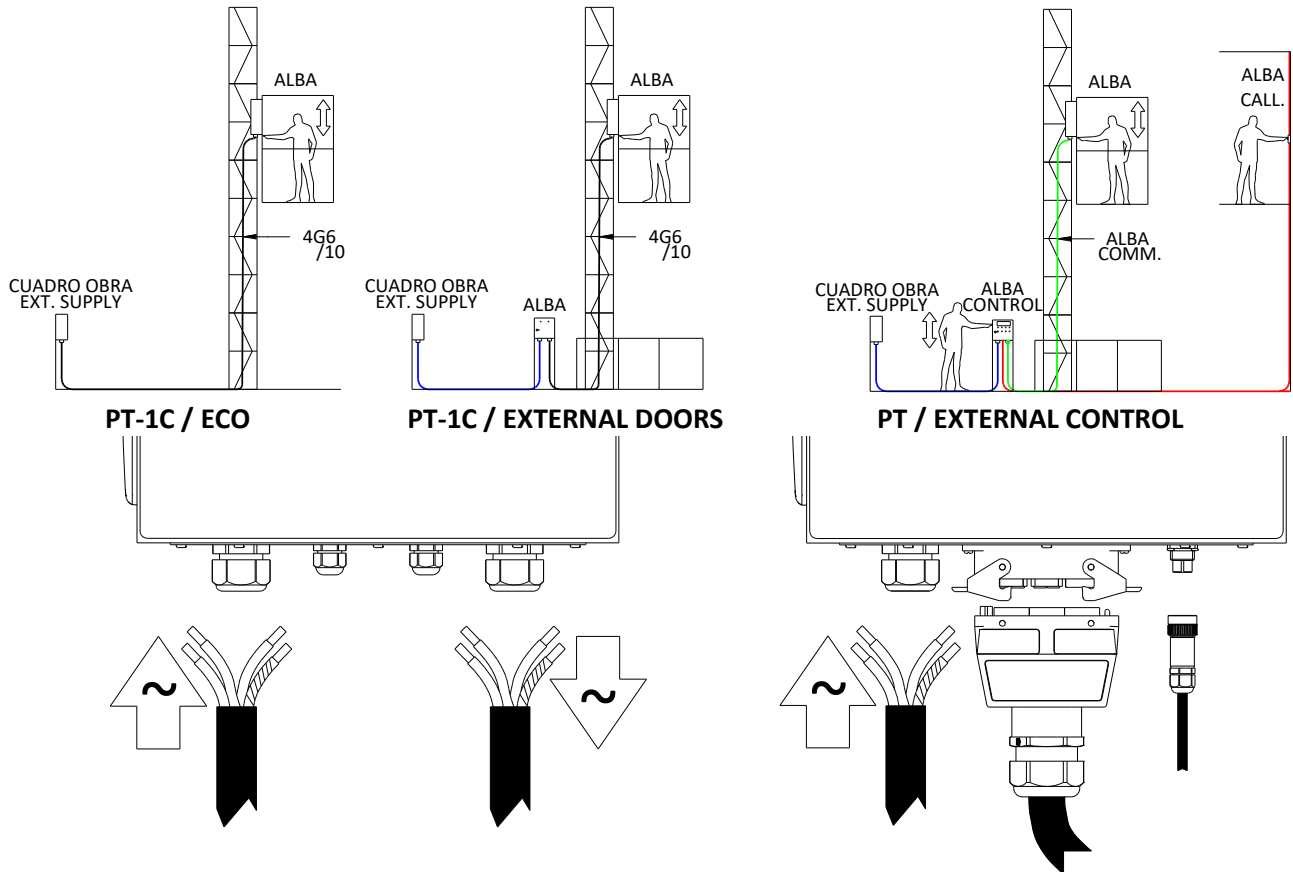

GROUND PANEL POWER SUPPLY AND CONNECTION

• Step 4. Erection of the mast.



ATTENTION:

TO ASSEMBLE THE MASTS WILL USE, PREFERABLY A BUILDING SITE CRANE, OR AN AUXILIARY DAVIT (OPTIONAL). NEVER MANIPULATE THE MASTS BY HAND. IT'S RECOMMENDED TO MOUNT SECTIONS OF 6 M [20 ft] (=4 MODULES) ON THE GROUND AND FASTEN THE WHOLE GROUP TO THE MACHINE WITH THE HELP OF A CRANE. THE FIRST MAST OF THE MACHINE, COUPLED TO THE BASE FRAME, INCLUDES THE NUMBER ID OF THE MACHINE.

MAST TÉCNICAL DATA

Weight: 39 Kg

Rack union:

Welded

Mast screws:

(3x) Screw M12x90 DIN 931 8.8

Washer A13 DIN 125

Self-locking nut M13 DIN 985

Torque (max):

85 N·m

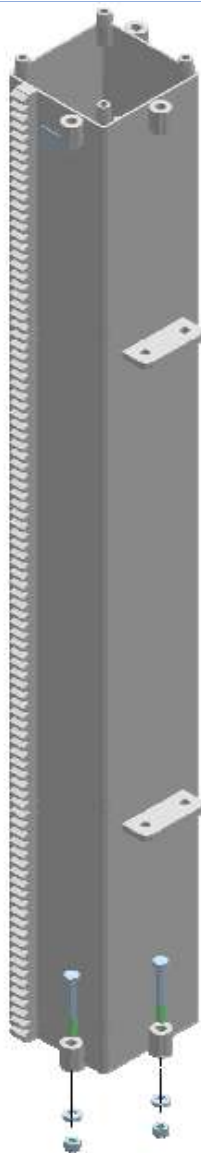

IMPORTANT:

TO MOUNT THE MACHINE, AND FOR INSPECTION AND MAINTENANCE TASKS, ALWAYS USE THE "MANUAL" MODE OF OPERATION (CAGE CONTROL). SEE CHAPTER 3 BEFORE STARTING HOIST ERECTION.

ii MAST ERECTION IN "AUTO" MODE IS NOT ALLOWED!

INSTALL FIRST ANCHOR UP TO 4 M OF. IF IT'S NOT POSSIBLE, ASK THE

MANUFACTURER.

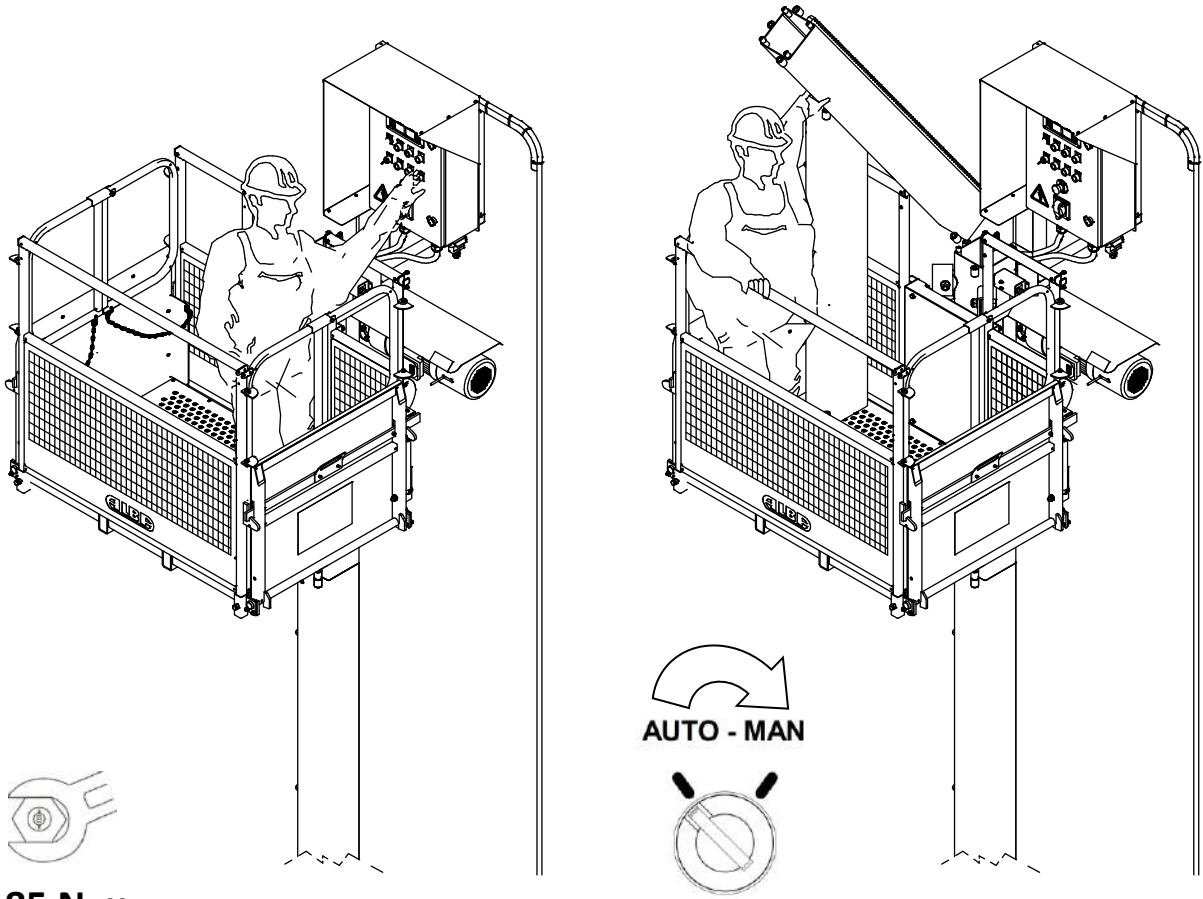

AUTO - MAN

85 N·m

MANUAL ASSEMBLY OF THE MASTS COLUMN

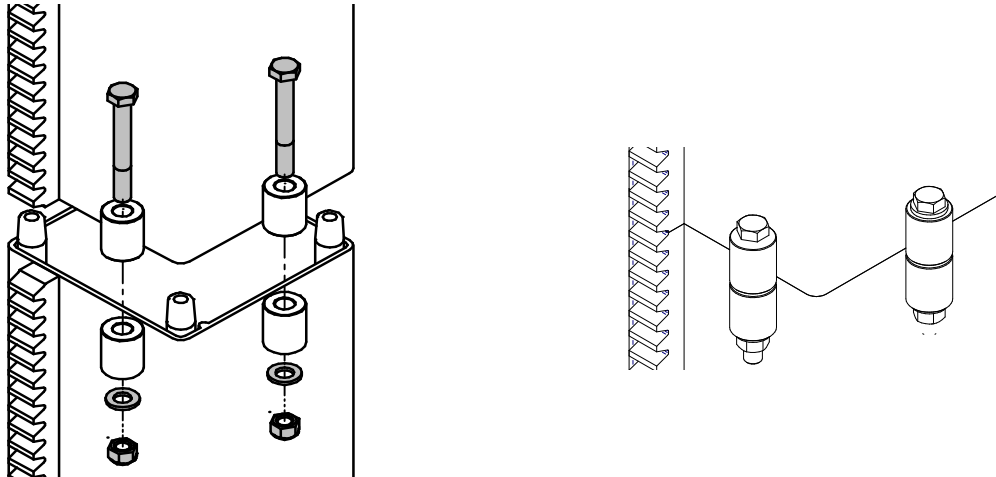

MAST JOINTS



ATTENTION:
FIT / REMOVE MAST AND SCREWS ALWAYS AT THE SAME TIME!
NEVER RAISE THE HOIST OVER A NON-SCREWED MAST MODULE!
THEN THERE IS HAZARD OF COLLAPSE AND SERIOUS INJURY!

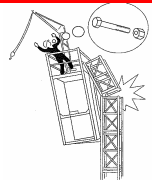

ATENCIÓN:
IT IS IMPORTANT THAT THE BASE IS PERFECTLY LEVELED AND MAST CORRECTLY VERTICAL. ENSURE LEVELING TO AVOID FUTURE PROBLEMS.

• Step 5. Installing mast anchorage.

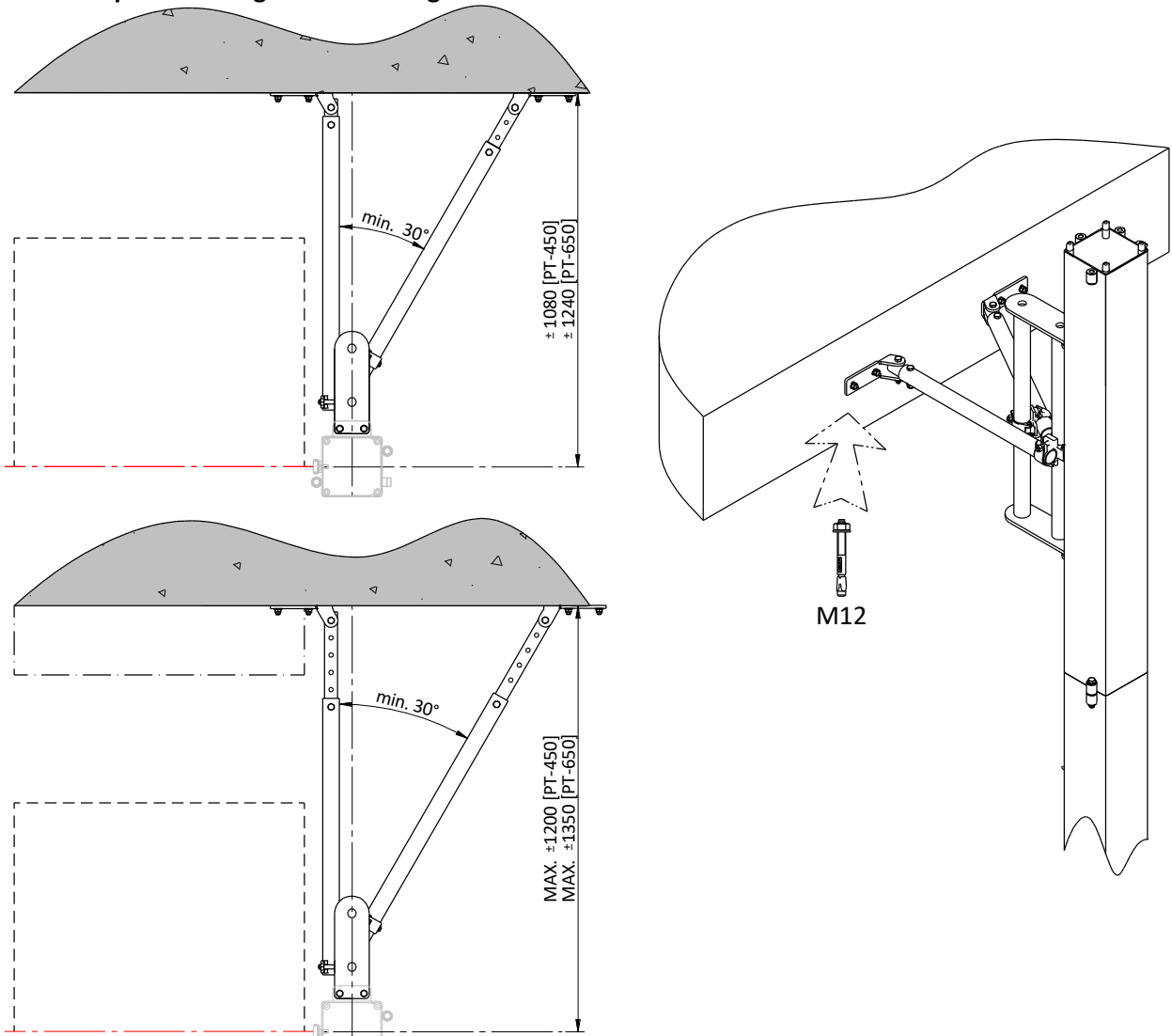

ASSEMBLY ANCHORAGE

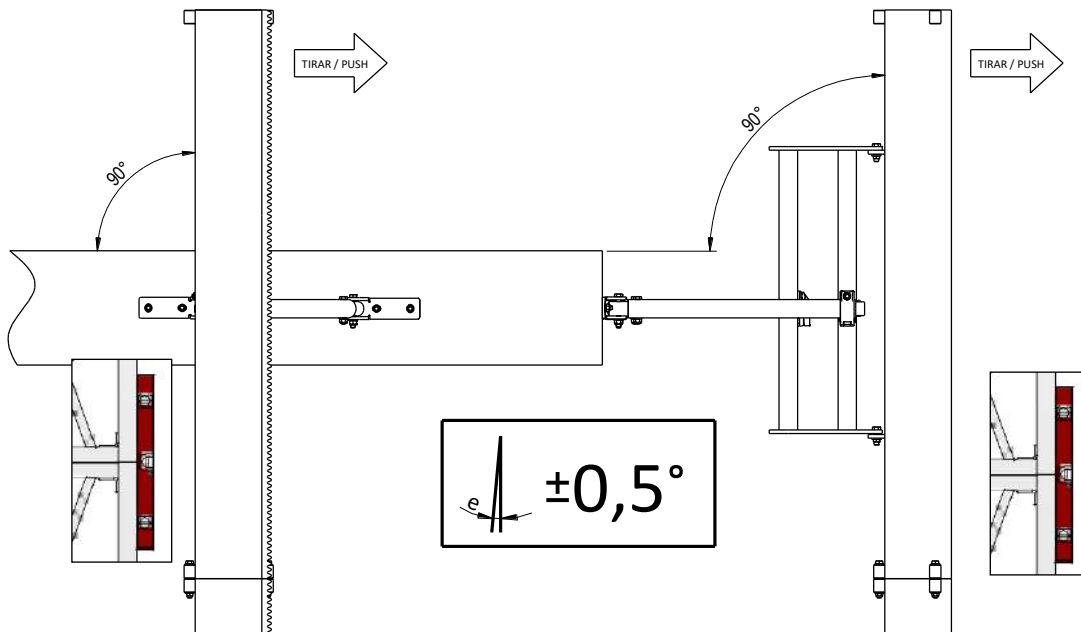

FIXING TO THE SUPPORTING STRUCTURE

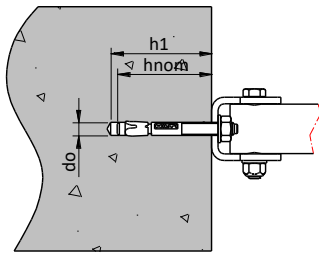

INSTALLATION DATA		
D _o	Drill diameter	12 mm.
H ₁	Minimum drill depth	95 mm.
H _{nom}	Minimum mounting depth	80 mm.
L	Anchor length	120 mm.
L _r	Screw length	65 mm.
T _{ins}	Torque	50 N·m

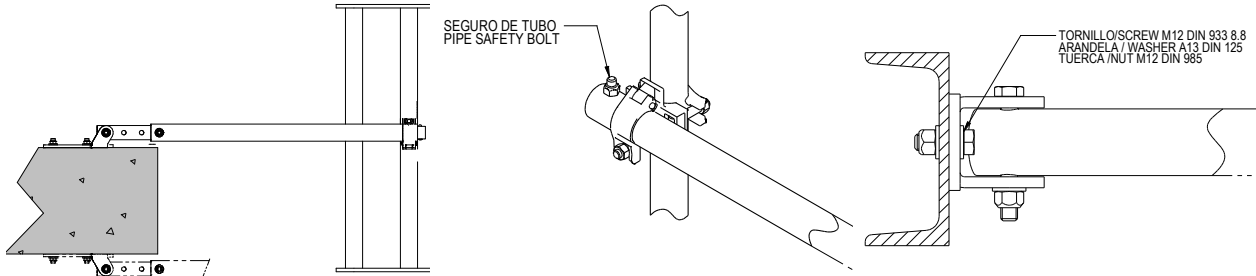
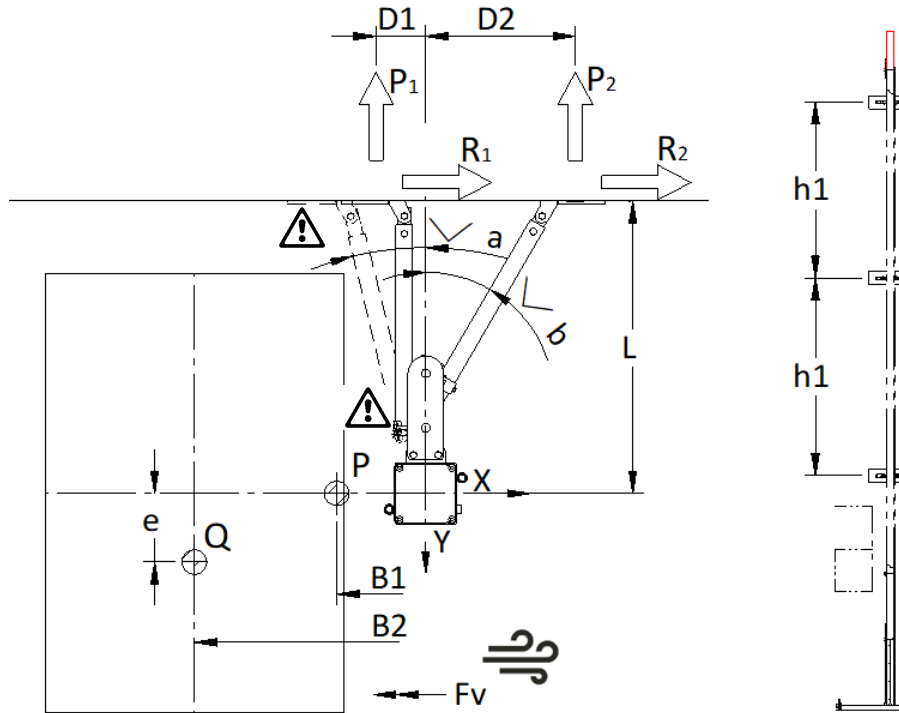
RECOMMENDED ANCHORAGE SYSTEM

INSTALL. ABOVE/BELOW SLAB
**TO VERTICAL TUBES/SCAFFOLD
ALTERNATIVE ANCHORAGE SYSTEMS**
SCREWED TO STRUCTURE

ANCHORAGE INSTALLATION DISTANCES ($V_a=0^\circ$, $V_b=30^\circ$)

	L (mm)	D1 (mm)	D2 (mm)
PT-450	1080	150	625
PT-650	1240	150	725

STANDAR ANCHOR

	L (mm)	D1 (mm)	D2 (mm)
PT-450	1200	150	700
PT-650	1350	150	775

EXTENDED ANCHOR
MAXIMUM REACTION FORCES ($V_a=0^\circ$, $V_b=30^\circ$)

	P1 [KN]	P2 [KN]	R1 [KN]	R2 [KN]	P1 [KN]	P2 [KN]	R1 [KN]	R2 [KN]
PT-450					PT-650			
$h_1 = 6\text{ m}$	2,84	-2,57	0	1,81	5,52	-4,70	0	2,94

ATTENTION:

CHECK POSSIBLE HOIST-ANCHOR INTERFERENCE POINTS BEFORE ANCHORING TO STRUCTURE. MOVE ANCHOR POINT IF NECESSARY.

IMPORTANT:

TRANSMITTED FORCES TO THE STRUCTURE DECREASE WHEN INSTALLATION ANGLE AND DISTANDE "D" ARE INCREASED.

SEPARATE ANCHORAGE PLATES FROM EACH OTHER TO REDUCE TRANSMITTED LOADS TO STRUCTURE IF NECESSARY. CONSULT THE MANUFACTURER THE VALUES OF REACTIONS TO THE STRUCTURE RESULTING.

- Step 6. Installing end track cams and final mast.

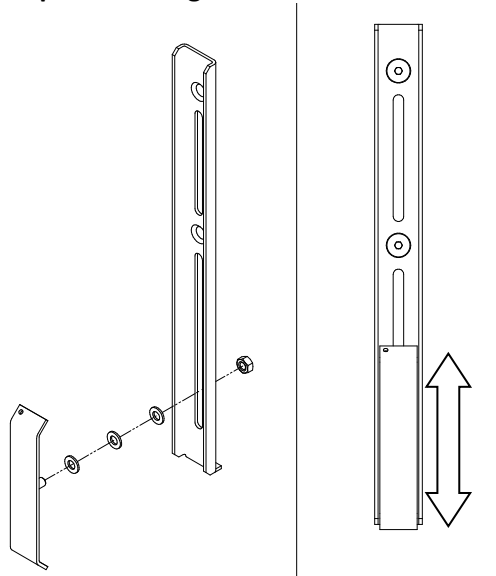
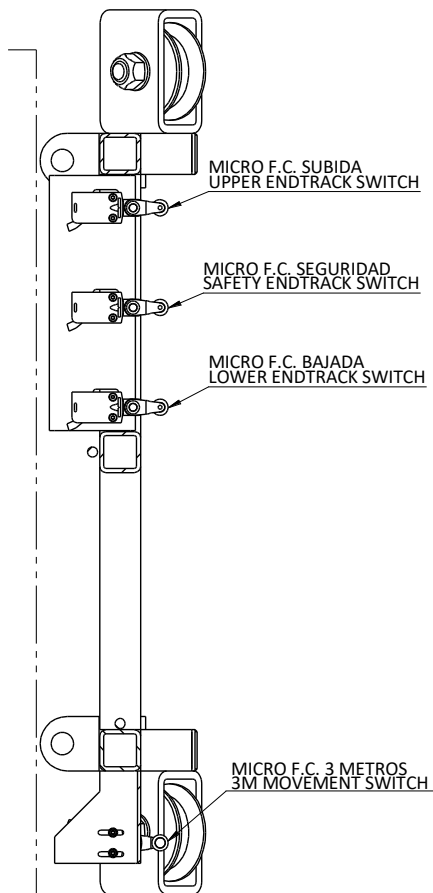
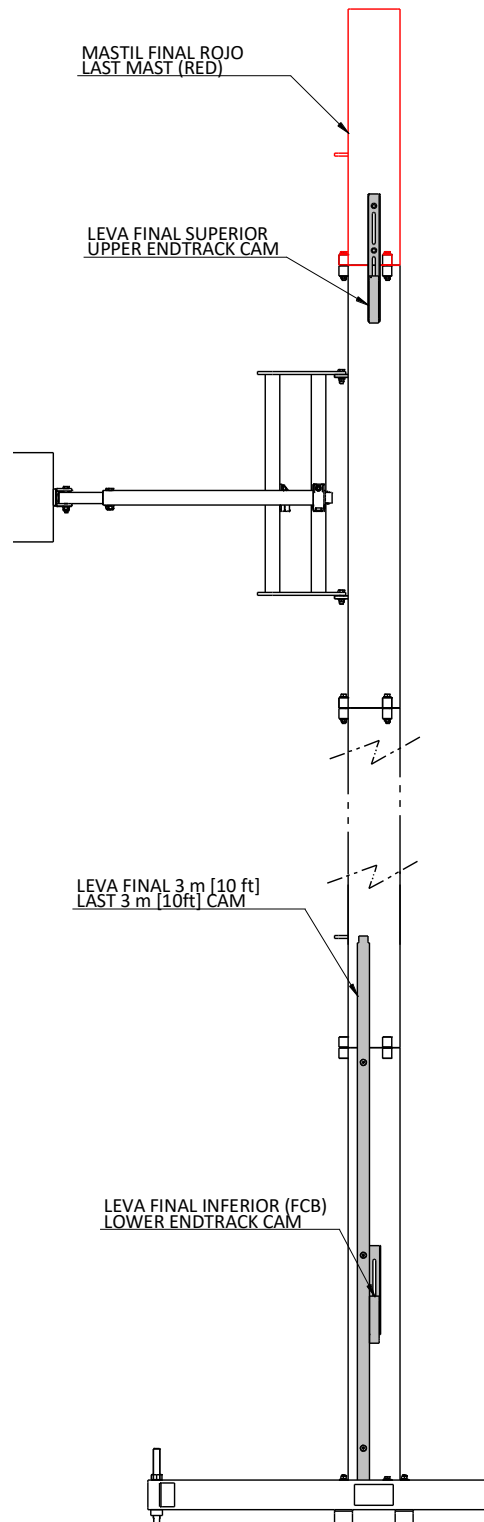
ADJUSTING ENDTRACK CAM

LAST 2M SWITCH

ENDTRACK CAMS AND RED MAST POSITION



IMPORTANT:

INSTALL SUPERIOR ENDTRACK CAM ON THE LAST MAST AND THEN RED MAST WITHOUT RACK. USE VERTICAL REGULATION TO ACHIEVE BETTER STOP POINT.

CHECK IF HOIST STOP IS PROPERLY PERFORMED:

- 1. RAISE ("MANUAL" MODE) UNTIL HOIST STOPS. CHECK THAT THE MACHINE STOPS WHEN F.C.S SWITCH TOUCH SUPEROR CAM, AND ALSO THAT RED MAST'S NOT REACHED.**
- 2. DESCEND ("MANUAL" MODE) UNTIL HOIST STOPS AND CHECK IF 2 M SWITCH HAS REACHED INFERIOR CAM. CHECK THAT LAST TRAVEL UNTIL Ref. Point ONLY CAN BE COMPLETED WITH "HOLD-TO-RUN" BUTTON OF CAGE CONTROL. CHECK IF THE MACHINE STOPS WHEN F.C.B SWITCH TOUCH INFERIOR CAM. (Ref. Point)**

THESE TESTS ARE VERY IMPORTANT BEFORE FURTHER ASSEMBLY!!

- Step 7. Installing cable holder.

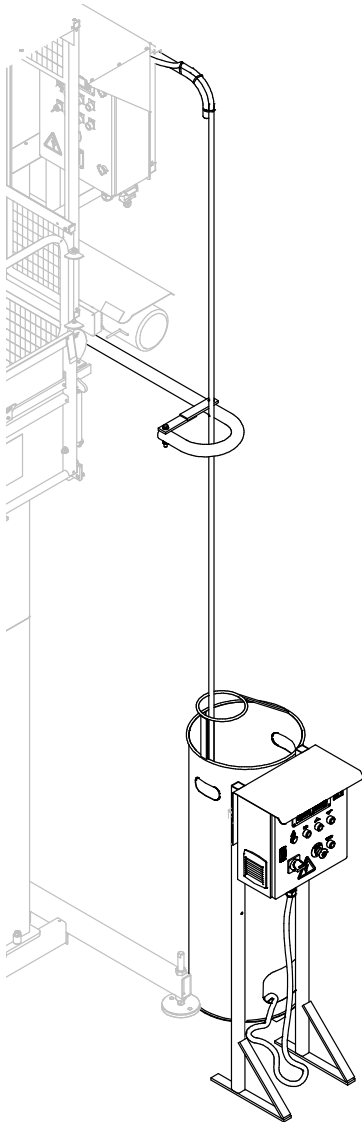

INSTALLING CABLE HOLDER

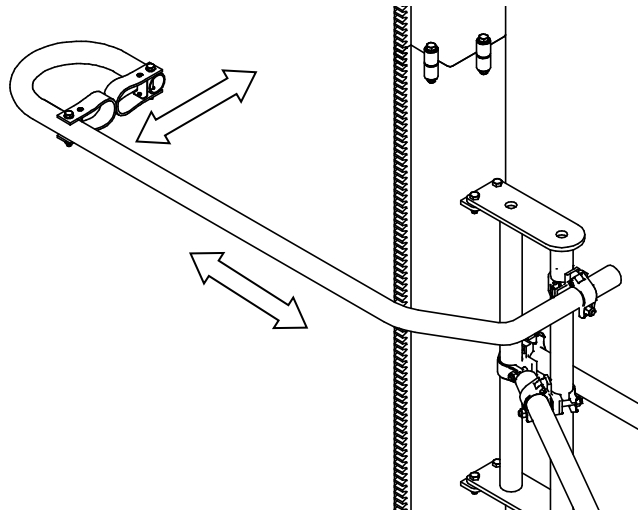

INSTALACION DE GUIAS DE CABLE

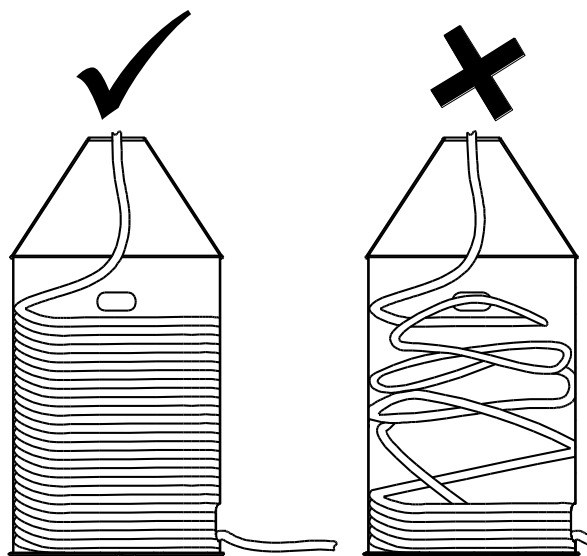

CABLE ROLLING IN CABLE HOLDER

• Step 8. Installing base enclosure.



ATTENTION:

INSTALLATION OF A BASE ENCLOSEE IS REQUIRED IN ACCORDANCE WITH HEREIN ESPECIFICATION OF EUROPEAN STANDARD EN 16719:2014

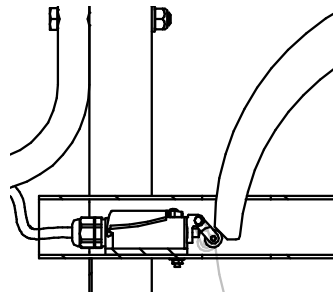
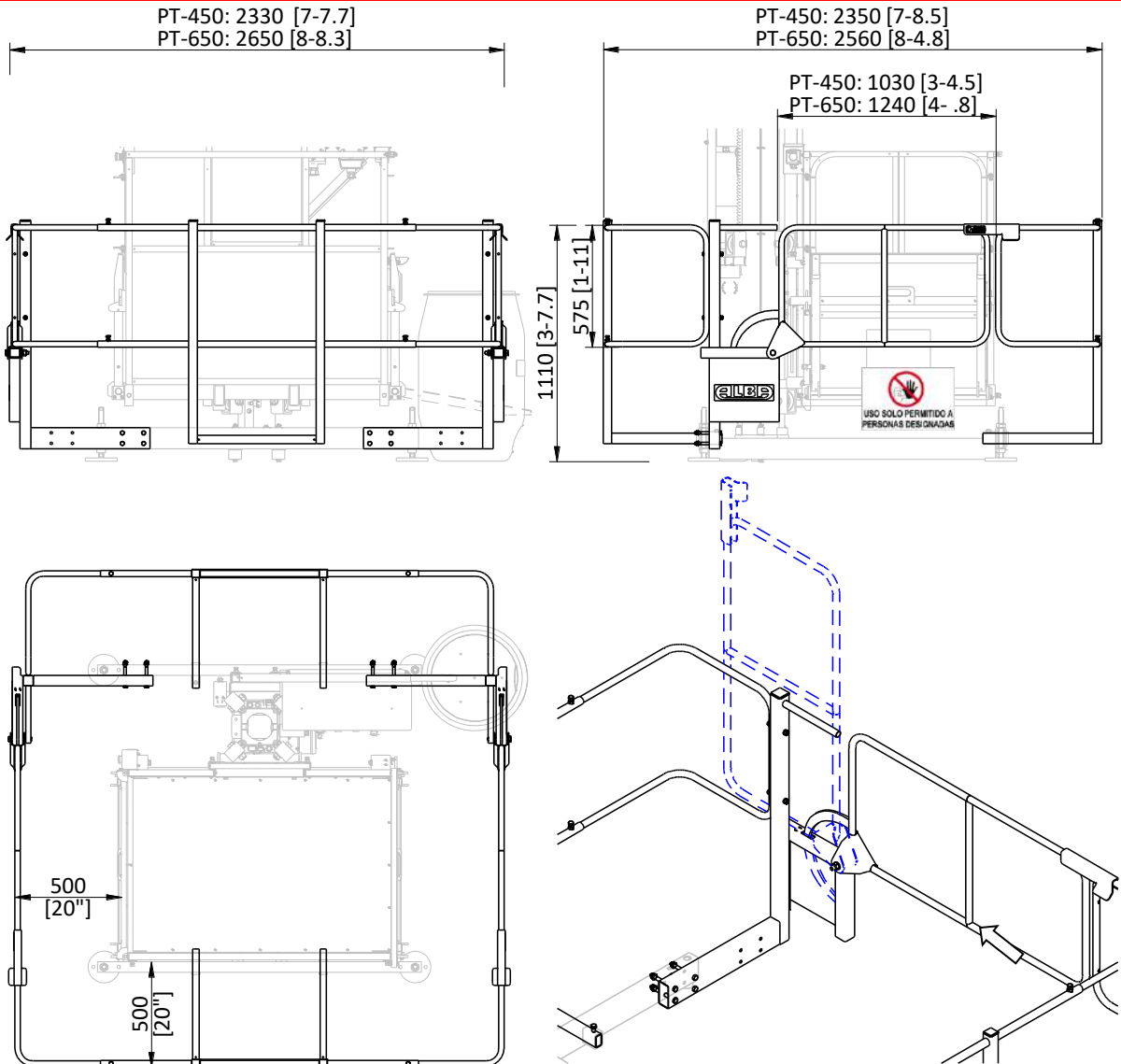

DOOR SWITCH FITTING

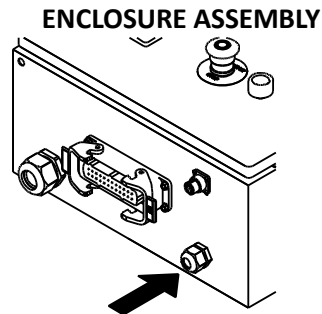

DOOR SWITCH CONNECION

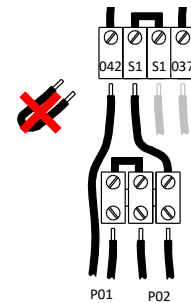

ATTENTION:

IN NORMAL USE, THE LIFT WILL STOP AT THE 2M CAM. FURTHER MOVEMENTS OF THE HOIST UNDER 2m. WILL BE WITH "RUN" BUTTON CONTINUOUSLY PRESSED.

• Step 9. Installing landing doors.

• **SWINGING DOOR LANDING DOORS (USUALLY TO SLAB):**

56 Kg

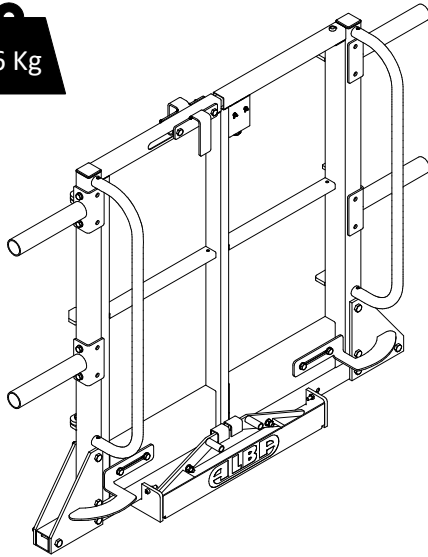

162.5 SWINGING LANDING DOOR 830

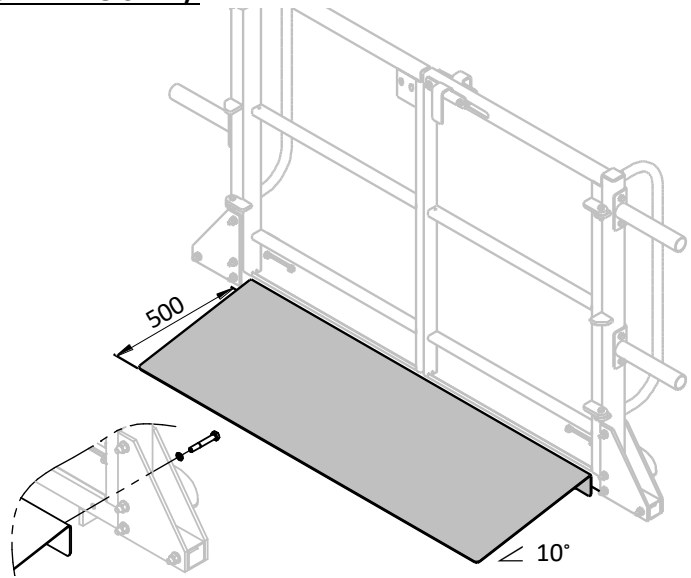

OPTION – 162.56 ACCESS RAMP

INSTALLATION IN CONCRETE SLAB OR STRUCTURE

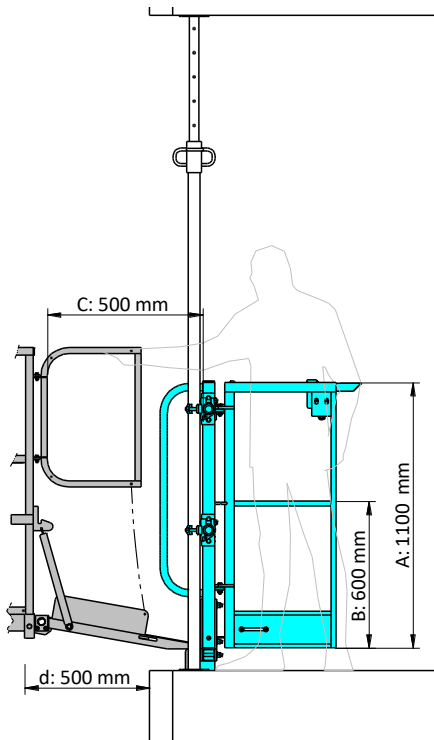

INSTALLATION DISTANCES

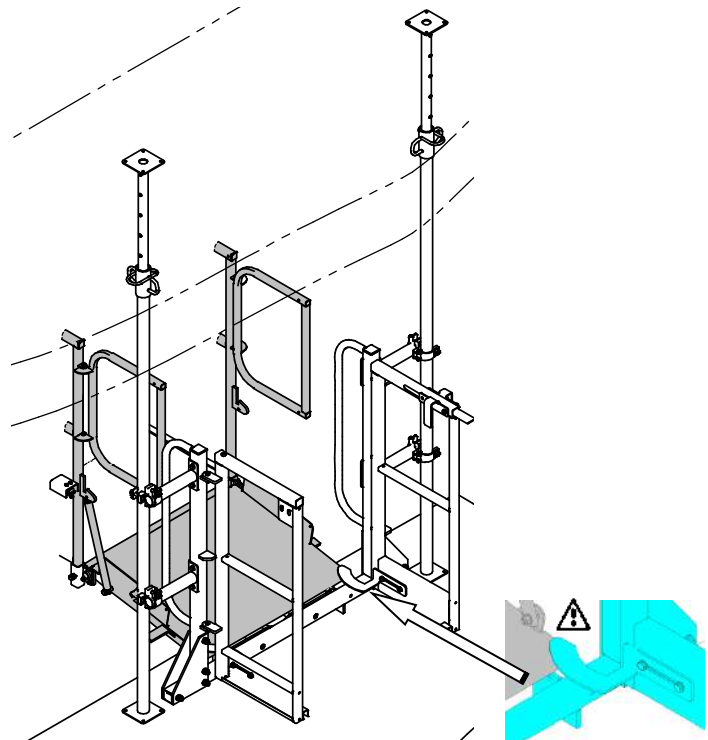

ASSEMBLY DETAIL

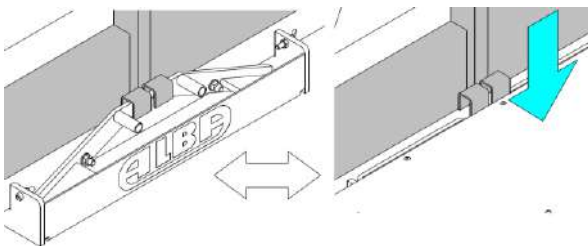

UNLOCKING – OPENING LANDING DOOR

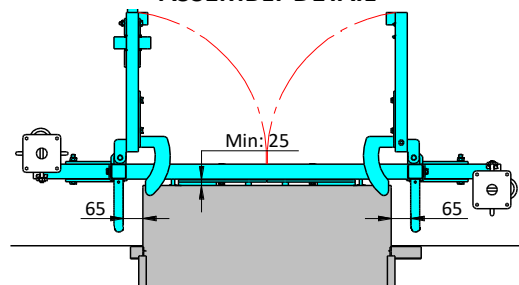

DOOR ASSEMBLY ADJUSTMENT

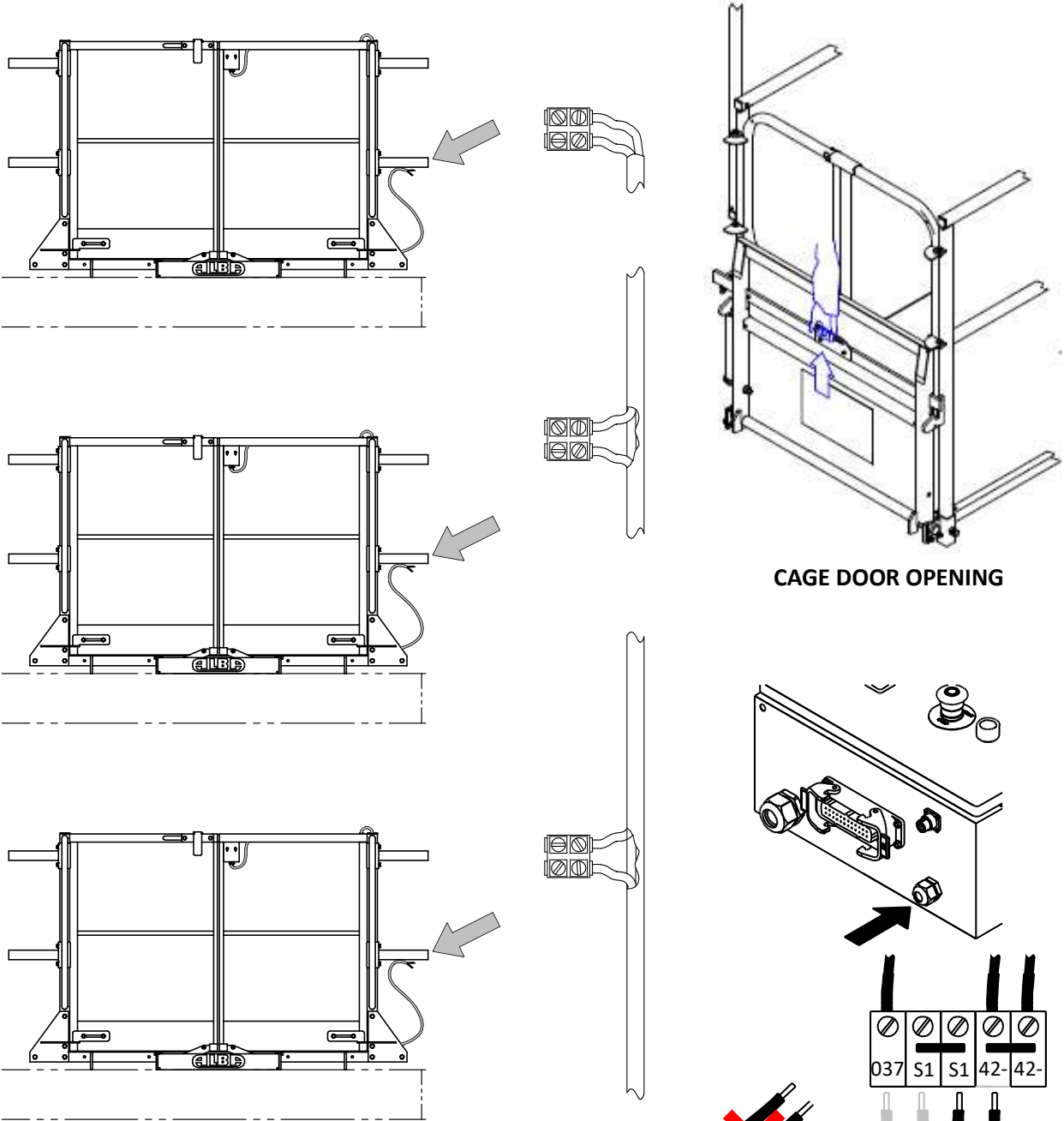

CAGE DOOR OPENING

CONNECTION OF LANDING DOOR ELECTRICAL SWITCHES (S1-037)

CONNECTION TO BASE PANEL

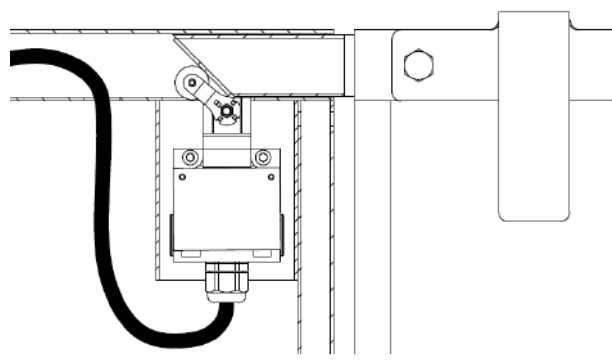

ADJUSTMENT OF LANDING DOOR SWITCH

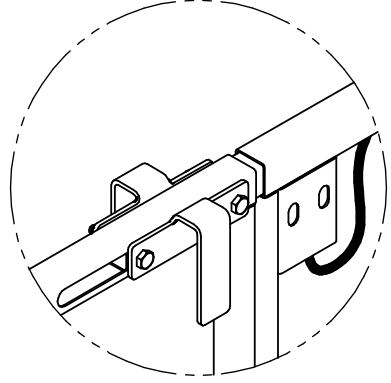

LANDING DOOR LATCHING

· SLIDING DOOR LANDING DOORS (USUALLY TO SCAFFOLD):



ATTENTION:

ADJUST DOOR POSITION SO THAT, WHEN CAGE RAMP IS DROPPED, LANDING DOOR INTERLOCK IS RELEASED AND DOOR CAN SLIDE TO OPEN.

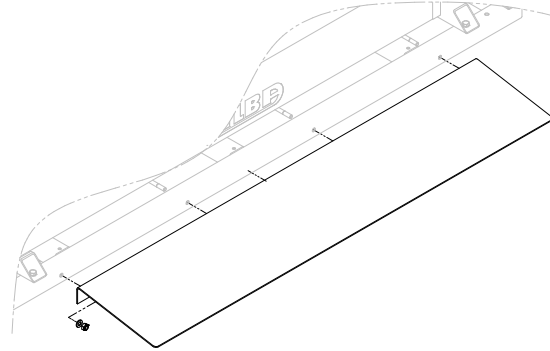
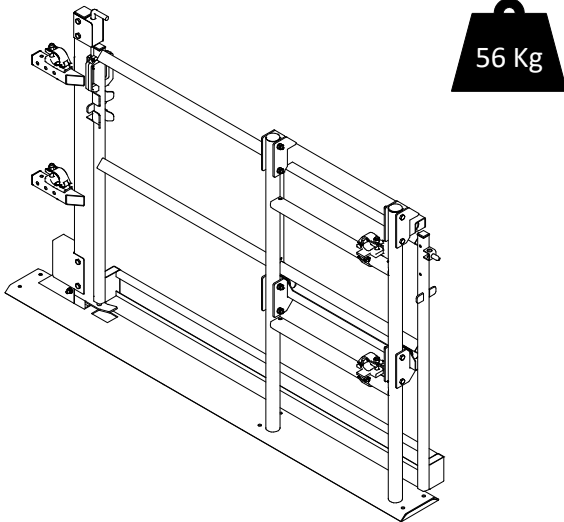

099.5 SLIDING LANDING DOOR 830

OPCIONAL – 099.56 ACCESS RAMP (∠ 10°)

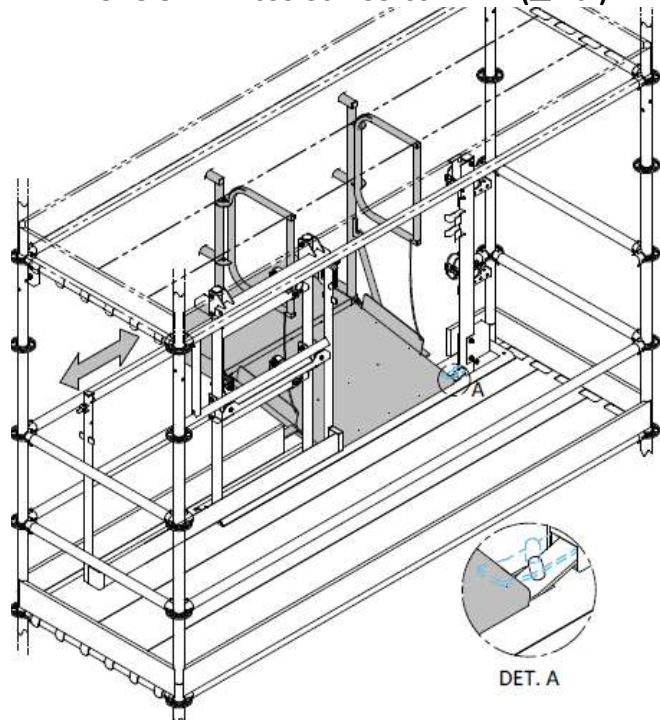
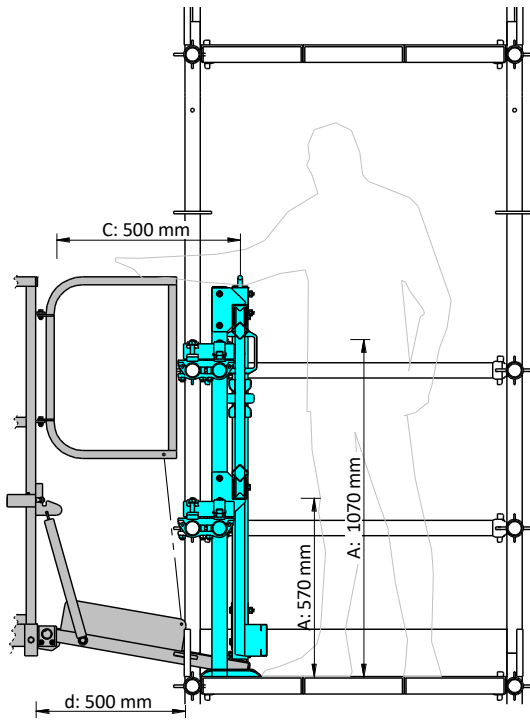

INSTALLATION IN TO SCAFFOLD STRUCTURE

INSTALLATION IN TO SCAFFOLD STRUCTURE

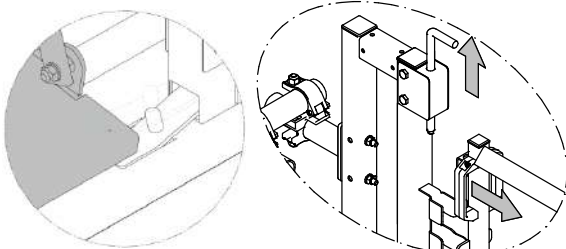

UNLOCKING – OPENING LANDING DOOR

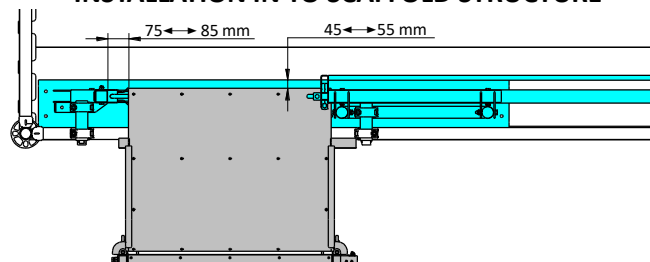

DOOR ASSEMBLY ADJUSTMENT

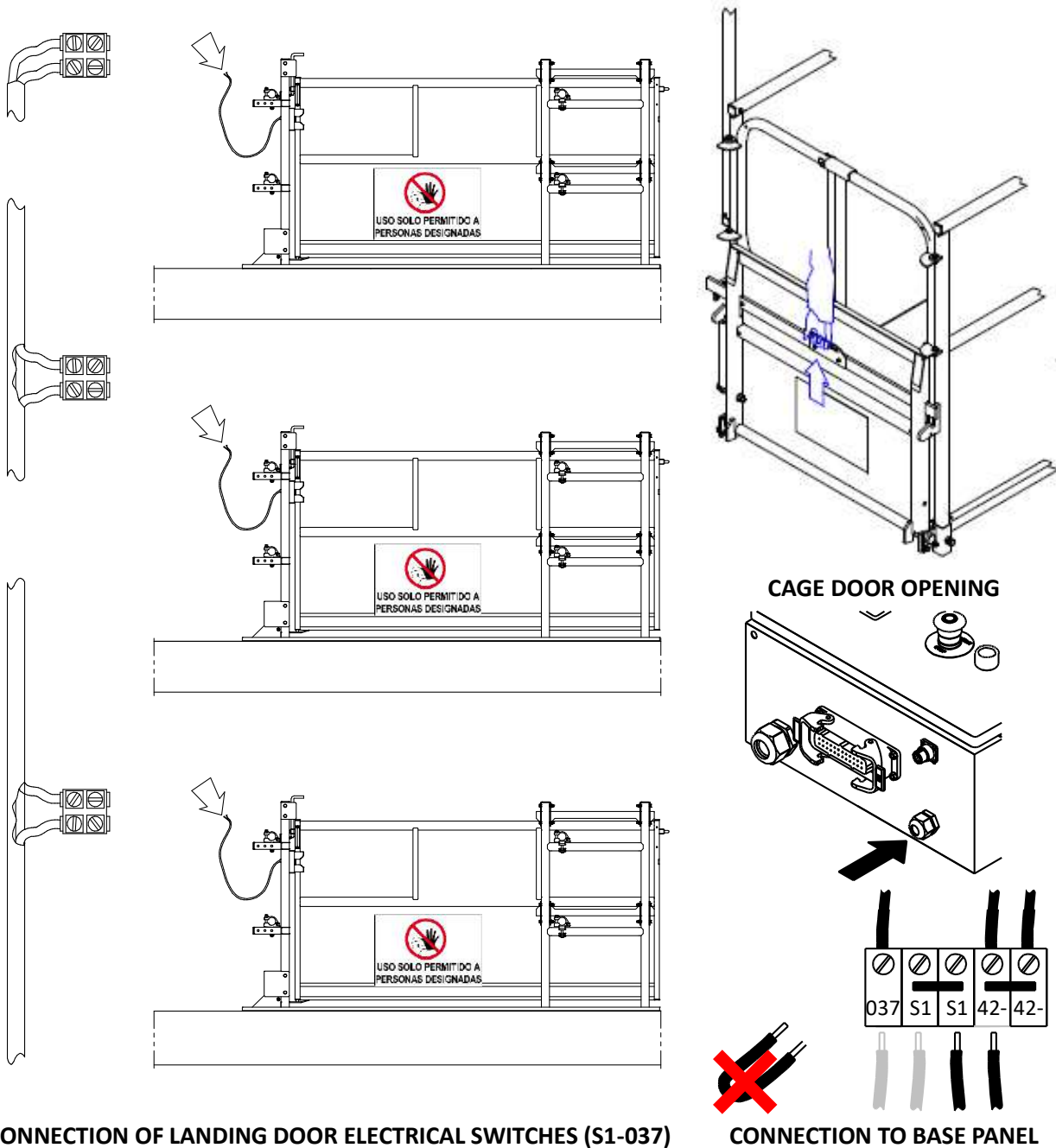

IMPORTANT:

ONCE THE DOOR MICROSWITCHES ARE INTER-CONNECTED, AND CONNECTED TO BASE CONTROL PANEL, IT'S NECESSARY THAT ALL DOOR ARE CLOSED TO MOVE THE PLATFORM.

MAKE SURE THAT THE CAGE DOORS ARE PROPERLY CLOSED AND LOCKED BEFORE MOVING THE HOIST.

• Step 10. Parachute testing.



IMPORTANT:
AT THE END OF THE ASSEMBLY OF THE MACHINE, PRIOR TO USE, IT WILL BE MADE A TEST ON THE PARACHUTE

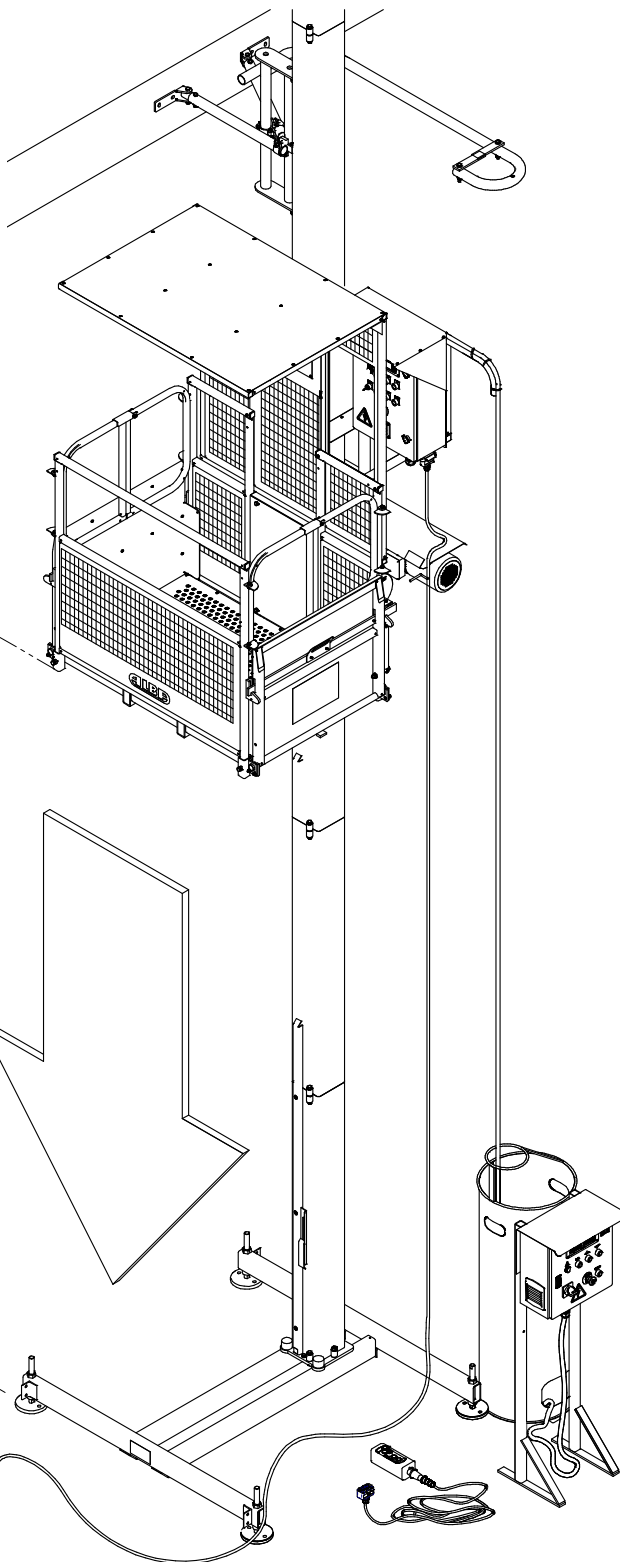
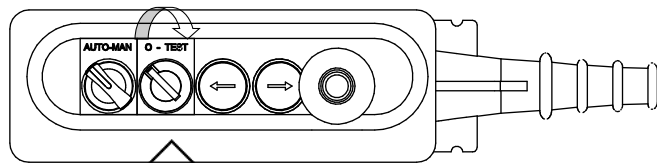

WARNING:
DANGEROUS OPERATION!



PARACHUTE TEST PROCEDURE (Cap. 4)

• Step 11. Installing landing level cams.



ATTENTION:

BEFORE USING THE PLATFORM, IT IS NECESSARY TO INSTALL THE LANDING CAMS IN THE MAST AT DESIRED LANDING LEVELS.

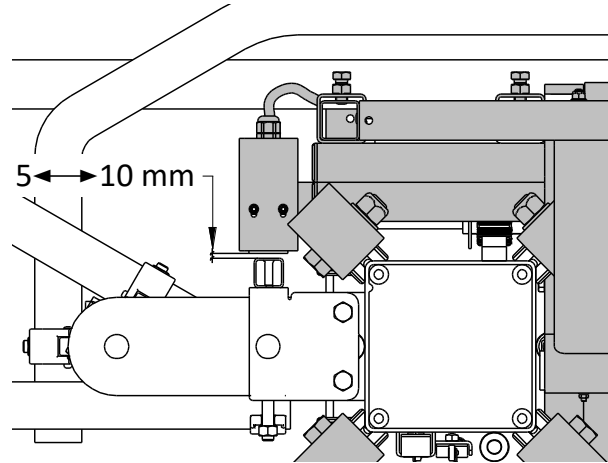
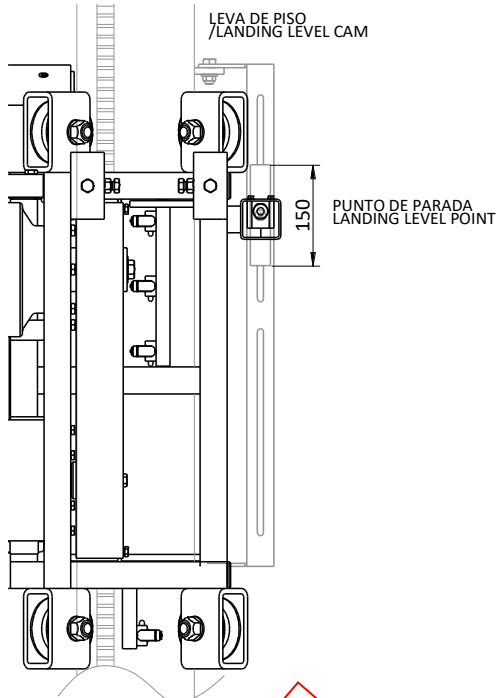

ADJUSTING CAM POSITION

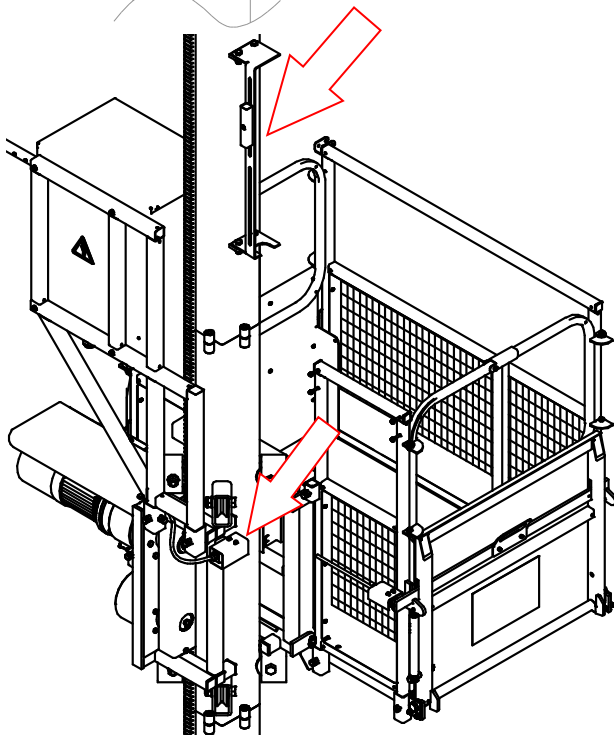

INSTALLING LANDING LEVELS CAM IN THE MAST

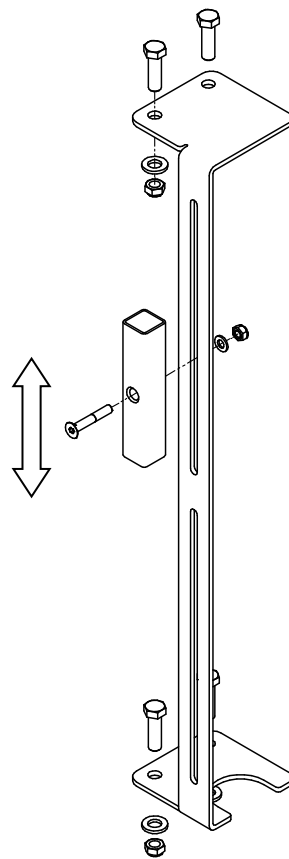

LEVA DE PARADA Ref: 099.55



IMPORTANT:

ONCE THE FLOOR CAMS ARE INSTALLED, MAX. NUMBER OF FLOOR IS TO BE PROGRAMMED IN THE CPU SYSTEM, SO THAT WAY, OPERATOR OF THE PLATFORM ONLY CAN SELECT ONE OF THE LANDING LEVELS PROGRAMMED.

- Step 12. Programming landing levels.



**PROGRAMMING OPERATIONS ARE CARRIED OUT FROM THE CABIN SWITCHBOARD.
IN EVERY NEW ASSEMBLY, OR IF THE ER E2 MESSAGE APPEARS, YOU MUST PROCEED REBOOT THE MEMORY OF THE CPU.**

DELETE MEMORY / INITIALIZATION

- Step 1. Select MANUAL mode.
- Step 2. Place the elevator in the Reference Point (INFERIOR ENDTRACK LIMIT) (FCB).
- Step 3. Process:

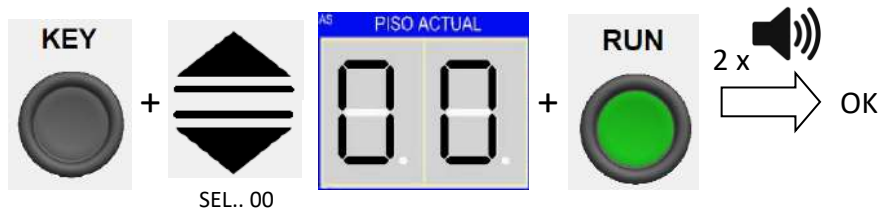

- Step 4. Release KEY: 1 x INITIALIZATION. OK

MAXIMUM FLOOR PROGRAMMING



**ATTENTION:
THE CONTROL ALLOWS TO MEMORIZE THE NUMBER OF FLOORS THAT HAVE BEEN INSTALLED, TO PREVENT THAT A FLOOR BE SELECTED IN OPERATION ABOVE THE LAST INSTALLED CAM.**

- Step 1. Select MANUAL mode.
- Step 2. Press up from the cabin control until you leave the Reference point FCB (a few cm.)
- Step 3. Process:

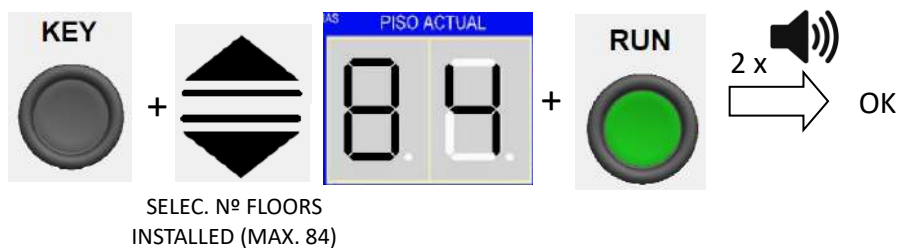

- Step 4. Release KEY. 1 x MEMO Nº MAX. FLOORS OK



**IMPORTANT:
AFTER SAVING MAXIMUM NUMBER OF FLOORS, THE HOIST MUST BE DOWN TO FCB IN "MANUAL" MODE. AFTER CHANGING TO "AUTO" MODE YOU WILL BE ABLE TO START WORKING.**

NEGATIVE FLOORS

IMPORTANT:
 THE HOIST ALLOWS TO DISPLAY NEGATIVE FLOORS. DEFINING NEGATIVE FLOORS
 DISPLACES. REF. POINT TO THE LOWEST POINT OF THE ROUTE. NEGATIVE FLOORS
 ONLY AFFECT THE DATA SHOWN ON THE DISPLAY.

- Step 1. Select MANUAL mode.
- Step 2. Place the hoist in reference point FCB
- Step 3. Process:

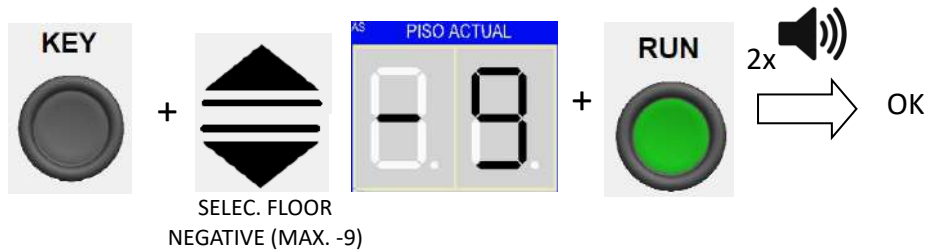

- Step 4. Release KEY 1 x \Rightarrow MEMO NEW REFERENCE POINT IN NEGATIVE FLOOR



IMPORTANT:
 WHEN DEFINING NEGATIVE FLOORS, REFERENCE POINT IS DEFINED ON THE LOWER
 FLOOR. WHEN PROGRAMMING MAX. NUMBER OF FLOORS MUST BE TAKEN INTO
 ACCOUNT OF NEGATIVE FLOORS.
 Example: PTO. REF.: -5, P.MAX: 15" THE DISPLAY SHOWS ONLY: -5 \div 10

- Step 13. Installing landing levels call system – OPTION.



ATTENTION:
 CALLING THE HOIST FROM THE FLOORS WILL ONLY BE POSSIBLE WHEN THE HOIST
 IS FREE (GREEN PILOT OFF).

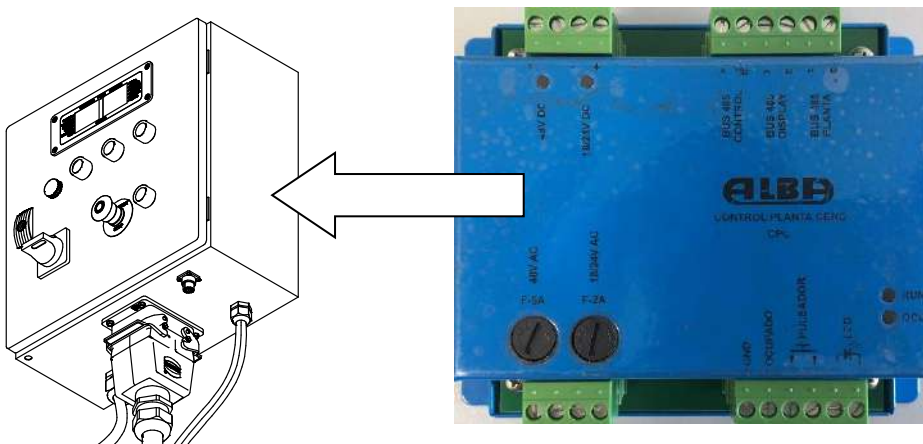

E-CPC-A CARD FOR FLOOR CALLS MANAGEMENT ON INFERIOR CONTROL BOARD

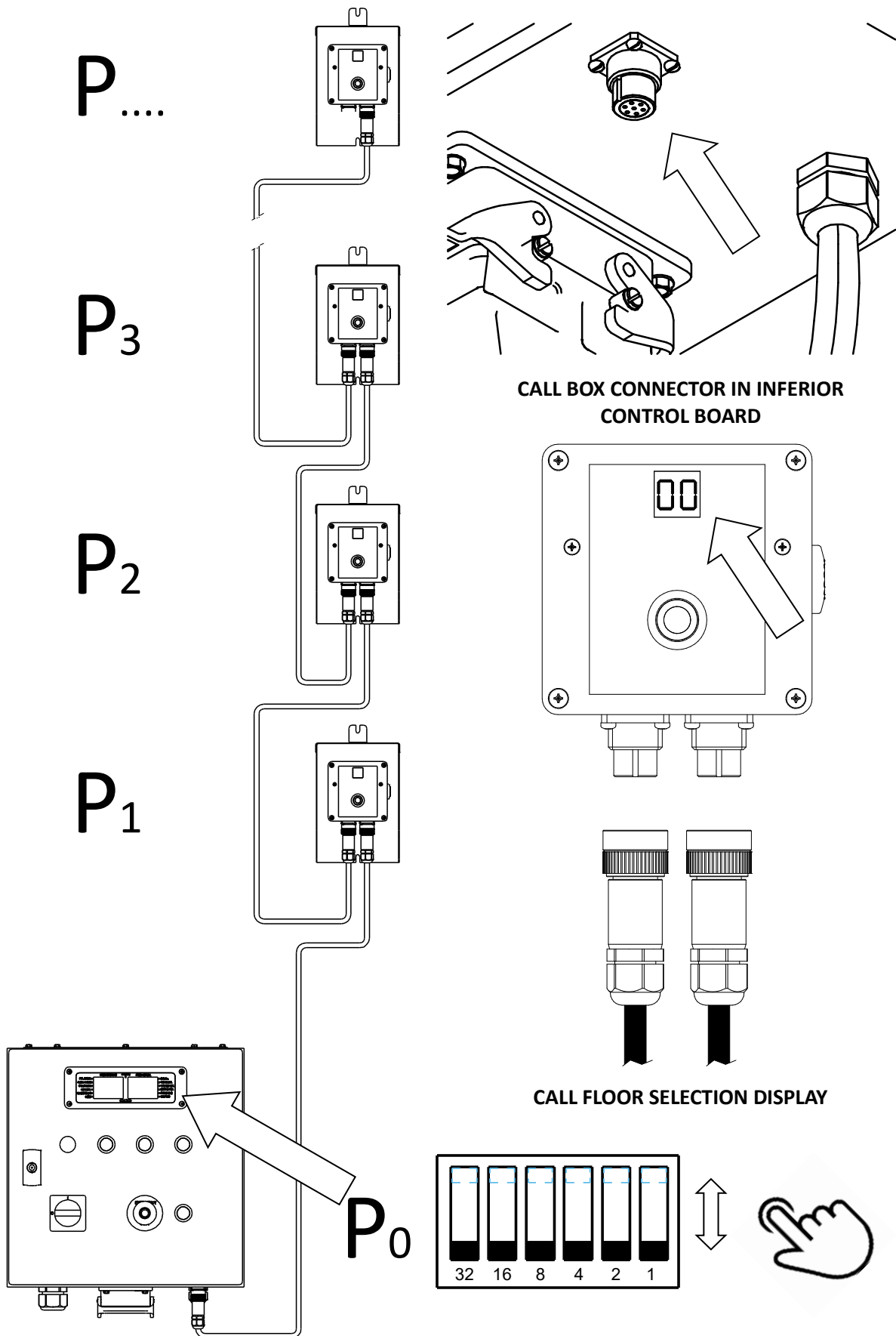

INSTALLATION OF FLOOR CALL BOXES

SELECTING THE CALL FLOOR (BINARY CODE)

• Step 13. Assembly of roof and mast protector.



IMPORTANT NOTE:

IN ACCORDANCE WITH THE STANDARD EN 16719:2014, THE PLATFORM SHOULD BE EQUIPPED WITH A FALLING OBJECTS PROTECTIVE GUARD. THE GUARD MAY BE REMOVABLE FOR INSTALLATION AND MAINTENANCE TASK, BUT ONLY IF A SITE-SPECIFIC RISK ASSESSMENT INDICATES THAT THERE IS MINIMAL RISK OF OBJETS FALLING ON THE PLATFORM, THE FALLING OBJECTS GUARD MAY BE REMOVED. ALBA SUPPLIES THE GUARD WITH THE MACHINE, SO IT IS THE RESPONSIBILITY OF THE INSTALLER A RISK ANALYSIS AND THE USE OF THE TRANSPORT PLATFORM WITHOUT PROTECTION GUARD.

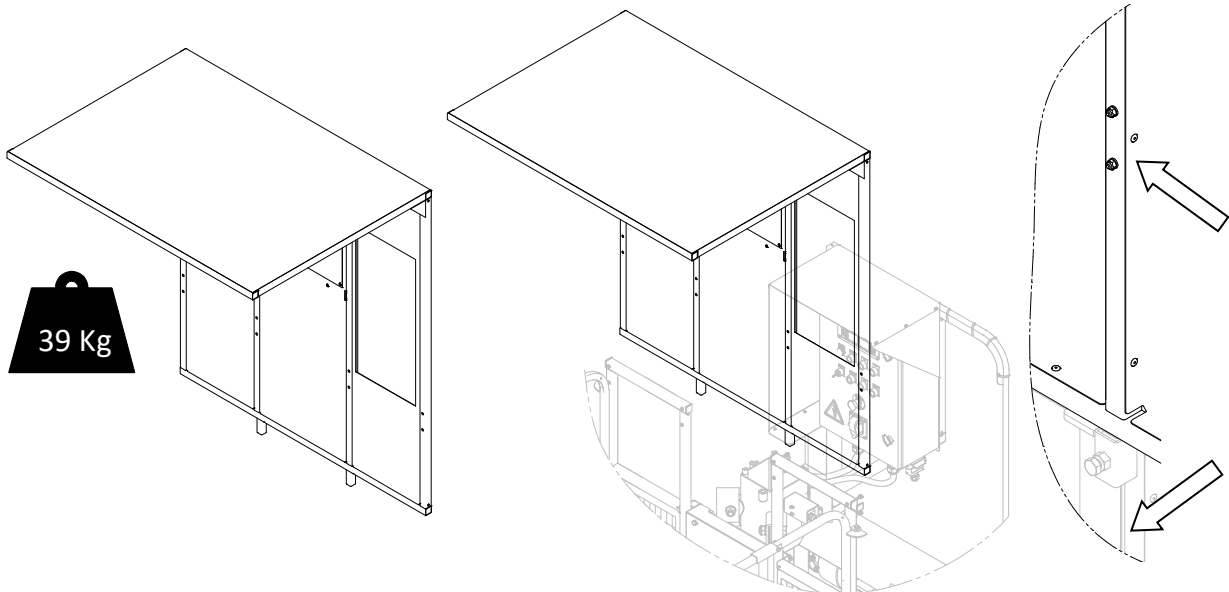

MAST AND ROOF PROTECTOR PT-450

ASSEMBLY OF MAST PROTECTOR (I)

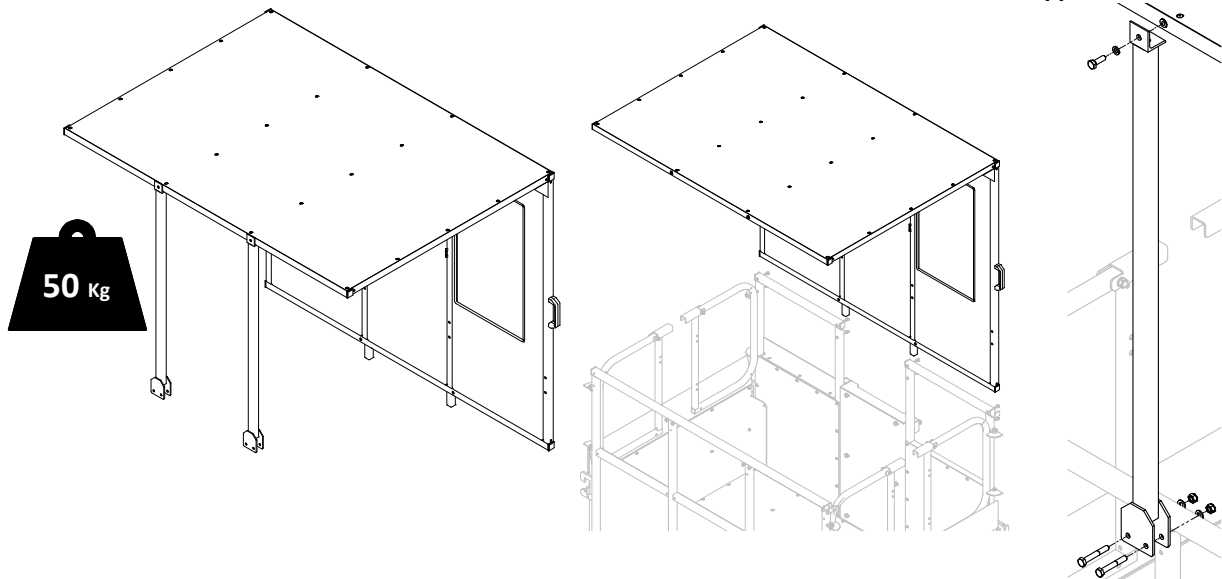

MAST AND ROOF PROTECTOR PT-650

ASSEMBLY OF MAST PROTECTOR (II)

2.4. Dismantling the hoist

For the dismantling of elevator perform the reverse process to that described in this manual, with particular attention to the tasks that present a risk of falling.



**ATTENTION:
FOR MACHINE DISMANTLING "MANUAL" MODE IS TO BE USED, WITHOUT LOADS,
AND OPERATING THE HOIST FROM CAGE CONTROL.**

Step 1. Dismantling mast column and anchorages

Remove first the red Mast and upper stop cam and then the column of masts and anchors. For that, you can remove the platform falling objects protector ceiling and folding the mast protector.



**ATTENTION:
REMOVE MAST AND SCREWS ALWAYS AT THE SAME TIME!
NEVER RAISE THE HOIST OVER A NON-SCREWED MAST MODULE!
THEN THERE IS HIGH CHANCE OF COLLAPSE AND SERIOUS INJURY!**



Step 2. Dismantling cable system and guides

Remove the cable bracket and remove the cable guides, continuing with the dismantling of the mast column to the lower limit.

Step 3. Electrical devices disconnecting

Once you reach the lower limit, disconnect the power supply and remove electrical equipment.

Step 4. Dismantling the cage

Remove the cage by releasing union bolts, by the same procedures described for mounting.

Step 5. Dismantling base frame

Release buffers, remove anchorage to ground. The hoist is ready for transport.



**ATTENTION:
IMPORTANT NOTE ON COMPLIANCE WITH EUROPEAN DIRECTIVE 2006/42/CE.**

CE DECLARATION OF CONFORMITY is valid only for machines purchased and installed with all original components supplied by CANOPY BRANDS EUROPE, S.L.U. and following all the instructions provided in this user's manual, ensuring compliance with all SSER Annex I of Directive 2006/42/EC.

Otherwise, the machine can't be put into service until final assembly is declared in accordance with the specifications of Annex II of the Directive.

3. USING THE MACHINE.

3.1. Introduction.



WARNING:

HOIST CAN ONLY BE USED BY THE DESIGNATED PERSONS, WHO HAVE BEEN INSTRUCTED IN THE SAFELY HOIST OPERATION

ACCESS TO THE PLATFORM FOR LOAD AND UNLOAD ONLY IS ALLOWED FOR TRAINED PERSONS

FIT THE LOAD CONVENIENTLY INSIDE THE CAGE, ESPECIALLY IF IS TRANSPORTED WITH PEOPLE TRAVELING TOGETHER.



IMPORTANT:

TWO OPERATION MODE ARE POSSIBLE WITH THE HOIST:



- "MANUAL" MODE (ONLY FOR ASSEMBLY): HOIST MOVEMENTS ARE PERFORMED WITH HOLD-TO-RUN BUTTONS. CONTROL IS ALLOWED ONLY FROM THE CAGE CONTROL (▲ ▼).
- KEEP THE KEY FOR "MANUAL" MODE SWITCH OUT OF THE REACH OF ELEVATOR USERS.



- "AUTO" MODE: THE MACHINE IS USED BOTH FROM THE CONTROL ON THE FLOOR (ONLY LOADS), AND FROM THE CAGE CONTROL (PERSONS AND LOADS). THE MACHINE IS MOVING ON PROGRAMED LANDING LEVELS. (SEE LANDING LEVELS PROGRAMMING)



- HOIST ALLOWS (AS AN OPTION) A LANDING LEVELS CALLING CONTROL SYSTEM).



ATTENTION:

DUE TO SAFETY PURPOSES, WHEN DESCENDING, HOIST STOPS WHEN IT REACH 2M REMAINING TRACK UNTILL INFERIOR ENDTRACK LIMIT IS ONLY TO BE POSSIBLE BY HOLDING "RUN" BUTTON.

PT-2V: IN "PERSONS" MODE, THE CONTROL HAS A DELAY OF 3 SEC. TO COMPLETE DOWNWARDS MOVEMENT OF 2M ZONE.



WARNING:

"MANUAL" MODE ONLY IS ALLOWED FOR AUTHORIZED AND COMPETENT TECHNICAL PERSONS, WHO WILL KEEP THE KEY TO PREVENT USE BY UNAUTHORIZED PERSONNEL.

3.2. Using “MANUAL” mode.



WARNING:
“MANUAL” MODE IS USED FOR HOIST ASSEMBLY / DISMANTLING TASKS, AND FOR INSPECTION AND MAINTENANCE.
HOIST HANDLING IS PERFORMED ONLY FROM THE CAGE CONTROL.
OPERATE THE PLATFORM IN “MANUAL” MODE IS FORBIDDEN BY UNAUTHORIZED USERS.

MAKE SURE THE CAGE DOORS ARE PROPERLY CLOSED AND LOCKED BEFORE MAKING ANY MOVEMENT WITH THE PLATFORM.

A) Transport platform PT 450/650-2V:

DESCRIPTION OF THE CONTROLS - MANUAL MODE

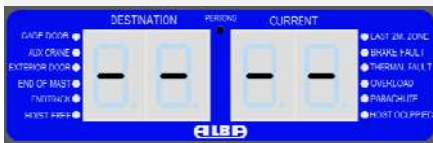

MANUAL MODE ACTIVE



LIGHT - OUT OF SERVICE

START EQUIPMENT RESET BUTTON

AUTO-MAN



MANUAL MODE SELECTOR



SELECTOR NOT ENABLED



UP - DOWNLOAD MANUAL

KEY

PROGRAMMING BUTTON

RUN

LOWERING MANUAL - ZONE 2 m.

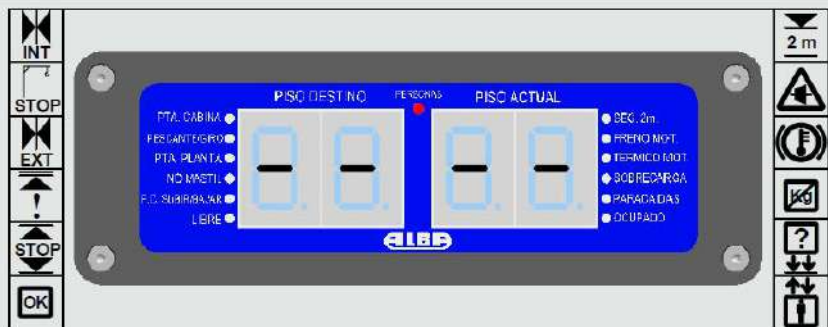

RUN



AUTO-MAN

START

KEY



ATTENTION:

ALL MOVEMENTS IN CASE OF USE OF THE MANUAL MODE WILL BE WITH THE CONTROL UP - DOWN PUSHING CONTINUOUSLY AND WITH SLOW SPEED.

B) Transport platform PT 450/650-1V:

DESCRIPTION OF THE CONTROLS - MANUAL MODE

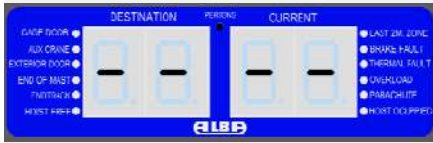

MANUAL MODE ACTIVE



LIGHT - OUT OF SERVICE

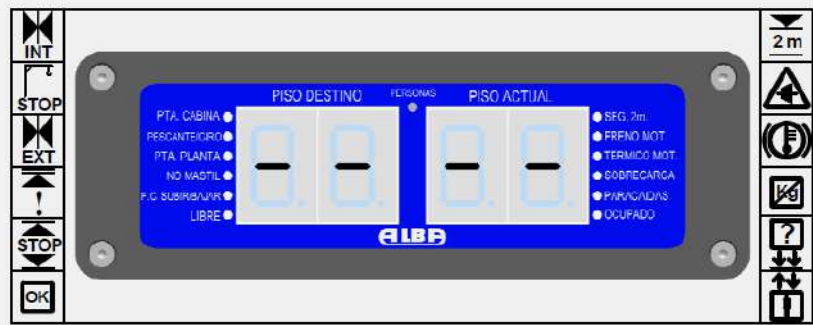

START

EQUIPMENT RESET BUTTON

AUTO-MAN



MANUAL MODE SELECTOR



NOT ENABLED

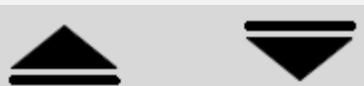

UP - DOWNLOAD MANUAL

KEY

PROGRAMMING BUTTON

RUN

LOWERING MANUAL - ZONE 2 m.



AUTO-MAN



START



KEY



RUN



ATTENTION:



ALL THE MOVEMENTS IN CASE OF USING THE MANUAL UP - DOWN PUSHING CONTINUOUSLY AND WITH NOMINAL SPEED.



WARNING:

IN ALL MODELS, IF THE HOIST IS IN "MANUAL" MODE, THE CONTROL FROM THE BOTTOM PANEL IS DISABLED, PREVENTING THE HANDLING OF THE HOIST BY USERS.

3.3. Using "AUTO" mode.



IMPORTANT:
 "AUTO" MODE IS USED FOR NORMAL HANDLING OF THE HOIST BETWEEN PROGRAMMED LEVELS, WITH BOTH CAGE CONTROL ("PERSONS") AND GROUND CONTROL ("LOADS")

· AUTO MODE – "PERSONS" SELECTOR:

A) Transport platform PT 450/650-2V:

DESCRIPTION OF CONTROL – AUTO MODE- "PERSONS" (MAIN CONTROL BOARD)

AUTO MODE WITH HOIST IN THE POINT OF REFERENCE

AUTO MODE WITH HOIST OUT OF THE POINT OF REFER.

LIGHT - OUT OF SERVICE

AUTO-MAN

SELECTOR AUTOMATIC MODE

"PERSONS" MODE

DESTINATION FLOOR SELECTION

RUN

SHIPPING TO DESTINATION FLOOR

ATTENTION:

THE MOVEMENT UP TO THE FLOOR DESTINATION OF THE HOIST IN AUTO- PEOPLE MODE WILL BE WITH THE CONTROL "RUN" PULSED IN A CONTINUOUS MANNER AND SLOW SPEED.

B) Transport platform PT 450/650-1V:

DESCRIPTION OF CONTROL – AUTO MODE - “PERSONS” (MAIN CONTROL BOARD)

 AUTO MODE WITH HOIST
IN THE POINT OF REFERENCE

 AUTO MODE WITH HOIST OUT OF
THE POINT OF REFERENCE

LIGHT - OUT OF SERVICE



AUTO-MAN



SELECTOR AUTOMATIC MODE

AUTO-MAN



START



KEY



RUN

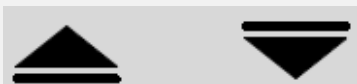

KEY

 PERSONS MODE ACTIVATION
(ACTIVE DURING 15 SG.)

DESTINATION FLOOR SELECTION

RUN

SHIP TO DESTINATION FLOOR

ATTENTION:

THE MOTION TO THE FLOOR DESTINATION OF THE HOIST IN AUTO MODE – “PERSONS” MODE WILL BE AUTOMATIC AFTER PULSING “RUN”, AND AT NOMINAL SPEED.

ATTENTION:

IF “AUTO” MODE IS SELECTED WITH THE HOIST OUT OF REFERENCE POINT, ONLY “TOTAL DESCEND” TO REFERENCE POINT IS ALLOWED. ONCE THE HOIST UN ON REFERENCE POINT, IT CAN BE COMMISIONED AGAIN.

ATTENTION:

IF OPERATOR TURNS CONTROL FROM AUTO – “PERSONS” TO AUTO – “ONLY LOADS” HOIST WILL REMAIN “OCCUPIED” FOR 15 S. AFTER THAT TIME, LOWER INFERIOR CONTROL PANEL FOR USE AS “ONLY LOADS” HOIST IS ENABLED.

· AUTO MODE – “ONLY LOADS” SELECTOR (ALL MODELS):

DESCRIPTION OF CONTROLS – AUTO MODE- “ONLY LOADS” (GROUND PANEL)



AUTO MODE WITH HOIST
IN THE POINT OF REFERENCE



AUTO MODE WITH HOIST OUT OF
THE POINT OF REFERENCE.

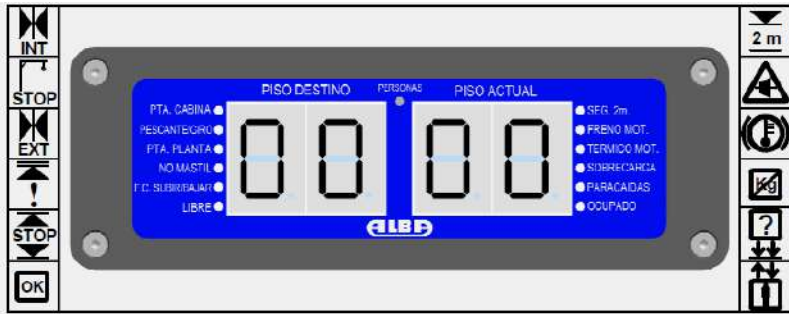

LIGHT - OUT OF SERVICE



MODE “SOLO CARGAS”
(ON CAGE)



SELECTION OF DESTINATION
FLOOR BUTTONS

RUN

SHIP TO DESTINATION FLOOR



START

ATENCIÓN:



THE MOTION TO THE FLOOR DESTINATION OF
THE HOIST IN AUTO MODE – “ONLY LOADS”
WILL BE AUTOMATIC AFTER PULSING “RUN”,
AND AT NOMINAL SPEED.



ATTENTION: MODEL PT 450/650-2V

WHEN “AUTO” MODE IS SELECTED, PERSONS USE (CAGE) OR LOADS USE (GROUND)
HAVE TO BE CHOSEN.

ANY EXCHANGE PERSONS - LOADS SELECTOR WHEN THE PLATFORM IS IN
MOVEMENT, IS EFFECTIVE ONLY AFTER FINISHING THE CURRENT MOVEMENT.



ATTENTION: (ONLY MODEL PT 450/650-1V)

TO ENABLE CAGE CONTROL “KEY” BUTTON’S TO BE PRESSED. HOIST CONTROL
FROM CAGE (PERSONS) IS ALLOWED FOR 15 SEC, ANNULING GROUND PANEL.

AFTER 15 SEC. WITHOUT ORDER FROM CAGE CONTROL, CONTROL RETURNS TO
GROUND PANEL.

3.4. Security messages on the display.



IMPORTANT:

DURING THE OPERATION OF THE HOIST, TWO TYPES OF SAFETY MESSAGES CAN BE RECEIVED IN THE DISPLAY:

- MESSAGES "SECU": THE HOIST REMAINS OPERATIONAL IF IT WILL BE SAID FROM THE CAUSE OF THE SAFETY MESSAGE.
- MESSAGES "STOP": REQUIRES THE ACTION OF AN AUTHORIZED TECHNICIAN TO RESOLVE THE PROBLEM AND REACT THE CONTROL.

"SECU" MESSAGES (ACTION OF AN HOIST USER)

	LED	PROCEDURE
	OVERLOAD	
	AUXILIARY CRANE	MAN Resolve warning - Resume operation.
	CAGE DOORS	AUTO Resolve notice - Press RUN
	LANDING DOORS	

"STOP" MESSAGES (ACTION BY AN AUTHORIZED AND COMPETENT TECHNICIAN)

	LED	PROCEDURE
	PARACHUTE	MAN 1) Press UPWARDS until display shows REST AUTO 2) Press DOWNWARDS until Ref. point (FCB) → Press KEY Turn key to MAN
	NO MAST	MAN 1) Press DOWNWARDS until display shows REST AUTO 2) Press DOWNWARDS until Ref. point (FCB) → Press KEY Turn key to MAN
	ENDTRACK UP	MAN 1) Press DOWNWARDS until display shows REST AUTO 2) Press DOWNWARDS until Ref. point (FCB) → Press KEY Turn key to MAN
	TEMP MOTOR	MAN 1) Resume relay (RT1, RT2), display shows REST AUTO 2) Press DOWNWARDS until Ref. point (FCB) → Press KEY Turn key to MAN
	FAULT BRAKE	AUTO/MAN DESCEND to lower end track limit → Call Tech. service. SAT 1) Check rectifier and rearm E4 → display shows RESET 2) Press KEY.

NORMAL MESSAGES

ENDTRACK DOWN	Ref. point platform (FCB)
2 m. ZONE	2 m. safety zone platform
HOIST FREE	Platform stopped and prepared
HOIST BUSY	Platform moving or busy
PERSONS	Control inside cage activated

(FCB): Inferior End track. Reference point for hoist movements.



IMPORTANT:

IN CASE OF SHOWING "STOP" MESSAGE, YOU MUST GO TO "MANUAL" MODE, AND FOLLOW THE INDICATIONS OF THE TABLE, UNTIL THE DISPLAY MARK "RSET" (RESET), TURN OFF THE ELEVATOR TO THE REFERENCE POINT (FCB) AND PRESS THE RESET BUTTON (KEY).



IMPORTANT:

MAKE SURE THAT THE CAGE DOORS ARE PROPERLY CLOSED AND LOCKED BEFORE MOVING THE HOIST.

OTHER MESSAGES IN THE DISPLAY

MANUAL Mode selected



Total descent to FCB (Ref. point) and RESET



Total descent to FCB (Negative Ref. point)



Memory error (ERASE MEMORY)



Reset control (PRESS KEY in FCB)

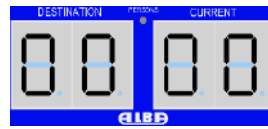

Hoist in AUTO mode and in FCB

3.5. Emergency lowering.

In case of power failure without the possibility of restoration, you can descent the cage handpicked, acting **WITH EXTREME CAUTION** on the release levers of the motor brakes on the cage roof. This must be done in small intervals to avoid machine acceleration.

CAUTION: DANGEROUS TASK

IF SAFETY GEAR SPEED IS EXCEEDED, PARACHUTE IS AUTOMATICALLY ENGAGED, BLOCKING ANY FURTHER CAGE MOVEMENT UNTIL TECHNICAL ASSISTANCE.

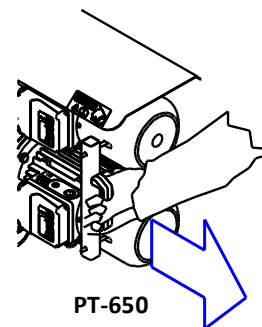
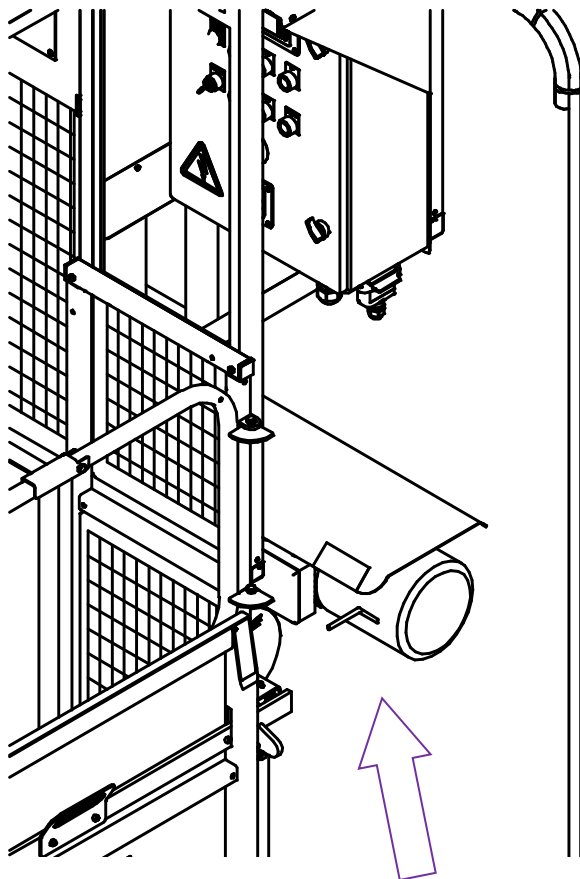
EMERGENCY LOWERING PROCEDURE

WARNING:

CASE OF PARACHUTE ACTIVATION HOIST SERVICE WILL BE SUSPENDED AND TECHNICAL SERVICE WILL BE NOTIFIED FOR INSPECTION AND HOIST RELEASING.

3.6. Checking hoist operation before commissioning.

**IMPORTANT:**

BEFORE HOIST COMMISSIONING, HOIST SERVICE RESPONSIBLE WILL CHECK IF HOIST IS IN COMPLIANCE WITH FOLLOWING POINTS:

- Hoist´s installed with all operational safety systems:
 - Landing floor are properly programmed
 - No destination can be chosen over last floor programed.
 - FCS microswitch stops hoist before reaching red mast.
 - Overload detector (inductive sensor) works properly
 - Brakes support the maximum load correctly.
 - FCB microswitch stops hoist on Ref. Point before reaching buffers.
 - The mast presence detector works correctly.
 - Display shows safety activations and operational LEDs correctly.
 - Landing levels hoist calling system works OK (if installed).
 - Hoist control inside cage works properly
- There´s no interference of hoist and external items, mast, anchors, supporting structure,..
- Landing doors are installed and there´s no interference with hoist mobile elements.
- Base fence is installed and there´s no interference with hoist mobile elements.
- Door releasing system for cage door / landing door / fence door are operative.

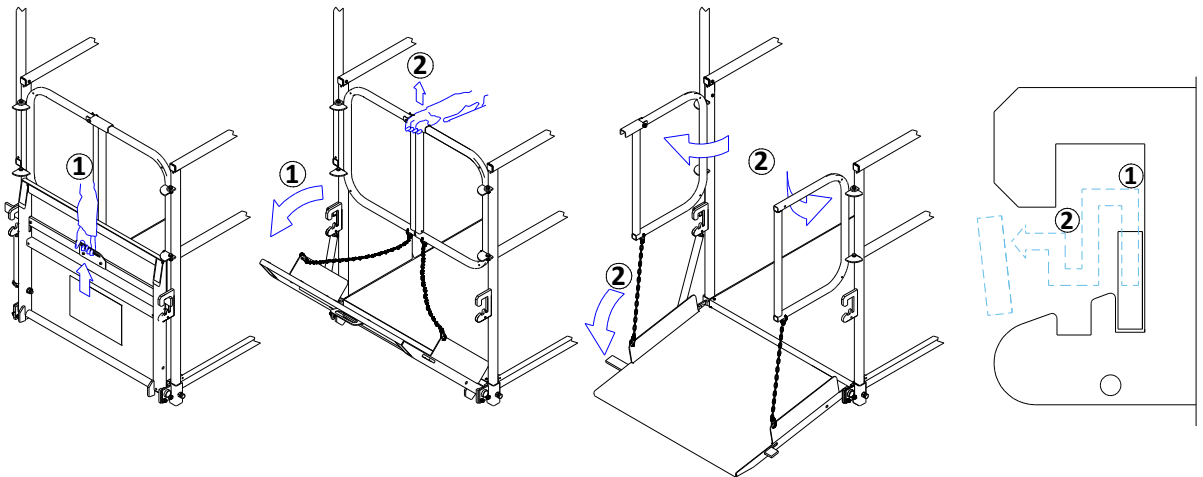

- Control microswitch for cage door / landing door / fence door work correctly
- The points of access to the platform and hoistway have adequate lighting.

**IMPORTANT:**

KEEP ORDER AND CLEANING IN THE ELEVATOR AND SURROUNDINGS

3.7. Notes on the use of -1C platforms (equipped with BATT)

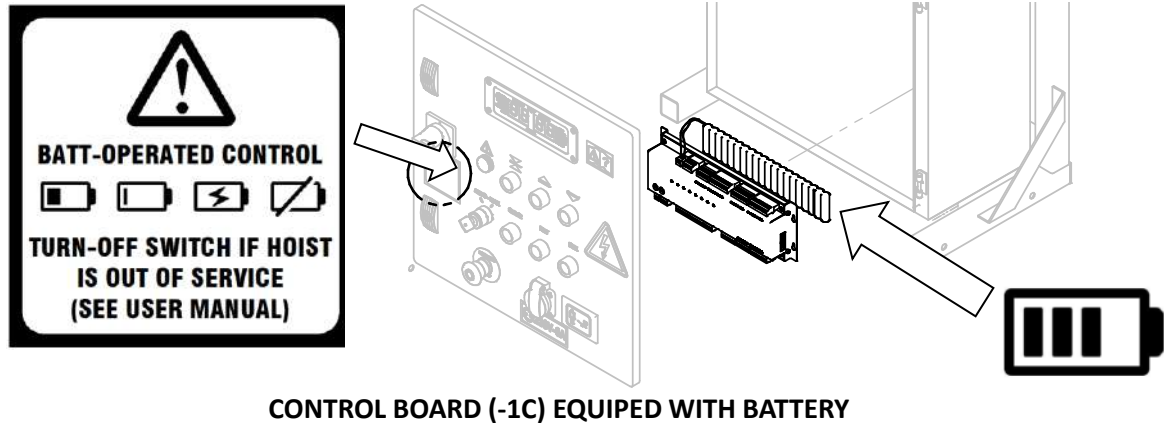

CONTROL BOARD (-1C) EQUIPED WITH BATTERY



ATTENTION:

PLATFORM MODEL -1C EQUIPED WITH ONLY POWER CABLE HAS A BATTERY TO AVOID LOSS OF POWER SUPPLY TO THE CPU WHEN THE PLATFORM IS STOPPED ON A LANDING LEVEL IN SERVICE.

CLOSE THE DOORS AND RESTART THE CONTROL, TO AVOID DISCHARGING THE BATTERY, OR SWITCH OFF THE CONTROL IF IT IS TO REMAIN STATIONARY FOR A LONG TIME.

3.8. Applications and uses forbidden.

- DON'T use the hoist on explosive atmospheres.
- DON'T use the hoist with higher load than shown in the plate.
- Load CAN'T be piled up at the cage floor bounds, **it must be located as near mast as possible**.
- DON'T transport loads out of cage floor.
- DON'T use the hoist in adverse weather conditions, rain, ice, snow, (See Ap. 1.3) ...
- DON'T use the hoist in unacceptable physical condition, treatment of serious illness, under alcoholic drinks effects, or under stress or mental overload condition.
- DON'T use the machine with other parts than those originals from the manufacturer.
- DON'T work without the necessary personal protection gear. These safety devices will vary upon different conditions, therefore, a qualified person in the requirement of safety and health must evaluate the working conditions and mode of use before starting works.
- DON'T access the elevator with inappropriate clothing, hanging chains, rings or loose long hairs.
- DON'T put raised brackets on the cage floor. If travelling, user's feet must be on the cage floor.
- DON'T use the hoist if the key switch has been forgotten in the lock and can be manipulated.
- DON'T dismantle integrated equipment whose maintenance is only allowed authorized personnel (i.e.: electrical motor, brake, gear-reductor).
- DON'T manipulate electrical system without express permission of the manufacturer.
- DON'T use the hoist without a differential switch on the main power supply connection line.
- DON'T use the machine with personnel traveling in the basket in MANUAL mode, except in the case of maintenance tasks and by authorized personnel.
- Do not use the machine under insufficient lighting conditions. If necessary, local lighting will be installed at access points, illuminating the hoist way. You will also install local lighting in the control panel area, which allows the correct vision of the elevator controls as needed, using the auxiliary power outlet available in the upper part of the panel.

4. SAFETY DEVICE. PARACHUTE FPC-500

4.1. Introduction

According to the specifications of Directive 2006/42/EC, the hoist must have a safety device for mechanical locking to act if the speed exceeds a set value. The parachute safety system is a mechanical unit designed to prevent accidental loss of the machine. The system only operates during the fall, when the speed exceeds a predetermined value, acting as a hoist speed tracker, not making any effort on lifting device, during normal operation of the machine.

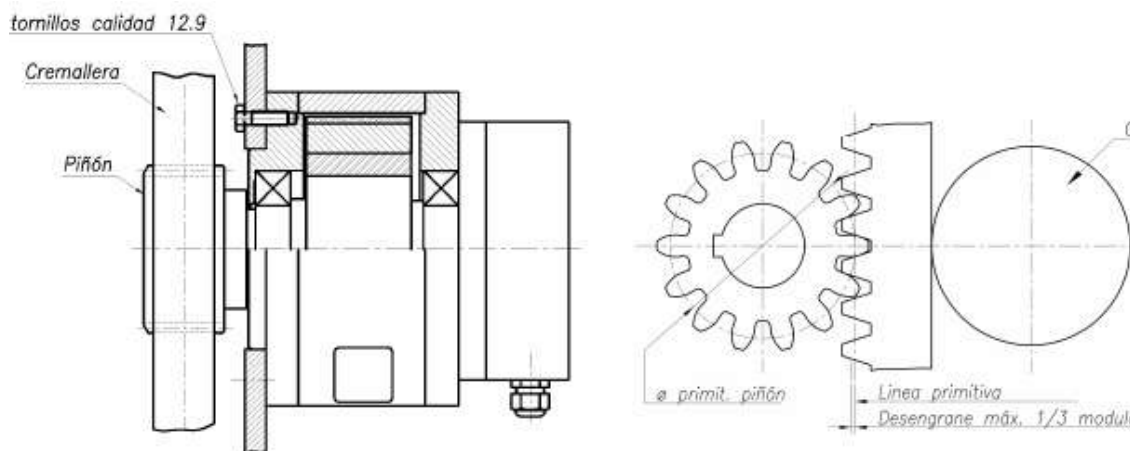

ASSEMBLY OF PARACHUTE. GENERAL DESIGN

4.2. Features:

A parachute works by blocking the drop in the case of there is a speed rising over the nominal value. The overspeed detection system is based on the principle of action of the centrifugal force to engage driven pinion into the elevator structure. On the elevators there are two intermediate crowns as parachute pinion and rack transmission. Its main components are as follows:

- **Cover:**

The parachute has waterproof housing that allows confining the security unit, preventing it from dust and corrosive atmosphere inside. It must also prevent unauthorized adjustment, so that screws should not be handled by unauthorized persons.

- **Buffer:**

The parachute has a progressive braking system so that locking is produced in a buffered way, so that after a controlled braking, the cage is stopped, according to deceleration specifications of reference standards to avoid accidents resulting from major efforts generated by moving mass inertia.

- **Locking:**

The device features a brake consisting of four sectors, which are charged up to torque referred to the elevator, so that deceleration is controlled accurately, even in case of free drop of the machine, according to the specifications of harmonized standards reference.

- **Integrated microswitch:**

The parachute includes a microswitch that is activated in case of brake locking, allowing the signal to cut the movement of hoist and preventing further operations of the machine, until the action of a person designated to release the hoist.

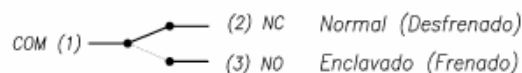
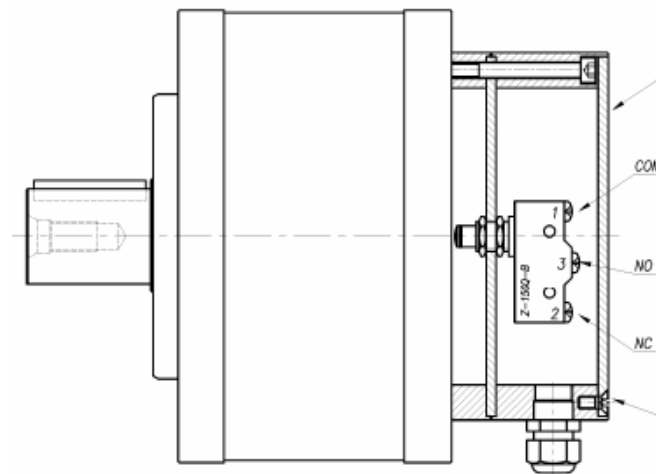

SAFETY SWITCH AND INTERNAL CONNECTION

• ID plate and features of the device:

The parachute is equipped with an identification plate, with CE logo stamped and brake characteristics:

- Brake type, mounting position and lock sense.
- Locking speed (r.p.m.) and brake torque (N·m)
- Number, date and reference of manufacture.



ID PLATE EXAMPLE ON THE PARACHUTE

4.3. Installing the parachute

The unit shall be firmly fixed to the chassis of the cage, so that the pinion is centred with the hole, to rotate at the speed of normal movement of the elevator. The unit must be fitted to the hoist with all screws and safety washers.

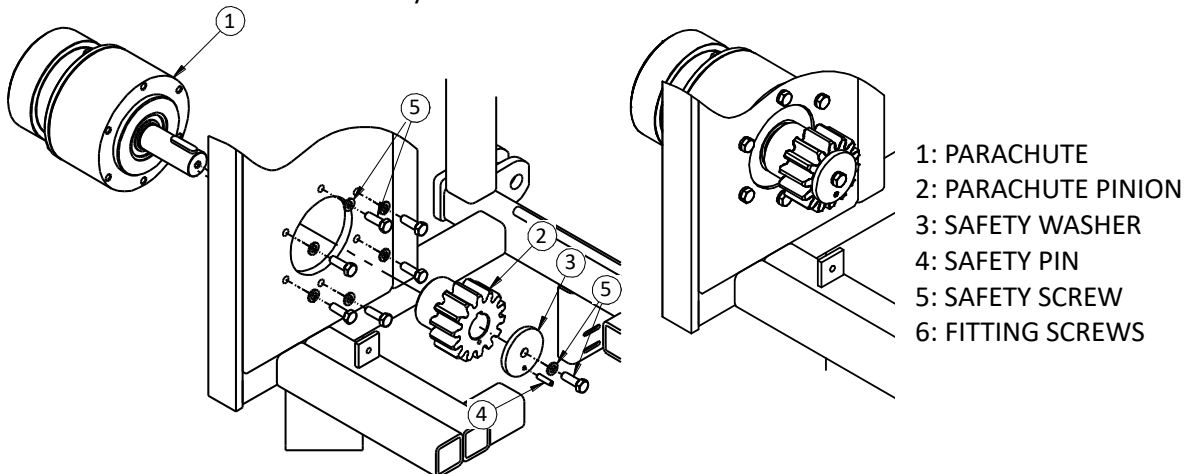

INSTALLING SAFETY UNIT IN TO THE HOIST



WARNING:
DON'T INSTALL A PARACHUTE IN A HOIST WITH OTHER FEATURES THAN THOSE MARKED IN THE PLATE



WARNING:
HANDLING AND TESTING OF THE PARACHUTE ONLY IS ONLY ALLOWED TO THE MANUFACTURER OR AUTHORIZED SERVICE PERSONNEL.

Finally, install the safety switch wire on its correct position, according to the scheme, to avoid further movement of the hoist if the safety device locks, until the actuation of technical personnel.

Once the assembly of the unit is finished, install back cover, so the device remains watertight and mechanical characteristics of the parachute are preserved along the time. Nobody but the manufacturer is allowed to manipulate screws of the unit itself.

4.4. Parachute testing.

In accordance with the reference harmonized standard, tests on the parachute must be performed, to verify its functioning properly.

A) MANUFACTURER TEST

ALBA performs a test on each lift during the machine assembly to ensure the safety and proper functioning of the device. The test result is reflected in the TEST CERTIFICATE, which accompanies this manual of the machine.

B) USER TEST

Periodically, **every 4 months**, or **after each assembly machine on site**, a functional test of the parachute shall be performed, in accordance with the instructions set out below. The test of the parachute must be further supplemented with a brake inspection, checking the correct appearance of all the elements and the sealing of the outer cover. This process is repeated more often if the machine operates in extreme environmental conditions.

PARACHUTE TEST PROCEDURE



WARNING: (PT-1V)

FOR SAFETY PURPOSE, RELAY HEAD "RDP" IS NOT MOUNTED. INSTALL IT BEFORE TEST, THAT WAY TEST BOARD WORKS. AFTER TEST, REMOVE "RDP"

- 1.- The area under the machine must be free of people and obstacles.
- 2.- The hoist shall be securely fastened to the facade or structure.
- 3.- Remove the parachute bridge on the mainboard and connect the pendant control.
- 4.- Leave the hoist and put into the cage **MAXIMUM** load and take position at safe distance.
- 5.- Raise the hoist with pendant control and stop it at approx. 3 m above the ground.
- 6.- Turn on the left "TEST" key and let the hoist drop until parachute activates and cage stop. Check if elevator stops after a little slip, and then it's blocked for further descent movements.

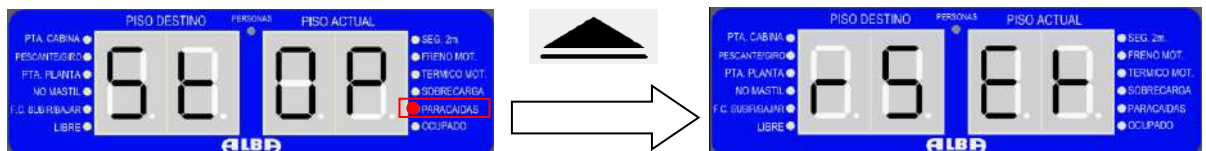

- 7.- To release the parachute, it's necessary to press "UP" for a while, until display shows RESET. Then hoist can be recovered and must be descended to reference point. After pressing "KEY" button to reset, the hoist is released and can be commissioning again.



IMPORTANT:

TEST THE PARACHUTE PERIODICALLY AND WRITE THE RESULT IN THE OPERATOR'S MANUAL REGISTRATION.

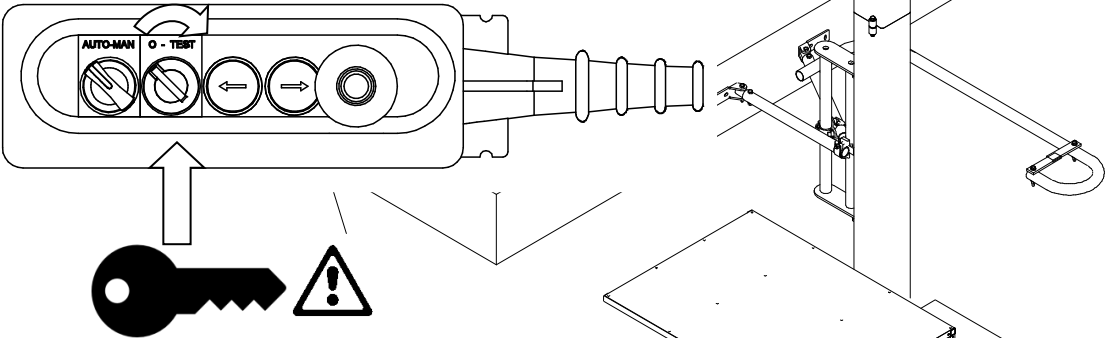

**ATTENTION:
HAZARDOUS OPERATION!**

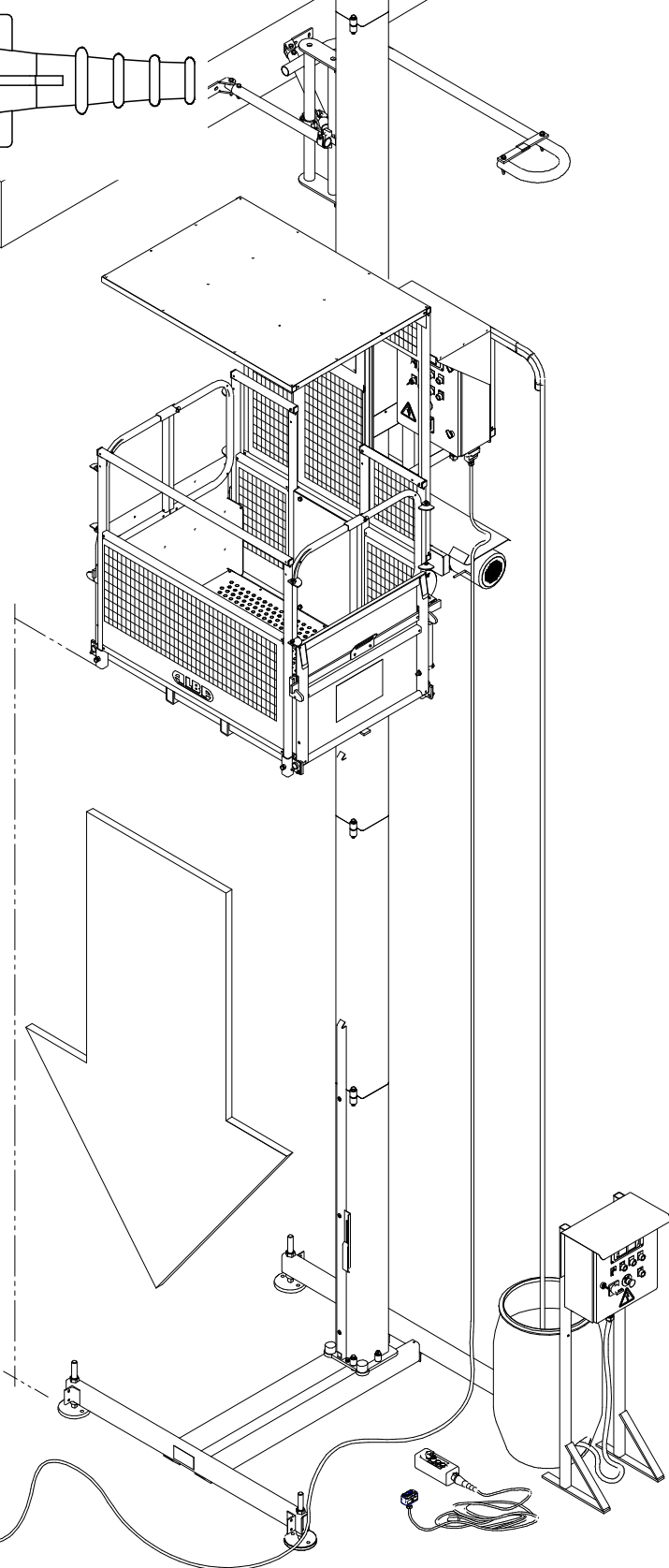
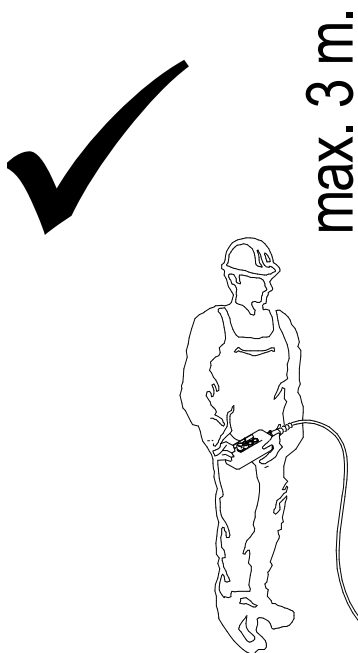

PARACHUTE TEST PROCEDURE

4.5 Actions to take if safety device is activated.

The parachute is activated in case that the emergency lowering speed exceeds normal download speed of the hoist. This can only happen in the following cases:

- A) Case of power failure or electrical malfunction, and it is necessary to descent the hoist manually, using the manual lever to release the brake of motor, and this procedure is performed without considering the information in this manual operator, exceeding the speed of the parachute limit.
- B) Case of accident or structural failure that causes gear pinion disengage or gearmotor shaft breaking or any of its elements.
- C) Case of parachute testing.

Case of scenario A or C, the person who performs emergency descent will be a qualified technician who is trained to release device and reset the hoist. This requires connecting the keypad to test and reset parachute.



**ATTENTION:
MOTOR BRAKE MANUAL RELEASE ONLY IS ALLOWED TO TECHNICAL PERSONNEL AUTHORIZED TO TRAVEL ON THE ROOF OF THE CAGE.**

In case of occurrence of case (B) shall cease machine operation until the action of an authorized technician which chooses the best option depending on the severity of problem. If there is no clear solution, perform the disassembly of the machinery with auxiliary means.

4.6. Replacement of parachute

Following the instructions of the safety device manufacturer, to ensure integrity of the device, along the time, parachute shall be replaced after **6 YEARS** from the date of installation on the hoist. See installation plate.

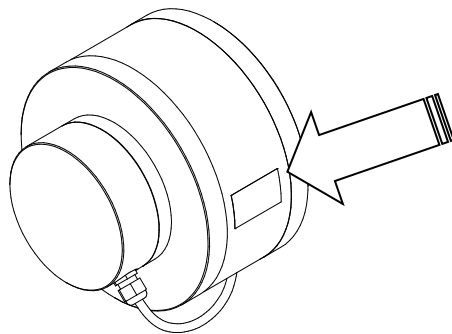

Fecha de instalación:	Installation date:	01 -2025
Date de installation:		
Fecha de sustitución:	Replacement date:	01 -2031
Date de replacement:		

INSTALLATION AND REPLACEMENT PLATE

· For more information: <https://www.eide.net/en/productos/fpc-overspeed-safety-brake/>



**IMPORTANT:
AFTER REPLACEMENT OF THE PARACHUTE, DROP TEST OF THE NEW DEVICE MUST BE PERFORMED. WRITE THE RESULT IN THE USER'S MANUAL LOG.**

5. MAINTENANCE OF THE MACHINE.



WARNING:
BEFORE PERFORMING ANY MAINTENANCE ACTION, TURN THE POWER OFF AND IF REQUIRED, BLOCK VERTICAL MOVEMENT AT LEAST 1.8 m. HEIGHT UNDER THE CAGE. MAINTENANCE TASKS MUST BE PERFORMED WITHOUT LOADS.

5.3. DAILY Maintenance.

Daily maintenance includes basic operations of visual inspection in the hoist, performed by the person responsible of the hoist on the building. Every day, prior to use, visual inspection of the elevator should be done, according to the following service points:

- There's no accumulation of ice, snow or debris inside the cage, or near the hoist.
- There's no excessive wear in the rack, or in the vertical pipe of the mast.
- All the cage protections are installed, and there's no dangerous holes or gaps.
- Identification and characteristics plate is installed inside the cage.
- Zone below hoist is bounded and base fence is installed.
- There isn't any warped or cracked part (Case of, change it).
- Electrical wires are correctly installed and tightly guided on the hoist.
- Guide rollers are in touch with mast tube and without excessive wear.
- There are no power lines near the hoist that endanger people or machine.
- There are no outgoing elements in the facade that may interfere with the machine.
- Electrical safety devices are operational (doors, end track switch, mast sensor).
- Emergency stop works properly.
- Facade anchorages are correctly installed.
- Cage door, fence door and landing door auto-lock system work properly.
- Cage floor and walls are in good condition.
- Rack-pinion transmission is correctly engaged.
- Control and power boards are in good condition
- Cage lamp lights properly.
- All the controls, panels and indicators work properly.
- Cable travels and slides over the cable holder properly.

After reviewing all the checkpoints listed, and solved any problem, the machine can be used safely.

5.2. Periodic maintenance schedule





WARNING:

IN CASE OF ELECTRICAL MALFUNCTION IN THE HOIST, DO NOT HANDLE ELECTRICAL EQUIPMENT. MAINTENANCE AND INSPECTION OF THE HOIST ONLY MUST BE PERFORMED BY AUTHORIZED PERSONNEL.

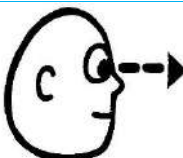

Maintenance of the lift must be performed by the staff responsible for the machine and the results must be recorded on the MAINTENANCE RECORD.

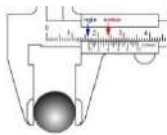
MAINTENANCE TASKS SCHEDULE

OPERATION	ELEMENT	TOOL	PERIODICITY
1 	<ul style="list-style-type: none"> FIXING BOLTS CAGE-CHASSIS (CHECKING). ENDTRACK CAMS. MAST SENSOR (CHECK GAP: ± 5 mm.). MOTORGEAR OIL LEVEL. DOOR MICROSWITCH. LOAD CELL (CHECK FUNTION) SWITCHBOARD LIGHTS ANS BUTTONS. MAST PIPE (WEAR OR WELDING FAILURE). GUIDE ROLLERS RETAINING RINGS. MOTOR BRAKE RECTIFIER (CHECK FUNCTION) COMMUNICATION CABLE (INSPECTION) ANCHORAGE (CHECK INTERFERENCE OR LOOSENING) BASE BUFFERS (INSPECTION) 	-	40 h WORK (ONCE A MONTH)
2 	<ul style="list-style-type: none"> MAST RACK GEARMOTOR PINION. PARACHUTE PINION. 	LITHIC GREASE	40 h WORK (ONCE A MONTH)
3 	<ul style="list-style-type: none"> MAST SCREWS. GUIDE ROLLERS SCREWS. BASEFRAME TO GROUND SCREWS. ANCHOR TO SUPPORTING STRUCTURE SCREWS 	SPANNER	QUARTERLY (4 TIMES/YEAR)
4 	<ul style="list-style-type: none"> ROLLER GUIDE DIMENSION CHECKING MAST RACK DIMENSION CHECKING GEARMOTOR PINION CHECKINGS BRAKE MOTOR CHECKING 	CALIBER CALIBER MICROMETER GAUGES	ANNUAL (OR AFTER DISMANTLIING)
5 GENERAL REV. (AFTER DISMANTLING OR PROLONGED NON-USE PERIOD))	<ol style="list-style-type: none"> DEFORMATION OR DAMAGE ON MASTS, ANCHOR, DOORS, HANDRAILS, FLOOR... GEARMOTOR AND BRAKE INSPECTION (Rectifier, Voltage & Coil resistance) 		

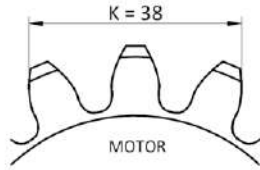
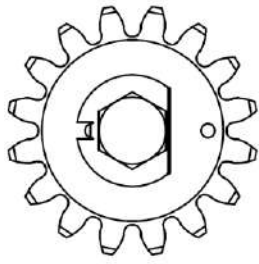
MAINTENANCE CHECKING TABLE

CONTROL DIMENSION K [mm/in]

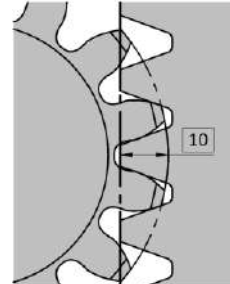
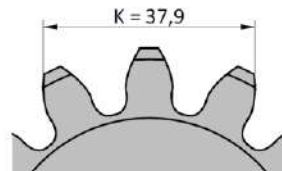
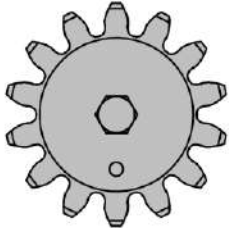
	Nom.	Min.
PINION Z16	38	35
PINION Z14	37,9	35

OVERLAP □ [mm]

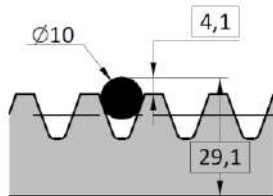
	Nom.	Min.
□	10	8,3

CONTROL DIMENSION □ [mm]

	Nom.	Min.
□ A	4,1	3
□ B	29,1	28

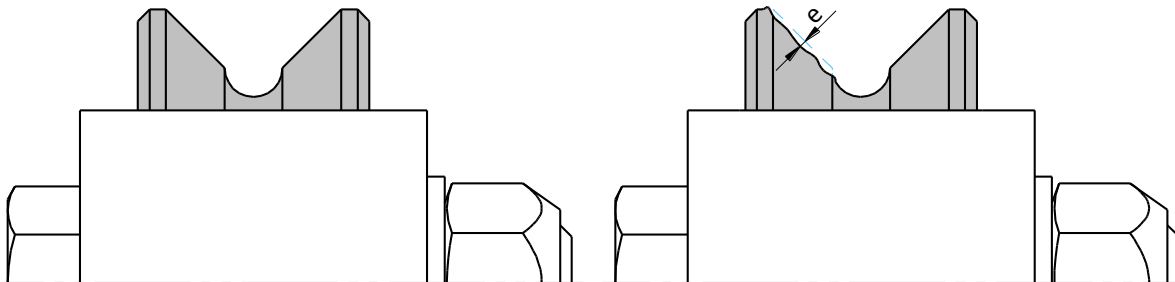
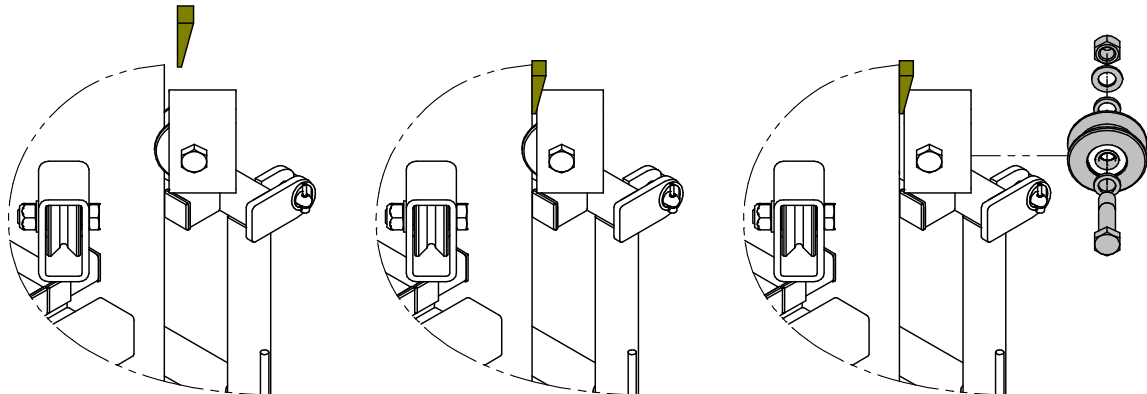
CHECKING RACK AND PINION WEAR

MAST GUIDE ROLLERS COMPROBATION

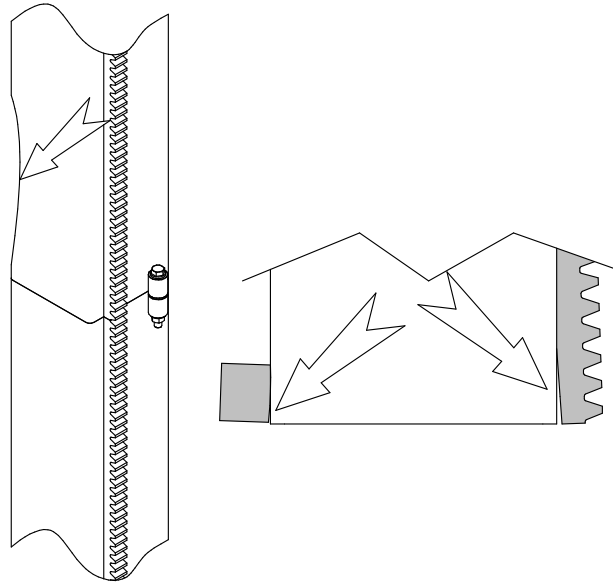
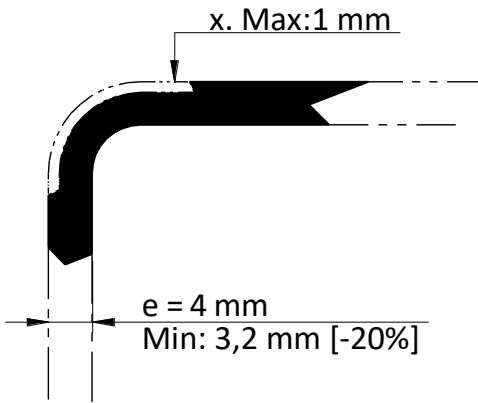
ROLLERS SUBSTITUTION

ATENCIÓN:
ENSURE ROLLER'S WEAR IS UNIFORM ALONG THE CONTACT'S CIRCUNFERENCE



CHECKING MAST WEAR AND DAMAGE



ATTENTION:
CHECK FOR POSSIBLE DAMAGES AND EXCESSIVE WEAR ON MASTS BEFORE AND AFTER ERECTION TAKEN INTO ACCOUNT PERIODICITY INDICATED

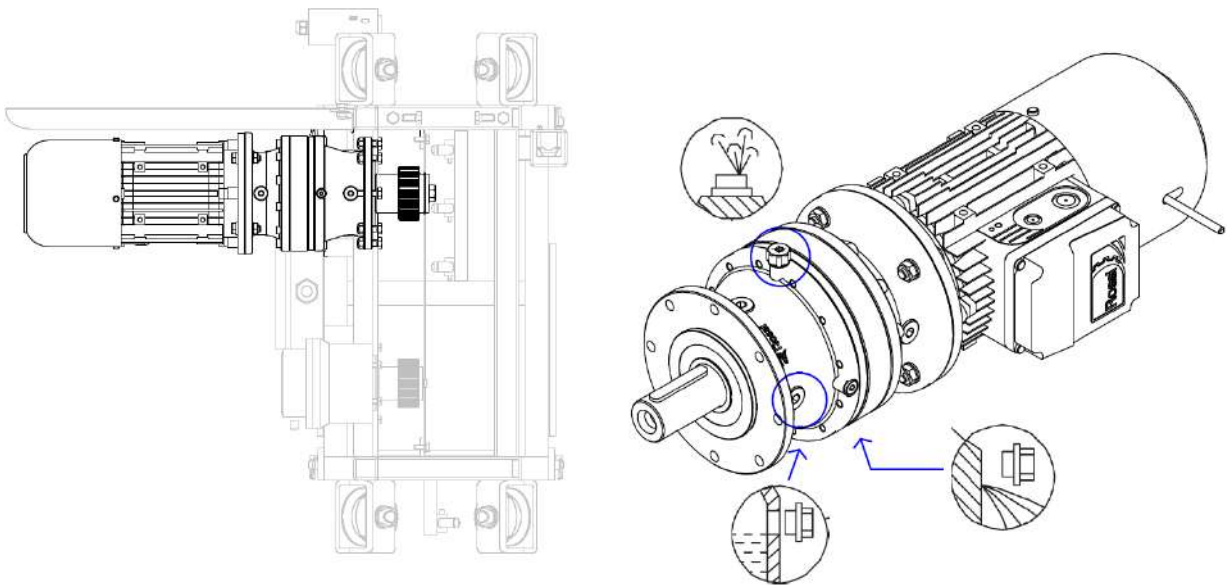

Properties			Method	Shell Omala S4 GXV 220
Kinematic Viscosity	@40°C	mm ² /s	ASTM D445	220
Kinematic Viscosity	@100°C	mm ² /s	ASTM D445	30
Viscosity Index			ASTM D2270	171
Flash Point (COC)		°C minimum	ASTM D92	240
Pour Point		°C	ASTM D97	-42
Density	@15°C	kg/m ³	ASTM D4052	864
Four Ball EP Weld load		kg minimum	ASTM D2783	250
FZG Load Carrying Test		failure load stage minimum	A/8,3/90	14

MOTOR GEAR MAINTENENACE



IMPORTANT:
MOTOR GEARS ARE INSTALLED FILLED OF 220 SYTHETIC OIL FOR ITS LIFE-TIME LUBRICATION, IN ABSENCE OF EXTERIOR CONTAMINATION. REPLACE THE OIL IF NECESSARY. REPLACE WITH OIL ACCORDING TO THE GRADE INDICATED.



IMPORTANT:
MOTORGEAR OIL IS GOOD TO USE IN RANGE $0^{\circ}\text{C} < T^{\text{a}} < 40^{\circ}\text{C}$ WITH PEAKS $-20^{\circ}\text{C} < T^{\text{a}} < 50^{\circ}\text{C}$. REPLACE OIL COMPLETELY. DO NOT MIX DIFFERENT OILS.

AUTOMATIC GREASING SYSTEM (OPT)



AUTOMATIC GREASING CENTER

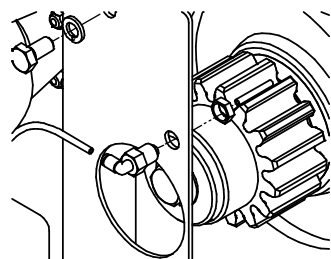

PINION GREASING POINTS POSITION

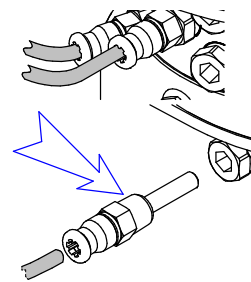
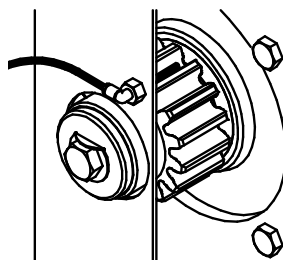

GREASING FLOW DISTRIBUTOR

GREASING SYSTEM TECHNICAL FEATURES

Grease TYPE	Lithium grease	
Types of grease allowed:	NLGI	ASTM
Very soft	0	355 – 385
Medium soft	1	310 – 340
Medium (Recommended)	2	265 - 295
Tank capacity:	0,5 l.	
Lubrication speed:	2x12 gr/h.	
Tank life:	~ 70 h. (Hoist working)	



CONTROL LOCKED (PRESS ↑↓ TO UNLOCK)

YELLOW – GREASING PUMP WORKING

RED – GREASING MOTOR BLOCKED

RED – MIN. GREASE TANK LEVEL

RED – VOLTAGE UNDER MIN. LEVEL

CANCEL ALARM / GREASING EXTRA CYCLE

**INCREASE OR REDUCE GREASING FREQ. /CYCLE.
SIMULTANEUNS PRESS. – LOCK CONTROL**

GREASING UNIT CONTROL CONSOLE

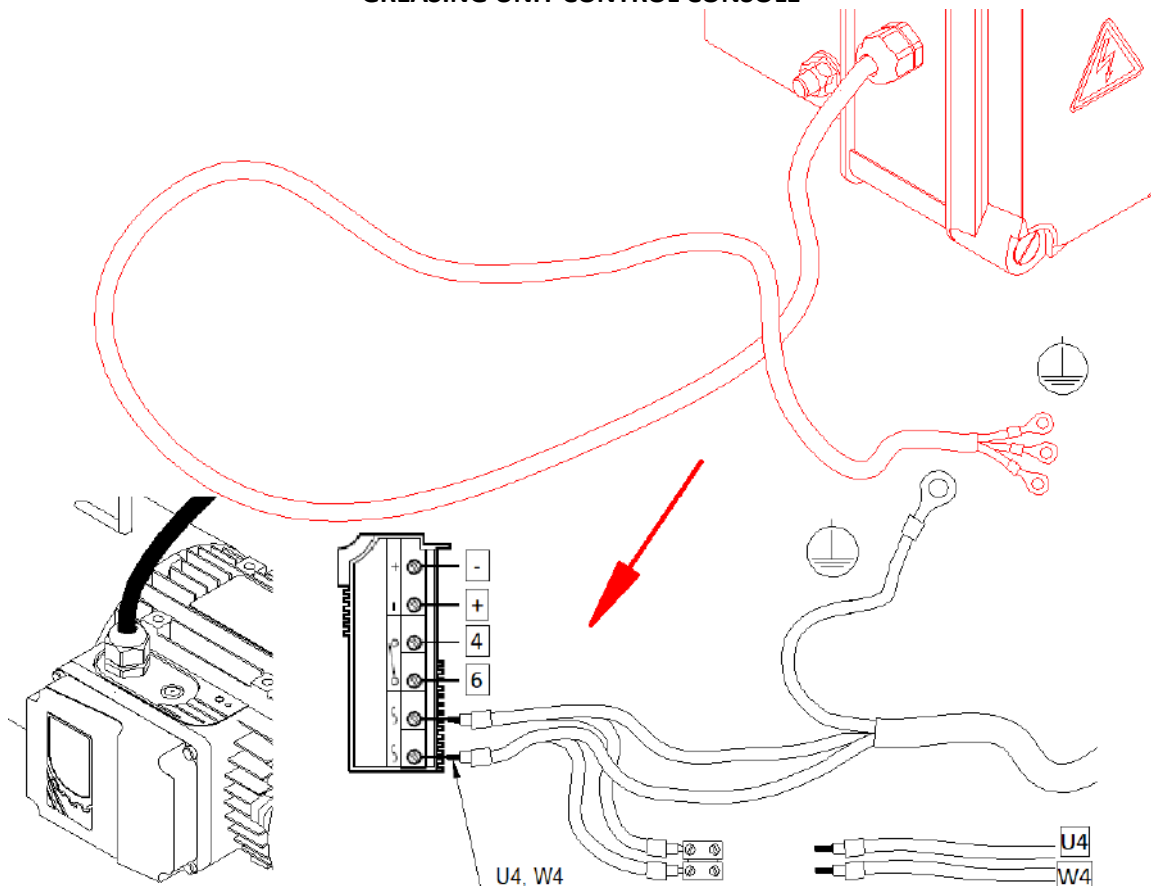

ELECTRIC CONNECTION OF GREASIG SYSTEM (PT -2V)

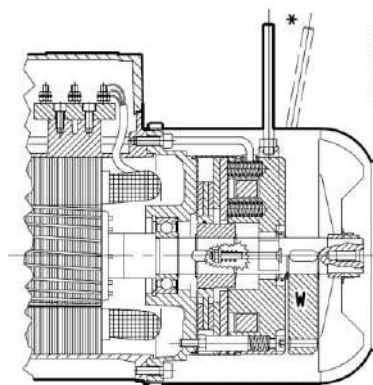
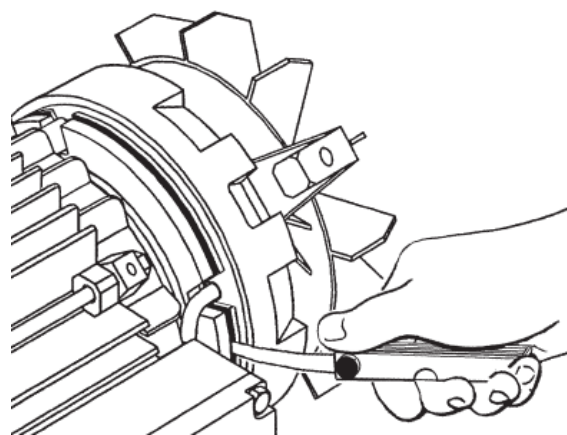
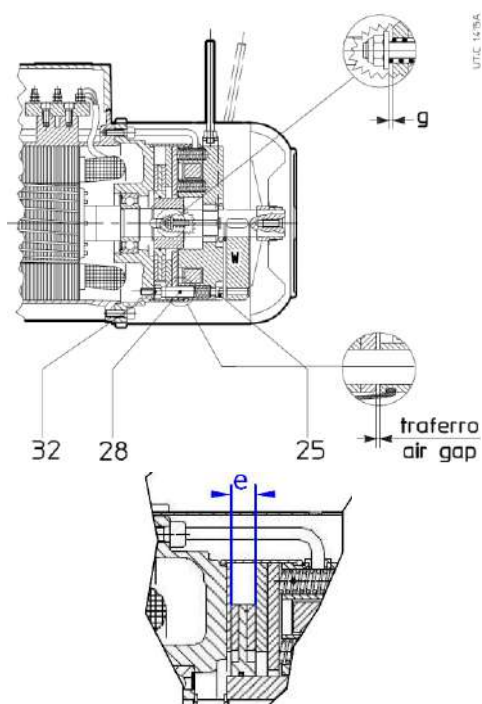
INSTRUCTION FOR MAINTENANCE OF ELECTRIC MOTOR-BRAKE

MOTOR BRAKE WITH D.C. BRAKE AND MANUAL RELEASE LEVER

CONTROL MEASURES mm/[inch]

	Nom.	Max.	Min.
Air gap	0,3	0,45	-
Brake disc thick.(e)	-	-	7
Lever play (g)	0,6	-	-

BRAKE DISC ADJUSTMENT

IMPORTANT:

AIR GAP HIGHER THAN THE MAXIMUM VALUE MAY AFFECT BRAKE TORQUE. CHECK PERIODICALLY AIR GAP AND BRAKE DISC THICKNESS.

BRAKE ADJUSTMENT PROCEDURE:

1. Unlock nuts **No.32**, located on 3 positions spaced 120°
2. Tight fixation bolts **No.25** [in case of flywheel, act through the available holes] up to reach the minimum airgap measured in 3 positions spaced 120° with feeler gauges, as close as possible to guides **No.28**.
3. Tight nuts **No.32** keeping same position of fixation bolts **No.25**.
4. Check final airgap and compare with values indicated on table.

IMPORTANT:

AFTER SEVERAL AIR GAP ADJUSTMENTS, VERIFY THE BRAKE THICKNESS (e) IS NOT LOWER THAN MINIMUM INDICATED ON TABLE. REPLACE IF NECESSARY

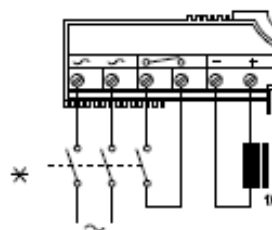
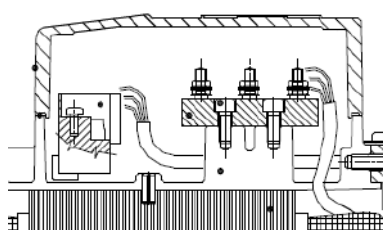

BRAKE'S D.C. SUPPLY RECTIFIER

RECTIFIER CHECK TABLE

a) Vac power supply	(~ . ~)	200-460 Vac
b) Vdc power output	(- . +)	75 – 105 Vdc
c) Coil resistance (*)	(- . +)	±250 Ω

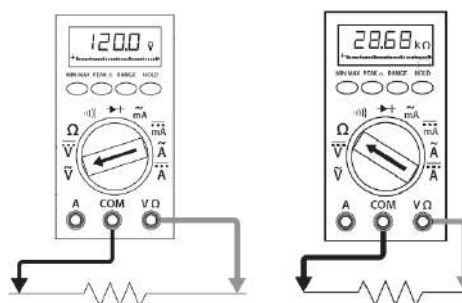
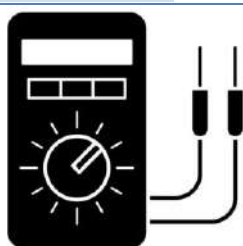

a) ~.~ ; b) - . +

c) Ω

RECTIFIER CHECKING



IMPORTANT:
CHECK POWER INPUT/OUTPUT WITH HOISTS UNDER MOVEMENTS TO ENSURE RECTIFIER FUNCTIONS. ATTENTION! ELECTRIC RISK.



IMPORTANT (*):
TO CHECK BRAKE COIL CONDITION, REMOVE SUPPLY CABLES FROM RECTIFIER (+, -) AND CHECK RESISTANCE READING ACCORDING TO PROCEDURE c). REPLACE IF NECESSARY.



IMPORTANT:
AFTER BRAKE ADJUSTMENT, CHECK RELEASE IF LEVER BAKCLASH (g) ALLOWS MANUAL BRAKE RELEASING PROPERLY. IF NECESSARY, AMEND (g) VALUE ACCORDING TO TABLE ABOVE.

a company of the Habasit group www.rossi-group.com		IEC 60334-1		 IE1 made in Italy	
MOT. 3~ N	06202/11 01/11	IP 55	AMB. 40°C	IC 411	
HBZ 80B4	B5	kg 9.2	I.CL. F S 1 CONT.		
Frano Brake	Nm	V~/ Hz	A	#/###	V=
BZ04	15	110+480/50+60	0,11	RM1	103
Esecuzione Execution					
Δ V Y	Hz	A	kW	min ⁻¹	cos φ
230 / 400	50	3.3 / 1.9	0.75	1400	0,72
265 / 460	60	3.3 / 1.9	0.75 SF1.15	1690	0,68
50Hz IE1 74,7(100%) 74,2(75%) 70,5(50%)					
60Hz NEMA NOM.EFF. 78,5% 1HP DES.C CODE K					

MOTOR PLATE EXAMPLE TO SPARE PART REQUESTING

GEARMOTOR – ELECTRIC MOTOR SUBSTITUTION

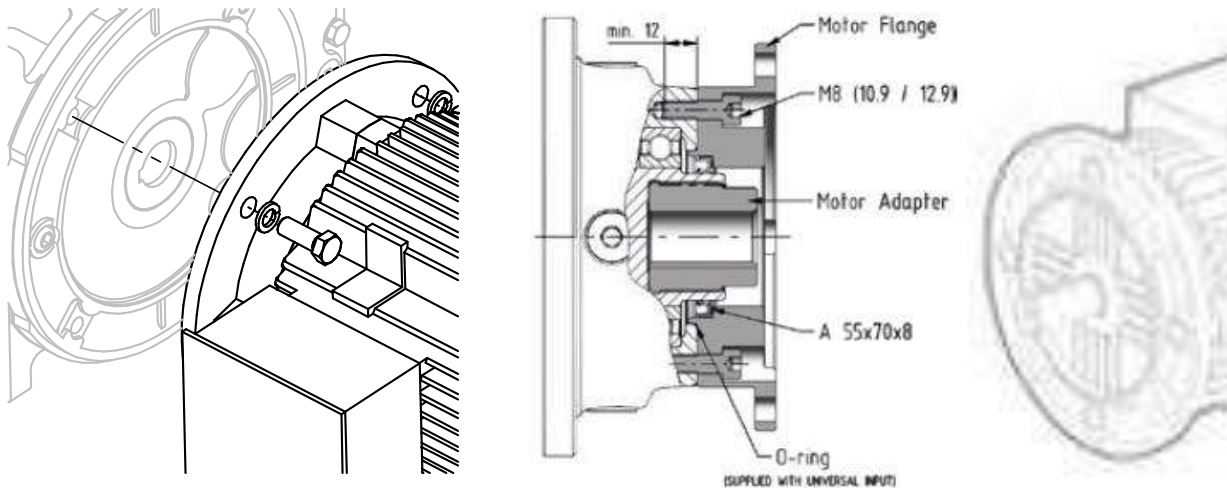

1. Clean motor and gearbox surfaces to fit thoroughly.
2. Mount the parallel key on the motor axel and perform coupling to gearbox hole carefully.
1. Fit the motor flange to gearbox flange with screws and nuts.

PREVENTIVE MAINTENANCE OF MOTOR AND ELECTRIC BRAKE:

- Keep external surfaces free from oil, dust and machining residuals.
- Keep free all air cooling circuits (housing, air input).
- Check that electric connections are fitted properly.
- Check the correct tightness of the motor and see that there are no leaks in the seals.
- Check that motor run is free from vibrations and anomalous noises.

**ATTENTION:**

TO ORDER SPARE PARTS FOR THE MOTOR OR ELECTRIC BRAKE, IT IS NECESSARY TO REFER TO THE MOTOR PLATE INFORMATION. THAT WAY, SPARE PART SUPPLY ERRORS ARE AVOIDED.

**INFORMATION:**

IF YOU REQUIRE TECHNICAL ASSISTANCE FOR GEARMOTOR, YOU CAN CONTACT THE MANUFACTURER, OR THE SERVICE MOTOR MANUFACTURER IN EACH COUNTRY. SEE CONTACT POINTS: <http://www.rossi-group.com>

**ATTENTION:**

CHECK IF HOIST IS CONNECTED TO A POWER SUPPLY EQUIPED WITH DIFFERENTIAL PROTECTION 300mA.

5.3. Instructions for troubleshooting.**GEARMOTOR**

Problem	Probable cause	Solution
Motor doesn't work.	Supply line fault. Motor box connection fault. Brake doesn't work. Motor internal fault.	Check 3-phase electric supply. Check motor connection. Check brake s/section. 5.2 Ask to the manufacturer.
Motor can't raise rated load.	Motor connection problem Insufficient voltage supply Supply voltage drop.	Check motor connection. Check supply line. Check supply cross section wire.
Motor overheats.	Motor connection error. Motor locked. Voltage supply error. Fan cover obstructed. Insufficient ventilation air flow. Brake doesn't work.	Check motor connection. Check brake s/section. 5.2 Check supply line. Release air passage to the fan. Check for obstacles to ventilation. Check brake s/section. 5.2
Excessive current consumption.	Brake locked. Motor coil damage.	Check brake s/section. 5.2 Ask to the manufacturer.
Motor brake doesn't release .	Brake connection fault. Rectifier damaged. Excessive brake airgap. Brake coil damaged.	Check motor connections. Check rectifier s/section. 5.2 Check air-gap s/section. 5.2 Check brake coil s/section. 5.2
Brake doesn't hold the load.	Excessive brake airgap. Brake coil damaged. Excessive brake disk wear.	Check brake coil s/section. 5.2 Ask to the manufacturer . Replace brake disk
Excessive brake noise.	Excessive airgap.	Check air-gap s/section. 5.2
GENERAL		
Hoist doesn't run. (OUT OF SERVICE RED LIGHT ON)	There's safety device activated. Frequency converter error. E1 fault. Phase error.	Check emergencies stop buttons (SE), or safety end track microswitches FCSG. Check frequency converter status. Check electric diagram. Rearm E1. Change supply phase connection.
Hoist moves doing abnormal noise or it doesn't smoothly.	Guide roller damaged. Lack of grease in pinion. Lack of grease in rack	Check and change guide rollers. Check bearings and change if required. Apply grease in pinion and rack.
Hoist slides down when charging loads.	Problem or brake wear. Overload on the cage.	Check brake coil s/section. 5.2 Remove overload.
Hoist doesn't stop in upper/lower limits, or at landing doors.	Problem with magnetic sensor. Problem with end track limit switches.	Check encoder and magnetic ring. Check end track limit switches.
Hoist doesn't stops on 2 m point.	Problem with 2 m. switch or cam.	Check 2 m. end track switch and cam.
E3 or E4 fault.	Problem in control transformer.	Check / Replace transformer.
E2 fault.	Hand tool socket excessive consumption.	Check hand tools socket connection.
E5 fault.	Brake supply rectifier fault.	Check rectifier s/section. 5.2
Hoist stops suddenly.	Overload. Power supply failure. Door open.	Check load on the cage. Check electrical connection. Check landing doors and cage doors.
Cage of the hoist vibrates abnormal.	Non tightened screws. Rack or pinion wear problem. Lack of lubrication. Mast tube tubes wear problem.	Check guide roller s/section. 5.2 Check rack and pinion gear. Lubricate rack and pinion. Check mast for tube wear.
Gearmotor sounds abnormally.	Lack of oil on the motor box. Gearbox bearing failure.	Check oil level and oil leaks. Ask to the manufacturer.
Hoist suffer stops when moving.	Communication cable damaged. End track or door switches unadjusted.	Check communication cable. Check end track limit switches position.
Hoist can't raise rated load.	Cross section wires inadequate. Motor brake damaged. Supply voltage inadequate.	Check supply wire. Check brake s/section. 5.2 Check voltage supply
Hoist doesn't move up or down.	LED panel indication Cage or landing door incorrectly closed	Check indications. Check cage / landing doors.

5.4. Maintenance record.

According to the procedure specified in the user's manual, the responsible for maintenance of the hoist should fill this table according to the frequency indicated, for the record of scheduled tasks.

No.	DATE	TASK DESCRIPTION	NAME	SIGNATURE
1				
2				
3				
4				
5				
6				
7				
8				
9				
10				
11				
12				
13				
14				
15				
16				
17				
18				
19				
20				
21				
22				
23				
24				
25				
26				
27				
28				
29				
30				
31				
32				
33				
34				
35				
36				
37				
38				
39				
40				
41				
42				
43				
44				
45				
No.	DATE	TASK DESCRIPTION	NAME	SIGNATURE
46				

47	
48	
49	
50	
51	
52	
53	
54	
55	
56	
57	
58	
59	
60	
61	
62	
63	
64	
65	
66	
67	
68	
69	
70	
71	
72	
73	
74	
75	
76	
77	
78	
79	
80	
81	
82	
83	
84	
85	
86	
87	
88	
89	
90	
91	
92	
93	
94	
95	

5.5. Trouble record

TYPE OF FAILURE:

Cause:

Reparations performed:

.....

.....

		PARTS TO CHANGE			
Code	Denomination	Quantity	Code	Denomination	Quantity

ALBA authorized technical person

User

.....

.....

Place

Date.....

TYPE OF FAILURE:

Cause:

Reparations performed:

.....

.....

		PARTS TO CHANGE			
Code	Denomination	Quantity	Code	Denomination	Quantity

ALBA authorized technical person

User

.....

.....

Place

Date.....

TYPE OF FAILURE:

Cause:

Reparations performed:

.....

.....

PARTS TO CHANGE					
Code	Denomination	Quantity	Code	Denomination	Quantity

ALBA authorized technical person User

.....

Place Date.....

TYPE OF FAILURE:

Cause:

Reparations performed:

.....

.....

PARTS TO CHANGE					
Code	Denomination	Quantity	Code	Denomination	Quantity

ALBA authorized technical person User

.....

Place Date.....

TYPE OF FAILURE:

Cause:

Reparations performed:

.....

.....

PARTS TO CHANGE					
Code	Denomination	Quantity	Code	Denomination	Quantity

ALBA authorized technical person

User

.....

Place Date.....

TYPE OF FAILURE:

Cause:

Reparations performed:

.....

.....

PARTS TO CHANGE					
Code	Denomination	Quantity	Code	Denomination	Quantity

ALBA authorised technical person

User

.....

Place Date.....

TYPE OF FAILURE:

Cause:

Reparations performed:

.....

.....

		PARTS TO CHANGE			
Code	Denomination	Quantity	Code	Denomination	Quantity

ALBA authorized technical person

User

.....

Place Date.....

TYPE OF FAILURE:

Cause:

Reparations performed:

.....

.....

		PARTS TO CHANGE			
Code	Denomination	Quantity	Code	Denomination	Quantity

ALBA authorized technical person

User

.....

Place Date.....